

POSTERS

Theme: Clinical Trials Methodology

P21: PATTERNS OF MMSE SUBTEST SCORES IN AMYLOID-POSITIVE AND -NEGATIVE PARTICIPANTS IN J-ADNI. Ryoko Ihara¹, Kazushi Suzuki¹, Atsushi Iwata², Takeshi Iwatsubo^{1,3}, the Japanese Alzheimer's Disease Neuroimaging Initiative ((1) *The Unit for Early and Exploratory Clinical Development, The University of Tokyo Hospital, Tokyo - Japan*; (2) *Department of Neurology, The University of Tokyo, Tokyo - Japan*; (3) *Department of Neuropathology, The University of Tokyo, Tokyo - Japan*)

Backgrounds: The MMSE is commonly used both in clinical research and in clinical practice. As the MMSE is composed of subtests for multiple cognitive domains, namely, orientation, memory, attention, language and visuospatial function; thus, it tells more than the total score which briefly indicates the severity of cognitive impairment. **Objectives:** Therefore, we analyzed the Japanese Alzheimer's Disease Neuroimaging Initiative (J-ADNI) data to clarify how subscores of the MMSE differ between participants with or without Alzheimer's pathology. **Methods:** 154 cognitively normal participants, 234 with mild cognitive impairment (MCI) and 149 with Alzheimer's disease (AD) were enrolled in the J-ADNI and underwent 3-year follow-up with intensive assessments. The dataset of the J-ADNI was obtained from the National Bioscience Database Center (Tokyo, Japan) under approval. 175 and 114 participants were defined as amyloid positive (Ab+) and negative (Ab-), respectively, based on 11C-PiB or 11C-BF-227 PET and/or cerebrospinal fluid Ab1-42. Total 1,332 MMSE tests linked to amyloid status were included in this analysis (790 from Ab+ and 542 from Ab-). Hypothesized that a score of each subtest inverse sigmoidally changes from maximum score to zero as the disease progresses, sigmoidal curve approximation was adapted with MMSE total score set to X axis from 30 to zero as "assumed" disease progression and score of each subtest set to Y axis. Ab+ and Ab- groups were compared. **Results:** Because of inclusion criteria (MMSE scores 24-30 for cognitively normal and MCI, 20-26 for AD), histogram of the MMSE total score showed left-skewed distribution, and median of the total MMSE score was 29 for the Ab- group and 24 for the Ab+ group. When focusing on the early phase of the disease progression, there were noticeable differences between Ab+ and Ab- groups in the delayed recall task and the attention task. Ab+ showed a steeper decline in the delayed recall task (-0.6 per one point decrease of MMSE total score in Ab+, -0.3 in Ab-). In contrast, Ab- showed a steady decline in the attention task while Ab+ stay minimally affected until MMSE total score declines to 25. Next, we defined two patterns of scores as follows: attention predominant pattern defined as any of the following: 1) delayed recall >0 and attention <5, 2) delayed recall =3 and 3-step command <3, 3) delayed recall =3 and immediate recall <3. Memory predominant pattern is defined as delayed recall <3 and attention =5. When participants with baseline MMSE total score between 25 and 29 were selected (81 Ab+ participants, 59 Ab- participants), 75% were classified as the memory predominant pattern and 16% were classified as the attention predominant pattern among Ab+ participants, while 58% were classified as memory predominant pattern and 37% as

attention predominant pattern among Ab- participants ($p=0.02$, Chi-squared test). 63% of the participants who presented attention predominant pattern at baseline were proven not having Alzheimer's pathology. **Conclusions:** This study has some limitations. Age and the severity of the disease were different between the Ab+ and Ab- groups. Ab+ group included slightly but significantly older and significantly more severe cases. However, this study suggested if attention disturbance is seen in an individual with relatively preserved MMSE total score, pathologies other than AD, possibly including normal brain, may be considered.

P45: INNOVATIONS IN CARE COMMUNITY-BASED RECRUITMENT TO CLINICAL TRIAL RESEARCH. Jacobo Mintzer¹, Mike Splaine², Erin Beck³ ((1) *Research and Innovation Center, Roper St. Francis, Charleston, SC, USA*; Managing Partner, Recruitment Partners LLC, Columbia, MD, USA; (2) *Managing Partner, Recruitment Partners LLC, Columbia, MD, USA*; (3) *Director of Site Recruitment and Management, Recruitment Partners LLC, Columbia, MD, USA*)

Background: Approximately Research is a critical method for changing the course of impact for Alzheimer's disease (AD). Specifically, clinical trial research is needed to identify new treatments for the management, prevention, or cure of Alzheimer's disease. However, progress in identification of safe, effective and tolerable treatments has been slow and inconsistent, with a significant challenge to getting new treatments to market being the difficulty recruiting AD clinical trial populations. In fact, recruitment and retention of clinical trial populations has been deemed the "greatest obstacle" to developing Alzheimer's treatments by a 2013 Pharmaceutical Research and Manufacturers of America (PhRMA) report. There are several documented factors contributing to slow recruitment to AD trials including logistical and financial challenges, study partner requirements, attitudinal barriers, and limited access. With a growing number of clinical trials across all phases and more than 70,000 volunteers needed to participate in Alzheimer's clinical trials in the United States alone, it is critical to evaluate site-level clinical trial methodologies and opportunities for innovation. **Methods:** Recruitment Partners LLC has developed a new model of clinical trial delivery that brings research to participants, rather than bringing the participant to the research site. The goal is to create care communitybased research sites that overcome common challenges to participation. Through a standardized process, RP develops the capacity of nursing homes, assisted living facilities, and adult day centers to carry out clinical trials as "non-traditional research sites," with all study activities occurring at the care community. This innovative program bridges the gap between research and care by integrating clinical trial participation directly into the care options provided by the communities where participants live or regularly visit. Non-traditional site development includes identification of care community staff or contracted health professionals to serve as the site study team. Care communities receive specialized trainings and on-site learning and planning workshops to adapt Good Clinical Practice (GCP) to the non-traditional research setting, develop standard operating procedures (SOPs) and prepare for qualification visits. Study opportunities are presented to fit the patient population and interests of communities in the RP Care Community Network. RP further develops sites based on the requirements of a protocol and

facilitates submission of feasibility information to the sponsor. In addition to assisting in all document submissions, scheduling, and contract negotiations through successful site activation, RP provides on-going support to ensure rapid recruitment and quality study conduct. **Results:** To date, an Adult Day Services (ADS) community and assisted living facility (ALF) have been piloted as non-traditional sites for a Phase 2 symptomatic-AD trial. Valuable information about the start-up process of a research naive site was collected at the adult day center. Within 35 days of being provided the feasibility questionnaire by the sponsor, the site qualification visit occurred and the site was selected. The site initiation visit (SIV) was completed after an additional 35 days with the site officially activated 22 days later. In total, the start-up process for this non-traditional site was 91 days, or a little over three months. With the average start-up timeline of five to six months, this non-traditional site was activated nearly twice as fast. Recruitment performance data on the ADS was not collected due to study enrollment ending shortly after site activation. However, the ALF site recruited randomized five participants prior to enrollment ending. The ALF site finished as third highest enrolling site study-wide, screening over three times more patients than the study average per site. This success was achieved in four months, which was a fourth of the amount of time to recruit as those sites that were brought on at the onset of the study. **Conclusion:** As Alzheimer's disease clinical trials struggle to recruit and retain robust populations and the pharmaceutical industry turns attention to patient-centered practices and improved efficiencies, non-traditional site participation promises benefits for participants, caregivers, care communities and study sponsors. Based on the 2016 Center for Disease Control (CDC) National Study of Long-Term Care Providers, the number of persons with Alzheimer's populations in nursing homes (630,329), residential care communities (330,738) and adult day centers being (83,249) is significant and growing. Thus, there is great potential for non-traditional clinical trial site development to improve AD clinical trial recruitment. Initial pilot data suggests that developing care communities as non-traditional clinical trial sites is an effective strategy to enhance both the study start-up timeline and recruitment. Follow-up on these initial findings is needed to characterize care communities fit for development as non-traditional sites. Additional data is also needed to understand how this community-based recruitment approach improves the pace, quality and diversity of recruitment to AD trials, as well as participant, caregiver and care community staff satisfaction.

P54: VALIDATION OF ALZHEIMER'S BIOMARKERS: B-AMYLOID 1-42 AND TOTAL TAU IN CSF BY AUTOMATED CLEIA ON LUMIPULSE G 1200 PLATFORM. Satya Nandana Narla¹, Amanda Dider¹, Ming Hu¹, Tina LV², Yuan Xueling², Martine Florent¹ ((1) *Immunology Department, Covance Central Laboratories, Indianapolis, USA*; (2) *Immunology Department, Covance Central Laboratories, Shanghai, China*)

Background: Guideline for Alzheimer's disease diagnosis (AD) suggests using AD biomarkers for the pre-symptomatic and symptomatic phases. Cerebrospinal fluid (CSF) level of β -amyloid 1-42 ($A\beta$ -42) and total Tau proteins have been increasingly included in the diagnostic process of Alzheimer's disease. $A\beta$ -42 is cleaved from amyloid precursor protein which ends up as aggregates in the brain, $A\beta$ -42 plaque depositions are widely used to characterize AD. Analysis of $A\beta$ -42 in CSF of

AD patients shows significant reduction of $A\beta$ -42 concentration. Tau is a neuronal protein which binds to microtubules in the neuronal axons. In healthy controls, levels of total Tau in CSF increase with age. Total tau levels are significantly enhanced in AD patients as compared with age-matched control subjects. Fujirebio (Fujirebio Inc., Japan) has developed fully automated chemiluminescence enzyme immunoassays (CLEIA) for analysis of $A\beta$ -42 and total Tau in CSF. The purpose of this study is to evaluate the performance of these assays as per CLSI guidelines. **Method:** CSF $A\beta$ -42 and total Tau are measured quantitatively by chemiluminescence enzyme immunoassay technology by a two-step immunoassay method on the LUMIPULSE G 1200 (Fujirebio Inc., Japan) using respective immunoreaction cartridges. Both assays were validated at two different sites (USA, Site 1 as primary site and China, Site 2 as secondary) following our validation protocol. **Results:**

Validation Parameter	Experiment design	Results	
		$A\beta$ 1-42	Total Tau
Precision	Both Sites:	Average % CV	Average % CV
	Intra Assay: 3 levels, 20 replicates each, 1 day	Site 1- 1.43	Site 1- 3.50
	Inter Assay: 3 levels, 1 replicate per day, 10 days	Average % CV	Average % CV
		Site 1- 1.66	Site 1- 4.73
Accuracy	- $A\beta$ 42:	All samples within manufacturer's range	All samples within manufacturer's range
	Site 1: 5 proficiency samples for	Avg recovery	Avg recovery
	Site 2: 3 level control material provided by manufacturer for	Site 1- 96%	Site 1- 96%
	- Total Tau:	Site 2- 93%	Site 2- 103%
Analytical Measuring Range (AMR)	Both Sites: 3 level control material provided by manufacturer	AMR= 14 to 2069 pg/mL	AMR= 141 to 1919 pg/mL
	Both sites: 5 levels of CSF spiked with recombinant protein, minimum 3 replicates each	slope	slope
		Site 1- 0.977	Site 1- 1.025
		Site 2- 0.984	Site 2- 1.045
Lower Limit of Quantification (LLOQ)	Site 1: 5 levels, diluent spiked with recombinant protein, 5 replicates each per day, 5 days	LLOQ= 14 pg/mL	LLOQ= 141 pg/mL
	Site 2: 5 levels, diluent spiked with recombinant protein, 2 replicates each per day, 5 days	CV at LLOQ	CV at LLOQ
	Site 1: 10%	Site 1- 12%	
		Site 2- 12%	Site 2- 16%
Dilution Verification	Site 1: Two samples diluted with diluent with 2 fold dilution up to X16, tested in duplicate	10X dilution acceptable	Dilution not allowed as per Package insert
	Site 2: Not applicable	LLOQ= 20,690 pg/mL	LLOQ= 1919 pg/mL
Length of Run	Site 1: 3 levels of QC, over 3 days at three time points (morning, afternoon and evening)	No significant change throughout the day	No significant change throughout the day
	Site 2: Not applicable	NA	NA
Reference Interval/ cut off	Not performed as samples not available	NA	NA
Site to site correlation	40 unique CSF samples tested at both sites in parallel	Slope= 0.973	Slope= 0.968
	Site 1- X method	Intercept= 19.4	Intercept= 6.7
		Corr coef (R)= 0.9938	Corr coef (R)= 0.9743
		X Mean= 426.4 pg/mL	X Mean= 329.7 pg/mL
Site 2- Y method	Y Mean= 434.2 pg/mL	Y Mean= 312.5 pg/mL	
Lot to Lot correlation	5 unique samples were tested on two different lots at site 1	All 5 samples are within 15% bias between lots	All 5 samples are within 15% bias between lots

Conclusion: Lumipulse G $A\beta$ -42 and total Tau are robust quantitative assays and may meet the Clinical and Laboratory Standards Institute (CLSI) requirements. CSF $A\beta$ -42 and Total tau could be proposed in clinical or drug trials as markers for AD according to the guideline.

P59: THE IMPACT OF FRAILTY ON THE RISK OF SCREEN FAILURE IN RANDOMIZED CONTROLLED TRIALS ON ALZHEIMER'S DISEASE. Alessandro Trebbastoni, Marco Canevelli, Giuseppe Bruno, Carlo de Lena, Letizia Imbriano, Fabrizia D'Antonio, Laura Pieroni (*Department of Human Neuroscience, «Sapienza» University of Rome, Italy*)

Background: High screening failure (SF) rate has historically represented a major challenge in the conduction of randomized controlled trials (RCT) on Alzheimer's disease (AD). In fact, SF can significantly delay the randomization process and result in additional costs without contributing valuable data to the

research protocol. Therefore, the identification of easy-to-assess variables consenting to estimate with good approximation the risk of SF among RCT candidates may have important practical implications. Specifically, multidimensional approaches comprehensively capturing the biological age of the individual and his/her global health status could be particularly useful for this purpose. **Objective:** The aim of this study was to investigate if the enrichment of screening procedures by measuring the frailty1 status/biological aging of patients with AD assessed for eligibility in RCT might be useful to predict their subsequent enrollment or exclusion. **Methods:** We retrospectively reviewed the clinical charts of patients with a diagnosis of prodromal AD (pAD) and mild AD (mAD) who were screened for eligibility in phase-III RCTs investigating novel anti-amyloid therapies against AD. The individual frailty/biological aging was measured by means of a Frailty Index (FI) computed by considering 39 deficits (signs, symptoms, diagnoses, disabilities, and laboratory findings). Univariate analyses were used to compare the socio-demographic and clinical characteristics between the enrolled and the excluded participants. **Results:** Ninety-six patients (45 pAD and 51 mAD) were considered for the present analysis. Low frailty levels were detected in the sample (mean FI 0.10; SD 0.05). Overall, the 26.0% of participants resulted as SF. In particular, 18 patients were excluded as they were found amyloid negative at the CSF or PET examination, whereas 7 met other exclusionary criteria (e.g., unconsented concomitant medication, unstable medical condition, specific laboratory findings) precluding their further recruitment. No significant differences were found when we compared the sociodemographic and clinical characteristics as well as the biological aging of patients that were finally enrolled or considered as SF. **Conclusions:** The present findings indicate that the individual's frailty/biological aging is not associated with the outcome of screening procedures (i.e., enrollment vs. exclusion) among patients with a clinical diagnosis of pAD or mAD considered for RCT. No sociodemographic or clinical determinant was found to affect the probability of being finally recruited or not recruited in the considered studies. Accordingly, the inclusion/exclusion of the screened participants was almost entirely based on the positivity/negativity of amyloid assessments. Along the same lines, the amyloid status did not affect at all the phenotypic characteristics of participants. These findings seem to be of particular relevance as this may imply that, in the next future, the identification of "real world" patients eligible to receive novel disease-modifying treatments risks to be essentially based on costly, not widely available, and still poorly reliable procedures. 1. Morley JE, Vellas B, van Kan GA, Anker SD, Bauer JM, Bernabei R, Cesari M, Chumlea WC, Doehner W, Evans J, Fried LP, Guralnik JM, Katz PR, Malmstrom TK, McCarter RJ, Gutierrez Robledo LM, Rockwood K, von Haehling S, Vandewoude MF, Walston J. Frailty consensus: a call to action. *J Am Med Dir Assoc.* 2013 Jun;14(6):392-7. doi: 10.1016/j.jamda.2013.03.022. PMID: 23764209

P61: CONCIERGE SITE SERVICES: SITE-SPECIFIC SUPPORT AND CAPACITY DEVELOPMENT IMPROVES RECRUITMENT PERFORMANCE. Jacobo Mintzer¹, Mike Splaine², Erin Beck³ ((1) *Research and Innovation Center, Roper St. Francis, Charleston, SC, USA; Managing Partner, Recruitment Partners LLC, Columbia, MD, USA;* (2) *Managing Partner, Recruitment Partners LLC, Columbia, MD, USA;* (3) *Director of Site Recruitment and Management, Recruitment Partners LLC, Columbia, MD, USA*)

Background: Preventing Recruitment to Alzheimer's disease (AD) clinical trials is an obstacle course that begins with identifying participants and ends with signing the informed consent form. Although the protocol is universal for a given study, every site experiences a unique obstacle course due to the location, the study team, and the population they serve. A study succeeds or fails in these small details at the site level. In order to enhance the recruitment and general performance of a study, careful attention must be given to the capacity of each site and its study team. Supporting sites with deeply experienced AD researchers and clinicians is a method to enhance site's attention on a specific trial, share best practices, uncover fundamental site-specific barriers and collaboratively generate novel methods for improved recruitment quality and pace. **Methods:** The Recruitment Partners Approach is based on three core concepts: Listen, Respond, Partner. Our team of Recruitment Partners (RP) Experts are renowned clinical trialists and thought leaders. Through introductory and follow-up site visits, RP Experts develop relationships with the principal investigator and study staff that are different from—but complementary to—the typical relationship between sites and a CRO, monitor or sponsor. RP Experts look and listen for unmet needs limiting enrollment performance through structured interviews and observations to gain new insights and present innovative solutions to local site barriers. Activities may include coordinating resources for dedicated staff to mine databases and perform prescreening activities, establishing physician referral sources and agreements, organizing events with care community and civil society organizations, and facilitating improved transportation logistics and resources. Further, RP maps community-level partnerships to refer relevant patient populations to local trial sites as successful recruitment into research, especially at prodromal or early stages of the disease, can be greatly improved through strategic community engagement. RP provides introductions and guidance in the modification, preparation, and distribution of materials and events, including exploring how trials align with community stakeholders' interests and motivations. By staying in close contact with key study staff focused on recruitment, RP provides an independent report of daily issues encountered by the sites. This allows RP to follow-up on unresolved or newly emerged issues and provide the sponsor with a granular understanding of all activities occurring at the site. **Results:** RP Concierge Site Services have effectively enhanced recruitment in a number of Phase 2 and 3 AD clinical trials: RP provided concierge site support to 14 US sites of an approximately 40-site Phase 2 symptomatic study. Excluding sites that were closed or withdrew during the course of the study, RP provided support to 10 sites. On average, these sites had been activated 6 months prior to RP support and had 6 months of RP support. With RP's support, overall monthly site screening rates improved by 92.8%. Of the top three performing RP sites, screening rates increased from an average of 1.3 screens per month to 3.4 screens per month. Prior to RP-support, only

2 patients had been randomized from these 10 sites; however, these sites randomized 14 participants with RP-support. For a different Phase 2 study, RP performed recruitment effectiveness assessments via phone and on-site visits. RP supported 10 of 11 study sites for the final 4 months of the 13 month enrollment period. During this period, the RP-supported sites randomized 63.2% of the total number enrolled randomized for the study. Additionally, RP provided support to 29 of 228 sites in a global Phase 3 study. The study enrolled 1306 participants in total, with RP-supported sites enrolling a total of 272 participants: 113 from Europe (10 sites), 114 from Argentina (16 sites), 45 from Chile (3 sites). On average, RP-supported sites randomized 11.14 participants/site, as compared to the study-wide average of 5.75 participants/site. Six (6) RP-supported sites were in the top 10% highest performing sites study-wide, eleven (11) in the top 20% and twenty-five (25) in the top 50%. RP-supported sites contributed 21% of all study participants while only representing 13% of all study sites. **Conclusion:** Failures to enroll targets in AD clinical trials are rarely due to the sites' lack of access to patients, but rather a lack of capacity and support at the site level for optimal recruitment to a specific protocol. Recruitment Partners Concierge Site Services responds to this gap by connecting highly specialized and experienced RP Experts with study staff to evaluate their unique barriers and potential facilitators for effective recruitment. RP Experts' employ active listening to derive new insights and generate innovative solutions, then relentlessly pursue timely implementation of solutions. This specialized, site-specific capacity development has demonstrated improvement in pace and volume of recruitment across various Phase 2 and 3 AD clinical trials. Future evaluations of Concierge Site Services are needed, including effectiveness based on protocol requirements or other disease areas and characterization site conditions most responsive to specialized recruitment support, including which types of support.

P82: MEOTIS3RC : EFFICIENT NETWORK FOR CLINICAL RESEARCH ON COGNITIVE DISORDERS IN NORTH AND PAS-DE CALAIS. Catherine Adnet-Bonte¹, Brigitte Leprince¹, Laetitia Breuilh^{2,3}, Florence Pasquier^{2,3} ((1) *Meotis, Centre Hospitalier Universitaire de Lille, France*; (2) *Neurology Department, Centre Hospitalier Universitaire de Lille, France*; (3) *Excellence Laboratory DISTALZ, Inserm U1171, Univ Lille*)

Background: Settled in the North of France, the Lille Resources and Research Memory Centre (MRRC) was founded in 1991. It develops translational research and is currently involved in 13 academic clinical studies and 11 clinical trials (phases 1b to 3) of innovative treatments or new radiotracers sponsored by pharmaceutical companies. Among the 4 million inhabitants living in this region, around 7 000 patients have been diagnosed with Alzheimer's disease (AD), but only 10% of them receive care in the MRRC and thus have a direct access to clinical trials. Since 1995, the MRRC coordinates a network of 24 memory clinics throughout the region, with the precious help of the Meotis team which is a hospital-private office network created in 2002 (<http://www.meotis.fr/>). This network uses standardized procedures for diagnosis and follow-up and keeps up-to-date a database recording patients' medical profiles, allowing statistical analysis as well as clinical research feasibilities. The MRRC communicates regularly with the Memory Clinics network about its clinical research activities and some centres have been invited to participate in clinical

studies. Despite their motivation and their patients' active lists, several centres failed in the recruitment process mainly due to lack of medical time, lack of nurse time, logistical issues and inefficient patients identification process. In order to facilitate access to clinical research for all AD patients of the region, and with the precious support of the Conseil Regional and of the Lille University Hospital, we created in August 2013 a mobile clinical research professional's team which is dedicated to the development of clinical research activities in all interested memory clinics of the network. This regional Memory Clinics clinical research network is called «Meotis3RC». **Methods:** Meotis3RC mobile research team involves 1 neurologist, 1 study nurses and 1 study coordinator. Their actions include prescreening, information to the patients and their carers, scheduling, support during screening, baseline and follow-up visits, CRF and/or eCRF data entry... Moreover, the team offers the possibility for home visits. In parallel, Meotis3RC is implied in global awareness and training actions about clinical research for patients and carers, general public and healthcare professionals. The Meotis3RC team reported their activities through different indicators: number of inclusions on the Meotis3RC network, number of prescreening (in collaboration with the site), numbers of MRRC referred, screened and enrolled patients for high technicity clinical trials... **Results:** To date, Meotis team provided its services in 14 investigator sites of the region regarding 3 interventional studies: - COVARAD (NCT01423396) which is funded by the French Clinical Research Hospital Program; - NILVAD (NCT02017340), a FP7 project funded by European Commission; - RH-VAL-2013-01 (NCT02409030), sponsored by Raman Health Technologies, S.L. Since its creation, 14 sites benefitted from this support, 155 patients have been successfully enrolled in these 3 studies. We also noticed empowerment of several investigator sites. Moreover, awareness among professionals raised in turn awareness among patients and their carers. As a result, motivated patients from all over the region have been referred to the RRMC for complex clinical trials. To date, up to 33 patients have been referred to the MRRC, among which 29 have been enrolled in a clinical trial targeting prodromal and mild AD. **Conclusion:** Meotis3RC mobile team is a driving force for clinical research in our region. This AD clinical research network and its mobile team are operational for pharmaceutical companies sponsored clinical trials, allowing faster and better recruitment. Finally, the regular meetings with the Memory Clinics' staffs are key moments to disseminate new concepts in AD research such as clinical trials targeting presymptomatic patients (memory complaints, MCI) or asymptomatic persons. With around 2200 MCI patients followed in the Meotis3RC network in 2014, they will be key actors for coming clinical trials.

P86: RECRUITING OLDER LATINOS IN SENIOR CENTERS WITH A CULTURALLY TAILORED ALZHEIMER'S PRESENTATION. Jaime Perales¹, W Todd Moore¹, Mariana Ramirez¹, Linda Lara², Erica Davis³, Jason Resendez⁴, Eric D Vidoni¹ ((1) *University of Kansas Medical Center, Kansas-USA*; (2) *Guadalupe Center, Kansas City-USA*; (3) *Don Bosco Senior Center, Kansas City-USA*; (4) *LatinosAgainstAlzheimer's Coalition, Chevy Chase-USA*)

Background: Latinos are underrepresented in Alzheimer's disease (AD) clinical research and recruitment of minorities in a high priority in the USA. Factors that may explain this

underrepresentation include low AD literacy, trust in research institutions, transportation issues and cultural and linguistic fit of staff and materials. The aim of this study was to pilot the preliminary effectiveness of Envejecimiento Digno (45-minute culturally-tailored AD knowledge presentation) in recruiting Latino older adults in senior centers. **Methods:** We conducted six bilingual Envejecimiento Digno events at three Latino-affluent senior centers between November 2017 and January 2018 after carefully building partnerships with them. Senior centers advertised the event weeks in advance and we held sessions during opening hours. The presentation included lecturing, videos and interactive activities on what is AD, risk factors, assessment, treatment and resources. All participants received surveys at the beginning of the session asking about their ethnicity. During the presentation's resources section, the presenter gave participants a form to write down their contact information only if they were interested in participating in a cohort study the Alzheimer's Disease Center offered. The cohort study assessments were offered in Spanish or English and at their senior centers and were conducted by the same researcher who delivered Envejecimiento Digno. **Results:** We presented one Envejecimiento Digno fully in Spanish, one in English and four in both languages. We reached 61 older adults including 50 Latinos. Among the 50 Latino participants, 32 (64%) gave their contact information to participate in the cohort study. Of those 32 up to June 2018, 25 (78%) have completed the eligibility form, 16 (50%) have enrolled and 14 (44%) have completed the yearly assessment. Word of mouth from Envejecimiento Digno participants has led to five more participants interested at the same senior centers, four of which have already completed the yearly assessment. **Discussion:** Envejecimiento Digno is an effective tool to recruit Latino older adults. However, this study did not have a comparison group and was not randomized. Future studies should assess Envejecimiento Digno's recruitment effectiveness into AD clinical trials as commitment to interventions adds additional barriers to participation.

P90: REVERSE-SD: ONGOING PHASE-2B STUDY OF NEFLAMAPIMOD DESIGNED IN ACCORDANCE WITH EMERGING SCIENTIFIC AND REGULATORY CONCEPTS OF EARLY ALZHEIMER'S DISEASE (AD). John Alam¹, Kelly Blackburn¹, Niels Prins^{2,3}, Philip Scheltens² (1) *EIP Pharma Inc., Cambridge, MA, USA*; (2) *Department of Neurology and Alzheimer Centre, VU University Medical Center, Amsterdam, NL*; (3) *Brain Research Center, Amsterdam, NL*)

Background: FDA has recently issued guidance regarding development of therapeutics for Early AD, in which pre-dementia phase of the disease is defined as the presence of "pathophysiologic changes of AD" based on biomarkers and increasing cognitive and functional impairment: Stage 1 (preclinical AD), Stage 2 (detectable abnormalities on sensitive neuropsychological measures) and Stage 3 (stage 2, plus mild detectable functional abnormalities). The guidance also acknowledges the value of tests of "neuropsychological performance" to evaluate treatment effects in Early AD. The European Medicines Agency (EMA) also recently a new guidance regarding AD therapeutics and it too defines stages in the pre-dementia phase that can be mapped on to the FDA definitions. Finally, the recently issued NIA-AA framework defines AD primarily around underlying pathophysiology and therefore stages disease by biomarkers of amyloid, tau and neurodegeneration; though, cognitive impairment is defined in

parallel by a six-step staging scheme that is aligned with both FDA and EMA. The ongoing Reverse-SD trial was designed in accordance to these recent guidances. Neflamapimod is a highly selective brain penetrant oral inhibitor of p38 α kinase-activity. In 6- and 12-week duration phase 2a clinical studies in patients with early AD demonstrated within-subject improvement in episodic memory function (Scheltens et al, ACTN, 2018; CTAD, 2016 & 2017); consistent with the potential for reversing synaptic dysfunction derived from preclinical studies. In this abstract, we provide the design of a phase 2b clinical study of neflamapimod in Early AD that has as a primary objective of demonstrating the ability of the drug to reverse synaptic dysfunction ("SD"), as evaluated by episodic memory function. **Methods:** Patients: Aged 55 to 85, with CDR-Global score of 0.5 or 1.0; CDR memory subscore of at least 0.5; MMSE score of 20 to 28, inclusive; positive biomarker for AD, as defined by CSF A β 1-42 below threshold and phospho-tau above threshold; receiving either no AD-specific therapy or on monotherapy (either cholinesterase inhibitor or memantine; dual therapy excluded). Treatment: randomized 1:1 to receive neflamapimod 40 mg capsules or matching placebo capsules twice daily with food for 24 weeks. Primary endpoint: Episodic memory, as assessed by change from baseline to week 24 in combined total (immediate) recall and delayed recall in Hopkins Verbal Learning Test – Revised (HVLT-R) in neflamapimod-treated subjects compared to placebo-recipients. Secondary endpoints: Change in WMS immediate and delayed recall composites, CDR-SB, MMSE, CSF biomarkers (total tau, p-tau181, A β 1-40, A β 1-42, neurofilament light chain, neurogranin) in neflamapimod-treated subjects compared to placebo-recipients. Sample size: approximately 76 patients per treatment arm (152 patients total). Provides 90% statistical power to detect effect size (ES) of 0.53 and 80% to detect ES of 0.46. Assuming a z-score decline of between 0.15 to 0.25 in the placebo-recipient group, neflamapimod treatment would need to show an increase in z-score of at least 0.21 to 0.38 to demonstrate a statistically significant positive treatment effect. This level of treatment effect is substantially lower than the improvements that were seen in phase 2a. Results: Study to be conducted at approximately 40 sites in the Netherlands, Czech Republic, Denmark, United Kingdom and USA (18 sites). First patient dosing occurred in March 2018 in the US under an open IND; national regulatory approvals obtained in EU, with first patient dosing in EU expected in June 2018. Planned six-month enrollment period after all sites are active. The requirement of both amyloid and tau CSF biomarker positivity for inclusion was based on the NIA-AA research framework that defines AD by positive biomarkers for both amyloid and tau pathology. In the assay utilized in this study (Elecsys® Immunoassay), the cut-off for amyloid pathology positivity is well established at A β 1-42 < 1000 pg/mL. However, there is no defined threshold value for tau pathology as there is no in-life gold standard. Rather the cut-offs that have been established for CSF phospho-tau for this and other assays are either against PET-amyloid positivity or a diagnosis of clinical AD. Based on the evaluation of the Elecsys® Immunoassay by Hansson et al (Alzheimer & Dementia, 2018) the current study is utilizing a phospho-tau cut-off of greater than 0.024 for the ratio of P-tau181/ A β 1-42. That ratio was predictive of both PET-amyloid positivity and risk of progression from MCI to AD, which could be considered as a surrogate for tau pathology. Initial screening data suggests that 60-70% of subjects who meet the clinical screening criteria will be positive for the defined CSF AD biomarker positivity, and subjects

who meet both clinical and CSF screening criteria will have impaired episodic memory at baseline. **Conclusion:** Though this study was developed in the year ahead of issuance of the new guidelines, by collaborating with the academic community that also influenced the guideline development, the REVERSE-SD study design is well aligned with FDA, EMA and NIA-AA recommendations regarding clinical study design in Early AD.

P91: A PHASE 2B/3, DOUBLE-BLIND, RANDOMIZED, PLACEBO-CONTROLLED 48-WEEK TRIAL OF ANAVEX@2-73 FOR THE TREATMENT OF EARLY ALZHEIMER'S DISEASE TOGETHER WITH PRECISION MEDICINE GENETIC BIOMARKERS. Stephen Macfarlane¹, Michael Kornhauser¹, Ella Modini¹, Harald Hampel², Stephan Toutain³, Christopher Missling³ ((1) *HammondCare Dementia Centre, NSW - Australia*; (2) *Sorbonne University, Paris - France*; (3) *Anavex Life Sciences Corp., New York - USA*)

Objective: The repeated failure of traditional disease-modifying therapies for Alzheimer's disease (such as gamma secretase inhibitors, monoclonal antibodies targeting beta amyloid) to achieve their primary outcomes in Phase 3 clinical trials has led to a search for new therapeutic targets. We reported positive 5-week and 57-week outcomes of an open-label Phase IIa study of 32 patients using ANAVEX@2-73, a sigma-1 agonist, at CTAD in 2016 and 2017, respectively. **Methods:** A larger international double-blind, randomized, placebo-controlled study of ANAVEX@2-73 in up to 450 patients with early Alzheimer's disease commenced earlier this year. Full exome DNA and RNA of attainable AD patients will be also analyzed. **Results:** The methodology of the trial will be presented, including a discussion of the chosen outcome measures, and an update on the progress of the trial will be provided. **Conclusions:** This is the first larger full genomic analysis study of ANAVEX@2-73 utilizing genetic biomarkers in early Alzheimer's disease patients. Further clinical studies in several other indications are planned or underway. A more complete set of updates will be available at the time of the conference.

P92: AIMPACT OF GENETIC TESTING ON CLINICAL TRIAL PARTICIPATION AND SUBJECT SELECTION, A PILOT STUDY. Marieke Cajal-Berman¹, Jessica Branning², Vishnukartik Nitta² ((1) *Bioclinica Research, Orlando, FL, USA*; (2) *ClinCloud, Orlando, FL, USA*)

Background: In the last few years, Alzheimer's research has progressively changed its focus to earlier stages of the disease, with patients with Mild Cognitive Impairment (MCI) the target of an increasing number of clinical trials. Individuals with MCI display a significant decline in their cognitive abilities that is not yet impacting their ability to function, symptoms which are often difficult to distinguish from normal cognitive aging. Those individuals are at an increased risk of Alzheimer's disease (AD). One of the challenges of MCI clinical trials is the selection of appropriate participants with MCI due to AD. To ensure the right patients are included, MCI trials incorporate a number of cognitive and imaging criteria. These criteria are complex to fulfill and cannot fully be predicted from typical private practice work-ups, resulting in a large number of screen fails. **Objectives:** In order to reduce the number of screen fails in MCI clinical trials, our clinic has been testing the predictive value of pre-screen information on screening performance. Of particular

interest is the predictive value of participants' genetic risk factors. **Methods:** Complimentary APOE testing was offered to 88 participants at pre-screen using the Spartan Cube APOE system (Spartan Bioscience, Ottawa, Canada). The pre-screen also included the collection of demographic information, family history of AD, and the completion of cognitive tests. Memory testing was administered by trained psychometric raters and included the Mini-Mental State Examination (MMSE), the APTest developed by Bioclinica Research, and the California Verbal Learning Test (CVLT). **Results:** Twenty-eight percent of participants were E4 carriers. Of all participants, 40% scored in the MCI range on the different cognitive tests used. When considering only the E4 carriers, this number went up to 52 to 75% scoring in the MCI range depending on the test. E4 carriers scored significantly lower on cognitive testing, pointing towards an increased likelihood of them qualifying based on cognitive criteria at screening in MCI studies. E4 carriers are also at a higher risk for presenting AD biomarkers, such as neurofibrillary tangles and beta-amyloid plaques. **Conclusions:** The availability of cognitive and genetic testing results assisted the investigator in identifying the individuals most likely to score within the MCI range and have elevated levels of beta-amyloid or neurofibrillary tangles on their PET scan at screening, thus reducing the incidence of screen fails.

P93: THE IMPACT OF TRANSCRANIAL MAGNETIC STIMULATION ON DIAGNOSTIC CONFIDENCE IN PATIENTS WITH ALZHEIMER DISEASE ELIGIBLE FOR CLINICAL TRIALS. Alberto Benussi^{1*}, Antonella Alberici^{1*}, Clarissa Ferrari^{2*}, Valentina Cantoni^{1,3}, Valentina Dell'Era¹, Rosanna Turrone¹, Maria Sofia Cotelli⁴, Giuliano Binetti², Barbara Paghera⁵, Giacomo Koch^{6,7}, Barbara Borroni¹, Alessandro Padovani¹ ((1) *Neurology Unit, Department of Clinical and Experimental Sciences, University of Brescia, Brescia, Italy*; (2) *IRCCS Centro San Giovanni di Dio Fatebenefratelli, Brescia, Italy*; (3) *Department of Neuroscience, Psychology, Drug Research and Child Health, University of Florence, Florence, Italy*; (4) *Neurology Unit, Ospedale Vallecaminica, Esine, Brescia, Italy*; (5) *Nuclear Medicine Unit, Spedali Civili Brescia, Brescia, Italy*; (6) *Non Invasive Brain Stimulation Unit, IRCCS Santa Lucia Foundation, Rome, Italy*; (7) *Stroke Unit, Policlinico Tor Vergata, Rome, Italy*; *These authors contributed equally to this work)

Background: Cholinergic dysfunction is a key abnormality in Alzheimer disease (AD) and can be detected in vivo with Transcranial Magnetic Stimulation (TMS) protocols. Although TMS has clearly demonstrated analytical validity, its clinical utility is still debated. In the present study we evaluated the incremental diagnostic value of TMS measure in addition to the routine clinical diagnostic assessment of patients evaluated for cognitive impairment, compared to validated biomarkers of amyloidosis. **Methods:** One-hundred twenty patients with dementia were included and classified as AD or FTD in a three steps' process based on i) demographic, clinical and neuropsychological evaluation (clinical work-up); ii) clinical work-up PLUS amyloid markers (CSF or amyloid PET imaging); iii) clinical work-up PLUS TMS intracortical connectivity measures. Two blinded neurologists were asked to review the diagnosis and diagnostic confidence at each step. **Results:** TMS measures increased discrimination performance when added to the clinical and neuropsychological evaluation with levels comparable to established biomarkers of brain amyloidosis, (cluster distance of 55.1 for clinical work-up alone, 76.0 for

clinical work-up PLUS amyloid markers, 80.0 for clinical work-up PLUS TMS). Classification accuracy, expressed as AUC, increased from 0.82 (clinical work-up alone) to 0.98 (clinical work-up plus TMS) and to 0.99 (clinical work-up plus amyloidosis markers). **Conclusions:** TMS in addition to routine assessment in patients with dementia has a significant effect on diagnosis and diagnostic confidence, comparable to well-established biomarkers of amyloidosis.

P94: APPLYING PATIENT-CENTRED INSIGHTS TO OPTIMIZE PROTOCOL DESIGN AND INCREASE BIOMARKER COLLECTION ACCEPTABILITY IN AD TRIALS. Kenneth Stanley, Carolina Rubel, Lynne Hughes (IQVIA Project Leadership Unit)

Background: The urgent need to accelerate AD drug development in order to bring efficacious therapies to patients more rapidly and to fulfil the ever-expanding AD development pipeline requires better trial design in order to maximize participation and also to assure that participants are retained throughout the study period. It is also clear that trials are getting more complicated with an increased volume of assessments being included increasing the burden on participants and trial sites alike. Traditionally, while researchers like to believe that the needs to the participant are carefully considered when protocols are being developed; the opportunity to get direct participant feedback will inform better designed studies. **Methods:** Detailed questionnaires were designed to collect insights from study stakeholders; including potential patients and their study partners/caregivers, investigators and AD clinical development personnel from sponsor companies. Stakeholders were contacted to get their feedback to these questions to obtain their impressions on items including relative burden of trial participation (frequency, type and length of study assessments for the subject and their study partner), considerations around methods of IP administration (IV, oral etc.) and factors such as duration of study and time commitment needed. Participant feedback was collected through the IQVIA MediGuard Patient Community while trial investigators and sponsor stakeholders were contacted through an on-line survey, with individual follow up on specific questions if clarification or more information was required. Feedback and responses from stakeholders were reviewed and assessed to understand the relative impact of each aspect of study design on the potential impact of trial participation (participant and site) and on the impact of associated workload for trial sites. This was then compared with the current perceptions of trial owner stakeholders within sponsor companies. **Results:** Trial stakeholder feedback confirms that perceptions of stakeholders on trial design features differ depending on the stakeholders. Trial design decisions, especially the types of procedures and the time commitment has the potential to impact greatly trial participation rates and directly affects the interest and commitment of the subject and / or their study partner in the trial. This demonstrates the importance of taking into consideration the feedback from those most directly impacted by trial decisions, i.e. investigator sites and trial participants, before finalizing study designs. **Conclusion:** The insights of trial stakeholders, in particular those of study participants, are extremely valuable in aiding the design of a study that is feasible to execute, and this will increase subject retention and study partner collaboration thus resulting in a more effective clinical trial process

P95: CSF BIOMARKERS OUTCOMES IN THE ETHERAL AD STUDY. Harald Hampel^{1,2,3,4}, Carlos Buesa⁵, Tamara Maes⁵, Mabel Arevalo⁵, Michele Lufino⁵, Roger Bullock⁵ (1) AXA Research Fund & Sorbonne University Chair, Paris, France; (2) Sorbonne University, GRC n° 21, Alzheimer Precision Medicine (APM), AP-HP, Pitié-Salpêtrière Hospital, Paris, France; (3) Brain & Spine Institute (ICM), INSERM U 1127, CNRS UMR 7225 Paris, France; (4) Institute of Memory and Alzheimer's Disease (IM2A), Department of Neurology, Pitié-Salpêtrière Hospital, AP-HP, Paris, France; (5) Oryzon Genomics SA, Barcelona, Spain)

Background: Biomarkers are increasingly reaching and transforming clinical trials for Alzheimer's disease (AD). Indeed, they are essential for several contexts of use (COU) such as the in-vivo proof-of-pharmacology, the identification of individuals at risk (predictive) or with ongoing pathophysiology (diagnostic). Moreover, biomarkers serve as tools to identify subjects likely to respond to a given drug (treatment response) or experience adverse drug effects (safety), to monitor treatment efficacy, and to identify individuals prone to undergo disease progression (prognostic). Most of the clinical trials investigating putative disease-modifying therapies for AD did not employ biomarkers-guided endpoints and outcome measures. Such shortcomings may have actively contributed to misleading results and the overall dramatic failure of trials. It is well known that AD is a complex, multifactorial, biologically heterogeneous disease whose pathophysiological landscape consists of several concurrent mechanisms as brain proteinopathies, cytotoxicity and apoptosis, aberrant immune response and inflammatory responses, and cytoskeletal pathology. Biomarkers reflecting the main AD biological hallmarks, i.e., brain deposition of amyloid-beta (A β), neurofibrillary pathology and neurodegeneration have been already included into research and diagnostic criteria. However, in the last five years several novel candidate biomarkers charting different pathophysiological mechanisms have also been proposed for many potential COU. **Methods and Objectives:** We will analyse screening-baseline (T0) / six months (T1) / one-year (T2) data gathered from ETHERAL AD study which is an international, multicentre, randomized, double-blind, placebo-controlled, 3-arm, 24-week parallel-group study evaluating the safety, tolerability and preliminary efficacy of ORY-2001, a dual Lysine-specific demethylase-1 (LSD1)-Monoamine oxidase type B (MAOB) inhibitor. The target population is represented by patients with mild-moderate AD. As exploratory endpoints, we will seek longitudinal changes in the CSF concentrations of either validated or candidate markers capable to in-vivo tackle distinct AD-related molecular pathways such as neuroinflammation (YKL-40 and S100A9), synaptic dysfunction (neurogranin), cerebral amyloidosis (A β fragment 1-42 [A β 1-42]), neurofibrillary pathology (tau protein phosphorylated at site 181 [p-Tau181]), neurodegeneration (protein Tau total fraction [t-Tau]), and axonal damage (neurofilament light chain [NFL]). As mandatory inclusion criteria, all subjects will undergo CSF assessment for the main AD biological hallmarks, i.e., brain amyloidosis (low values of CSF A β 1-42), neurofibrillary pathology and neurodegeneration (higher values of p-Tau181, and t-Tau respectively). Hence, as a primary objective, we will look for an impact of ORY-2001 on the longitudinal alterations of AD pathophysiological hallmarks. To follow, we will investigate the extent of the association among the different biomarkers and whether ORY-2001 has an impact on the changes over-time of the novel candidate biomarkers. We will carry out an exploratory approach to

achieve key insights about the potential COU(s) of the single biomarker (diagnostic, predictive, prognostic, etc.). Finally and most importantly, we aim at identifying specific clusters (biomarker-profiles) of individuals that can in the future most benefit from ORY-2001 biological effect. **Results:** Data from the early screening samples to be reported where available. **Conclusion:** ORY-2001 is an innovative and promising small molecule with a multi-modal mechanism of action with strong translational evidence supporting its putative biological effect. To our knowledge, this study will be the first comprehensive phase II clinical trial carried out through the implementation of the study design with a broad set of CSF surrogate biomarkers covering all the known AD-related pathophysiological mechanisms. The enrichment of our study with biomarker-guided endpoints will be essential to demonstrate in humans the proof-of-pharmacology which is a prerequisite for every drug with supposed disease-modifying effect. Given the biological heterogeneity of AD, biological markers must drive all steps of clinical trials from subject's proper inclusion, to treatment efficacy and adverse effect monitoring, i.e. those individuals who may most benefit from the biological effect of a drug. Thus, we will fully explore the potential COU(s) that our validated and novel biomarkers may have in future studies. Consequently, our biomarker-driven results might contribute to the current process of biomarker-based re-engineering of drug development, which will enable a better standardization of the product, facilitating quality control. This represents the initial step towards developing a precision neurology approach.

P96: EMIF-AD: A UNIQUE PAN-EUROPEAN PLATFORM FOR LARGE-SCALE RESEARCH ON BIOMARKERS AND RISK FACTORS FOR ALZHEIMER'S DISEASE.

Preciosa M Coloma¹, Stephanie J. B. Vos², Isabelle Bos², Andy Simmons³, Rik Vandenbergh⁴, Philip Scheltens⁵, José Luis Molinuevo^{6,7}, Flavio Nobili⁸, Sebastiaan Engelborghs^{9,10}, Giovanni Frisoni^{11,12}, Gaël Chetelat¹³, Alberto Lleó¹⁴, Anders Wallin¹⁵, Julius Popp^{16,17}, Pablo Martinez-Lage¹⁸, Gonzalo Duran-Pacheco¹, Pieter Jelle Visser^{2,5}, Mark F Gordon¹⁹, Gerald Novak²⁰ ((1) *Personalised Health Care - Data Science, F. Hoffmann-La Roche AG, Basel, Switzerland*; (2) *Department of Psychiatry and Neuropsychology, Alzheimer Center Limburg, Maastricht University, Maastricht, the Netherlands*; (3) *Institute of Psychiatry, Kings College, London, UK*; (4) *University Hospital Leuven, Leuven, Belgium*; (5) *Alzheimer Center, VU University Medical Center, Amsterdam, the Netherlands*; (6) *Alzheimer's disease & other cognitive disorders unit, Hopsital Clínic-IDIBAPS, Barcelona, Spain*; (7) *Barcelona Beta Brain Research Center, Fundació Pasqual Maragall, Barcelona, Spain*; (8) *Clinical Neurology, Department of Neurosciences (DINOGLMI), University of Genoa and IRCCS Polyclinic San Martino Hospital, Genoa, Italy*; (9) *Department of Neurology and Memory Clinic, Hospital Network Antwerp (ZNA) Middelheim and Hoge Beuken, Antwerp, Belgium*; (10) *Reference Center for Biological Markers of Dementia (BIODEM), Institute Born-Bunge, University of Antwerp, Antwerp, Belgium*; (11) *University of Geneva, Geneva, Switzerland*; (12) *IRCCS Istituto Centro San Giovanni di Dio Fatebenefratelli, Brescia, Italy*; (13) *Inserm, Inserm UMR-S U1237, Université de Caen-Normandie, GIP Cyceron, Caen, France*; (14) *Department of Neurology, Hospital de la Santa Creu i Sant Pau, Barcelona, Spain*; (15) *University of Gothenburg, Sahlgrenska Academy, Institute of Neuroscience and Physiology, Section for Psychiatry and Neurochemistry, Gothenburg, Sweden*; (16) *Geriatric Psychiatry, Department of Mental Health and Psychiatry, Geneva University Hospitals, Switzerland*; (17) *Department of Psychiatry, University Hospital of Lausanne,*

Lausanne, Switzerland; (18) *CITA-Alzheimer Foundation, San Sebastian, Spain*; (19) *Teva Pharmaceuticals, Malvern, PA, USA*; (20) *Janssen Pharmaceutical Research and Development, Titusville, NJ, USA*)

Background: The overall objective of the European Medical Information Framework – Alzheimer's Disease (EMIF-AD) is to improve the design of interventional studies for early AD. To this end, it aims to discover and validate diagnostic markers, prognostic markers and risk factors for AD by combining existing datasets containing clinical and biomarker data across the clinical AD spectrum. These datasets, however, are dispersed across Europe. Currently there is no overview of the available cohorts and data available within EMIF-AD. **Objective:** To present an overview and summary characteristics of the cohorts within the EMIF-AD platform. **Methods:** Metadata were collected on more than 50 AD-related cohorts in Europe (comprising >80,000 participants) using a structured questionnaire to characterise individual cohort data elements, study assessments and procedures. Fourteen cohorts agreed to store and share patient-level data via transMART, a secure data platform: ADDNEUROMED; Amsterdam; Antwerp; DESCRIPA; EDAR; Gothenburg; IDIBAPS; Lausanne; Leuven; PharmaCog; Sant Pau; IMAP; GAP; and Genoa. In order to enable this centralised repository, EMIF-AD addressed cohort, country, or regional issues regarding privacy and data sharing. Data from these 14 cohorts were used to generate cohort summary statistics describing baseline demographics, medical history, cognitive test scores, and biomarker results. Multivariable analysis was done across the different cohorts using principal component analysis (PCA) with the variables age, education, and standardised scores on pre-specified priority attention, executive, language, and memory tests. **Results:** Overall, the EMIF-AD cohorts comprised 3411 participants with 43.6% males and mean age 70.2 years (sd 8.6) at baseline. Maximal duration of cohort follow-up ranged from 18 to 96 months. No follow-up data of the Leuven, GAP and Genoa cohorts were available for analyses. Across all the 14 cohorts there were 835 (24.5%) cognitively normal (CN) participants, 403 (11.8%) with subjective cognitive decline (SCD), 1570 (46.0%) with mild cognitive impairment (MCI), 526 (15.4%) with dementia due to AD, 57 (1.7%) with dementias other than AD, and 20 (0.65%) with unknown diagnosis. By design, the cohorts had varying distribution of clinical diagnosis at baseline; e.g., Leuven enrolled only CN subjects (N=180), while PharmaCog enrolled only subjects with MCI (N=147). PCA (Figure 1) showed that despite the high level of heterogeneity across cohorts, the different clinical diagnoses could be identified as reasonably separate clusters in the pooled sample. At the same time, some overlap between the diagnostic clusters remains and this is a reflection of AD being a continuum. Overall, participants had a mean of 10.7 (sd 4.4) years of education; median years of education varied between 8 [IQR 8] years in Genoa to 14 [IQR 9.5] years in Sant Pau. ApoE ε4 carrier status was available for most, but not all, participants and positive ApoE ε4 ranged from 30.8% to 62.7%. Information on family history of dementia or AD was collected in DESCRIPA (37.5% for first degree relatives), EDAR (43.3% for first degree relatives), IDIBAPS (49.6% overall) and SantPau (74.6% with dementia in either parent). MMSE scores were available in all cohorts, mean values ranging from 23.0 (sd 4.9) to 29.1 (sd 0.9), while Clinical Dementia Rating (CDR) scores were available only in some cohorts. Data on CSF biomarkers (amyloid

beta1-42, total tau, and phosphorylated tau) were available in all cohorts except for ADDNEUROMED, Leuven, IMAP and Genoa. Data on brain amyloid burden, as measured by PET standardised uptake value ratio (SUVR), was available in Leuven, Sant Pau, and IMAP. There was some variability in the type of other imaging data collected and consisted mostly of structural MRI; FDG-PET was available for some participants in Genoa and IMAP. Comorbid conditions such as cardiovascular disease, cerebrovascular disease, psychiatric and neurological disorders, and to a lesser degree, type 2 diabetes and cancer, were commonly reported at baseline (data not shown); however study inclusion/exclusion criteria may have influenced such information. **Conclusions:** EMIF-AD has brought together in one repository 14 highly characterised European cohorts representing 3411 individuals across the AD spectrum. This summary of cohort characteristics reflects the fact that each cohort was established with different objectives and collected data using various protocols; furthermore for some cohorts only a subset of the data was uploaded to transSMART. This project demonstrates the strength of research collaboration and the unique opportunity to increase research capacity by integrating access to and analysis of several datasets, while addressing issues such as data sharing and data privacy. The EMIF-AD Platform paves the way for replicating prior research studies, developing new biomarkers and outcome measures, and generating and testing new hypotheses, leading to improved interventional clinical trials and possible novel therapeutics for patients along the AD spectrum.

Figure 1

Principal component analysis (PCA) across all cohorts based on the following baseline variables: age, level of education and standardised scores from pre-specified priority tests for attention, executive function, language and memory (immediate and delayed). Characterisation of participants based on these variables showed reasonable consistency in terms of classifying clinical diagnoses across the cohorts, although still with some degree of overlap

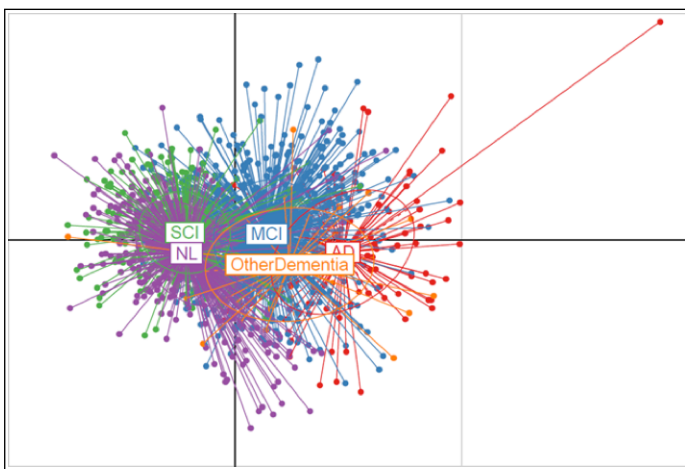

P97: USING TRANSCRIPTION PHENOTYPES TO UTILISE BASKET TRIAL METHODOLOGY FROM ONCOLOGY TO CREATE NEW TARGETS IN CNS DISORDERS. Roger Bullock¹, David Rotllant¹, Michele Lufino¹, Cristina Mascaro¹, Carlos Buesa¹, Tamara Maes¹, Sonia Gutierrez¹, Marta Valverde², Tony Ramos² ((1) *Oryzon Genomics, Barcelona, Spain*; (2) *Vall D'Hebron Hospital, Barcelona, Spain*)

Background: Basket trials are commonly used in oncology, where one mutation may produce different effects in different tissues. This allows a trial of one compound in different indications, usually in an open-label adaptive design, in order to prove concept and target the most effective areas to conduct a more definitive study. They are not yet used in CNS disorders, partly because the common diseases are deemed clinically distinct and researched very separately. ORY-2001 is a small molecule, brain penetrant drug that modifies transcription in the brain and has a host of epigenetic effects, including increasing neuroplasticity and decreasing neuro-inflammation. Of particular interest in behaviour and especially aggression, is the effect of ORY-2001 on the response of immediate early genes (IEGs) like c-Fos in the prefrontal cortex (PFC), which corrects the stress response deficit of these genes in SAMP8 mice. The activation of excitatory neurons in the PFC is key to the control of intermale aggression, and IEGs like c-Fos are widely used markers of neuronal activation. Modulation of IEGs by ORY-2001 may contribute to the treatment of behaviour alterations in multiple CNS conditions – both neurodegenerative and neurodevelopmental. This particular mode of action may explain the improvements seen with ORY-2001 in preclinical studies on aggression and social behaviour alterations. If alterations in the transcription response of IEGs in the PFC are accepted as a part of a phenotype which then manifests itself as an exaggerated response to stress, often in the form of aggression, then a basket study can look at reducing aggression across multiple indications with a single compound; using similar methodology and statistical analyses as oncology basket studies. **Objectives:** To identify a transcription phenotype for aggression, and evaluate the inclusion of four disorders (Alzheimer's disease, Parkinson's dementia/dementia with Lewy bodies, adult autistic spectrum disorder and borderline personality disorder) in a basket trial chosen because in these cases an abnormal stress response is thought to contribute to the development of the observed aggression. **Methods:** Resident intruder test: measures the number of clinch attacks on an intruder, in treated vs non-treated elderly SAMP8 mice. This is a measurement of aggression. Gene expression analysis: alteration of the gene expression response in SAMP8 vs SAMR1 mice strains was performed by microarray based gene expression survey and qRT-PCR validation. Data mining: datasets were downloaded from NCBI GEO and expression levels or changes were analyzed. **Results:** Resident intruder test – clinch attacks were very frequent in vehicle treated SAMP8 but no more frequent in ORY-2001 treated SAMP8 animals than control mice. Aggression was removed without sedation or any effect on function. Gene analysis showed modulation of IEGs in the PFC of SAMP8 mice. Data mining showed that altered regulation of IEGs was encountered in other mice strains with aggression and broadly associated with aggression across species. Data mining further showed that altered regulation of IEGs is frequently present in human CNS diseases and psychiatric disorders with frequent aggressive behaviour. **Conclusions:** Many aspects of behaviour disorders often seen in CNS and psychiatric disorders

are removed by ORY-2001 in different animal models and across different behavioural paradigms, including aggression. This is a new approach in treating these alterations, that does not involve sedation and to date, no unpleasant side effects. ORY-2001 is currently in Phase II AD and MS studies, where some of these behaviour alterations present. Consequently, the time is right for a basket trial in humans with behaviour alterations, particularly manifesting as aggression, across multiple CNS conditions to explore whether a) one targeted approach can resolve the same behaviour alteration across multiple conditions and b) whether the concept of disease transcription phenotyping is a model that increases treatment options for behaviour alterations in CNS/psychiatry studies.

P98: CAN ONLINE REGISTERS WITH SMALL AMOUNTS OF PHENOTYPIC DATA REDUCE SCREEN FAILURE RATES IN ALZHEIMER'S DISEASE TRIALS? Piers Kotting¹, Kris Beicher², Adam Smith³, Clare Shaw² (1) University of Exeter Medical School, Exeter, UK; (2) University of Leeds, Leeds, UK; (3) Institute of Neurology, University College London, London, UK

Background: Recruitment of people into clinical trials in dementia is widely documented to have a number of structural issues. Two well-documented issues are identification of potential participants and high screen failure rates. The introduction of biomarker inclusion criteria and a trend towards trials in earlier disease-stage populations has made identification of participants increasingly difficult through clinical services and driven screen failure rates towards 70-90%. In 2015 an online and telephone service was launched in the UK to facilitate public engagement in, and recruitment to, dementia research studies. Volunteers registering supply data about their diagnosis, prescriptions, comorbidities, and demographics. In the 3 years since launch Join Dementia Research has attracted 34,000 volunteers and been used by 970 researchers across 205 research organisations to support recruitment to 205 commercial and academic studies. **Objectives:** The objective was to assess the performance of Join Dementia Research on recruitment to the commercially-sponsored clinical trials that have used the service since launch. In particular to look at whether the register has had an impact on either the identification of potential participants, or screen failure rates. **Methods:** Activity data was obtained directly from the Join Dementia Research system for every commercial trial to have used JDR to recruit during the first 36 months of the service, and within each trial, for every site that used the service to recruit. The disease stage of the population being studied in each trial was assessed from the trial inclusion and exclusion criteria, with populations allocated to one of three categories: (1) prodromal/MCI/early AD (2) mild to moderate disease (3) healthy controls. Data on total UK trial recruitment was taken from the National Institute for Health Research Open Data Platform. **Results:** Over the 3 year period Join Dementia Research has supported recruitment to 34 commercially-sponsored trials, all of which were included in the analysis. The total number of potential participants pre-screened through Join Dementia Research was 15,492. Total enrolment via the service was 366 participants, 19% of total UK recruitment to those trials. Screen failure rates ranged from 0% to 100%, with a mean of 40%, standard deviation 32% and variance 10%. The distribution of screen failure rates is shown in figure 1. An ANOVA [$F(2,31)=1.51$, $p=.236$] was conducted between the three groups: Prodromal/MCI/early AD $n=12$, mean 50%, SD 28%; mild to moderate disease $n=18$, mean 38%,

SD 32%; healthy controls $n=4$, mean 19%, SD 32%. There was a moderate positive Pearson Correlation ($.401$, $p=0.19$) between the screen failure rate and the number of JDR volunteers pre-screened. **Conclusions:** While it is not easy to ascertain the degree to which Join Dementia Research is providing sites access to new populations, anecdotal feedback from research teams is that often their first port of call is still to their local registers and clinical caseloads, turning to JDR for additional people to screen. This suggests the register is having a positive impact on the identification of participants. Given that this analysis covers the period from launch, and during the first year the numbers of volunteers in the system was low, that Join Dementia Research supplied 19% of all enrolment bodes well for the future, with the number of registrants growing steadily year-on-year. While it was not possible to compare performance of Join Dementia Research with the overall site performance for these 34 trials, the mean screen failure rate was lower than those commonly quoted. Screen failure rates increased as expected according to the population being recruited, with highest screen failure rates in the prodromal/MCI/early AD population. However, even in this group, across the 12 trials the average was 50% with a maximum of 84%. The positive correlation between the number of people pre-screened and the screen failure rate can be explained by the larger numbers of people that needed to be pre-screened to find eligible subjects in the prodromal/MCI group, in which there is also a higher screen failure rate. Given the length and cost of site screening, reducing screen failure rates will both reduce the burden on participants and provide a significant cost saving. Since its launch Join Dementia Research has seen widespread uptake by researchers and has been used by all the commercial contract trials open in the UK. This analysis suggests that online registries containing slim phenotypic data – and no biomarker data – such as Join Dementia Research, can have a positive impact both on increasing participant identification and reducing screen failure rates in early stage disease trials. As the number of volunteers registered increases, it is expected that the use of Join Dementia Research will increase, becoming increasingly a first port of call for researchers and therefore delivering increasing value to trial sponsors.

Figure 1
Distribution of screen failure rates in the 34 trials

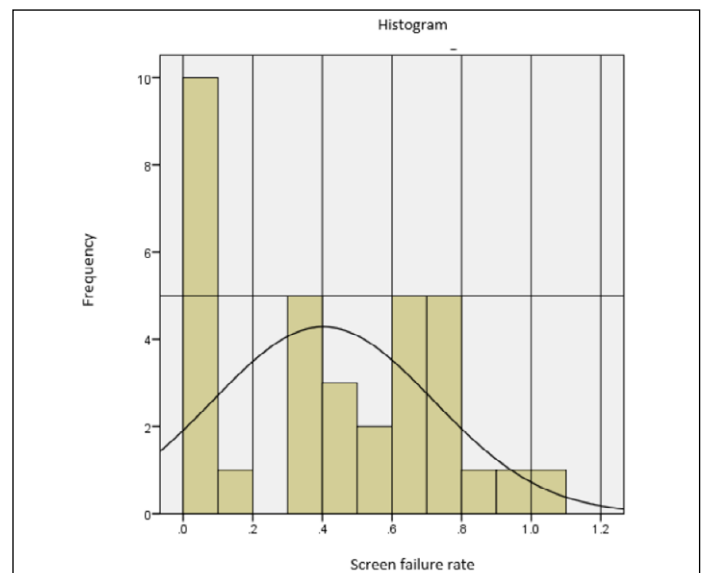

P99: TRIAL DESIGN OF THE GRADUATE STUDIES: PHASE III, RANDOMIZED, PLACEBO-CONTROLLED STUDIES EVALUATING GANTENERUMAB IN PATIENTS WITH EARLY ALZHEIMER'S DISEASE. Smiljana Ristic¹, Mercè Boada², Nathalie Pross¹, Danielle Abi-Saab¹, Szofia Bullain¹, Mirjana Andjelkovic¹, Paul Delmar¹, Carsten Hofmann¹, Alison Searle³, Monika Baudler¹, Paulo Fontoura¹, Rachelle Doody⁴ ((1) *F. Hoffmann-La Roche Ltd., Basel, Switzerland*; (2) *Barcelona Alzheimer Treatment and Research Center, Barcelona, Spain*; (3) *Roche Products Ltd., Welwyn Garden City, UK*; (4) *Genentech, Inc., South San Francisco, CA, USA*)

Background: Gantenerumab, a fully human, anti-amyloid beta (A β) monoclonal immunoglobulin G1 antibody that binds to and promotes the removal of aggregated A β (oligomers, fibrils and plaques), is under investigation as a disease-modifying treatment in early (prodromal to mild) Alzheimer's disease (AD). Post hoc analyses conducted following the pre-planned futility analysis of the Phase III SCarlet RoAD study (NCT01224106) suggested that higher doses of gantenerumab were required to achieve a clinical effect associated with the observed brain amyloid positron emission tomography (PET) standardized uptake value ratio (SUVR) reduction. As a result, both SCarlet RoAD and Marguerite RoAD (NCT02051608) Phase III studies were converted into open-label extension (OLE) studies designed to evaluate the safety and tolerability of gradual up-titration of gantenerumab doses up to 1200 mg. Based on these studies demonstrating significant amyloid removal and with dose titration reducing the risk of amyloid-related imaging abnormalities (ARIA), two new Phase III studies (GRADUATE I, NCT03444870; GRADUATE II, NCT03443973) were designed to assess the efficacy and safety of gantenerumab in patients with early AD. **Objectives:** To describe the study design for the ongoing GRADUATE studies. **Methods:** GRADUATE I and II are identical, randomized, multicenter, double-blind, placebo-controlled, parallel-group, Phase III studies to evaluate the efficacy and safety of gantenerumab in patients with early (prodromal-to-mild) Alzheimer's disease. In each study, approximately 760 patients recruited worldwide will be randomized 1:1 to receive subcutaneous (SC) gantenerumab or placebo. Eligibility criteria include age 50 to 90 years old, clinical diagnosis of prodromal AD (mild cognitive impairment due to AD) or probable AD dementia according to the National Institute of Aging/Alzheimer's Association (NIA/AA) diagnostic criteria, demonstrated abnormal memory and function at screening using the Free and Cued Selective Recall Test (FCSRT), the Mini-Mental State Examination (MMSE), and the Clinical Dementia Rating-Global Score (CDR-GS) and evidence of underlying AD pathology confirmed by either cerebrospinal fluid (CSF) analysis or amyloid PET scan. Following the baseline assessment, eligible randomized patients will receive placebo or gantenerumab via an optimized titration schedule of monthly subcutaneous doses of 120 mg for 3 months, followed by 255 mg for 3 months, 510 mg for 3 months, then 1020 mg per month until the end of the study. The same titration regimen will be used regardless of the patient's APOE ϵ 4 status. A brain magnetic resonance imaging (MRI) examination will be conducted prior to every dose increase and according to the schedule of assessments. The primary efficacy endpoint is change in CDR-Sum of Boxes (CDR-SOB) from baseline to Week 104. Secondary efficacy endpoints include change from baseline to Week 104 in Alzheimer Disease Assessment Scale-Cognition, Subscale 11

(ADAS-Cog11) and ADAS-Cog 13, MMSE, Verbal Fluency, Coding, Functional Activities Questionnaire (FAQ), Alzheimer Disease Cooperative Study Group-Activities of Daily Living (ADCS-ADL). Safety will be monitored throughout the study. MRI examinations will be used to monitor safety and measure brain volumetric changes. Change from baseline in brain amyloid load and brain tau load will also be assessed in a subset of patients. An independent data monitoring committee will regularly evaluate patient safety. **Conclusion:** Building on the key learnings from the SCarlet RoAD double-blind study and the SCarlet RoAD and Marguerite RoAD OLE studies, the new Phase III studies (GRADUATE I and II) are designed to evaluate the clinical efficacy and safety of gantenerumab, compared with placebo, in patients with early AD.

P100: STUDY ENROLLMENT AND ALZHEIMER'S DISEASE PATHOLOGY IN RELATION TO COHORT TYPE AND PARTICIPANT CHARACTERISTICS IN THE EPAD REGISTRY. Lisa Vermunt¹, Graciela Muniz-Terrera^{2,3,4}, Lea ter Meulen¹, Colin Veal⁵, José Luis Molinuevo⁶, Pierre-Jean Ousset^{7,8}, Niels D Prins^{1,9}, David Porteous², Craig W Ritchie², Philip Scheltens¹, Gerald Luscan¹⁰, Anthony J Brookes⁵, Pieter Jelle Visser^{1,11} ((1) *VU University Medical Center, Amsterdam – Netherlands*; (2) *University of Edinburgh, Edinburgh – Scotland*; (3) *University of Victoria, Victoria – Canada*; (4) *University of Cambridge, Cambridge – England*; (5) *University of Leicester, Leicester – England*; (6) *Barcelona Beta Research Center, Barcelona – Spain*; (7) *Clinic University Hospital, Barcelona – Spain*; (8) *CHU Toulouse, Gérontopôle and INSERM UMR 1027, Toulouse – France*; (9) *Brain Research Center, Amsterdam – Netherlands*; (10) *Pfizer, Paris – France*; (11) *Maastricht University, Maastricht – Netherlands*)

Background: Selection of participants for pre-dementia Alzheimer's disease (AD) trials is challenging and often delays trial completion. The European Prevention of Alzheimer's Dementia (EPAD) Registry applies a new method, selecting individuals without dementia from ongoing cohort studies, using existing data in these cohorts for prescreening. The cohorts collaborating with EPAD differed in their original aims, sample size, participant engagement level, and prescreening data. These are all factors that may impact trial recruitment. Knowledge on how participant and study factors associate with enrollment into AD research studies, and with the presence of amyloid and tau pathology will help to develop novel recruitment strategies for pre-dementia trials. **Objective:** The aim is to investigate which cohort-related factors are associated with percentage enrollment and CSF amyloid-beta positivity into the EPAD Longitudinal Cohort study (EPAD-LCS), which is a trial readiness cohort from which individuals will be selected for the EPAD proof of concept trials. We included individuals from 4 different settings: a memory clinic-based cohort (French Trial Registry); a cohort of cognitively unimpaired participants with interest in AD research (ALFA); a population-based cohort (Generation Scotland); and a web-based registry (Dutch Brain Health Registry). **Methods:** The selection process consisted of 4 steps. In step 1, we selected participants from the 4 cohorts using risk algorithms in the PREPAD tool1. In step 2, the cohorts checked eligibility of the individuals, using existing data from their database and in the population-based cohort an opt-in letter was sent. In step 3, the EPAD-sites performed a telephone screen to check inclusion and exclusion criteria. In step 4, individuals were included in the EPAD-LCS and a lumbar puncture was performed

to determine CSF amyloid-beta levels. The first outcome is percentage of individuals enrolled and the second outcome CSF amyloid-beta positivity in those individuals. The predictors for enrollment and amyloid positivity are age, sex, education level, APOE genotype, memory score, MCI diagnosis, subjective complaints, and family history for dementia. Analyses will be updated after the EPAD data release in mid-June 2018. **Results:** We selected 3006 individuals without dementia from the 4 cohorts (table 1). Of those, 1016 individuals were invited for the EPAD-LCS, of whom 427 (14%) agreed to participate. Of the enrolled participants with preliminary CSF results, 29% were classified as amyloid-beta positive. There were large differences in percentages of individuals that enrolled between cohorts, yet the CSF amyloid-beta positivity percentages were similar. The database eligibility check was most effective in the memory clinic and volunteer cohort. **Conclusion:** The setting of the cohort used has a major impact on the percentage of individuals recruited for the EPAD-LCS and is highest for a memory clinic setting and lowest for a population-based setting. However, absolute numbers were highest for the volunteer cohort and web-based cohort. Pilot CSF data suggested that amyloid-beta positivity for those enrolled in the EPAD-LCS is similar across the 4 settings. This would suggest that preselection through a web-based cohort provides the largest number of amyloid positive individuals. References: 1. Vermunt L, Veal CD, ter Meulen L, Chrysostomou C, van der Flier W, Frisoni GB, Guessous I, Kivipelto M, Marizzoni M, Martinez-Lage P, Molinuevo JL, Porteous D, Ritchie K., Scheltens P, Ousset P-J, Ritchie CW, Luscan G, Brookes AJ, Visser PJ (2018) European Prevention of Alzheimer's Dementia Registry: Recruitment and prescreening approach for a longitudinal cohort and prevention trials. *Alzheimer's & Dementia*. In press. The research leading to these results has received support from the Innovative Medicines Initiative Joint Undertaking under grant agreement n°115736.

Table 1
Preliminary results of recruitment flow EPAD-LCS

Cohort	French Trial Registry	ALFA	Generation Scotland	Pilot Dutch BIR	Total
Cohort setting	Memory clinic	Research volunteers	Population based	Web-based	
Total sample in EPAD Registry	173	2163	13486	426	16248
Step 1 Selection by PREPAD tool	141	733	1843	289	3006
Step 2 Eligibility check at cohort					
Excluded	12	428	1491	69	2000
• Meets exclusion criterion	10	147	1	29	187
• Other (e.g. In other study)	2	281	45	40	368
• No response to invitation letter	NA	NA	1445	NA	1445
Selected for step 3	129	305	362	220	1016
Step 3 Eligibility check at EPAD-site					
Excluded	54	118	288	119	579
• Meets exclusion criterion	0	46	11	23	76
• No interest to participate	54	26	178	82	327
• Other (e.g. No study partner)	0	46	99	14	189
Selected for step 4 (4% from step 1)	75 (53%)	187 (26%)	64 (3%)	101 (35%)	427 (14%)
Selected for step 4 in % from step 3	58%	61%	18%	46%	42%
Step 4 Baseline visit EPAD-LCS					
CSF amyloid beta analyzed	65	108	63	63	299
CSF amyloid beta abnormal	22 (30%)	25 (23%)	22 (35%)	19 (30%)	88 (29%)

PREPAD tool= platform used for selection in EPAD Registry. EPAD-LCS=EPAD longitudinal cohort study

P101: THE EFFECTS OF PARTICIPANT CHARACTERISTICS AND SELECTION CRITERIA ON ALZHEIMER DISEASE CLINICAL TRIAL OUTCOMES. Richard E. Kennedy¹, Guoqiao Wang², Mackenzie E. Fowler³, Gary R. Cutter⁴, Lon S. Schneider⁵ ((1) Department of Medicine, University of Alabama at Birmingham, USA; (2) Division of Biostatistics, Washington University, St. Louis, USA; (3) Department of Epidemiology, University of Alabama at Birmingham, USA; (4) Department of Biostatistics, University of Alabama at Birmingham, USA; (5) Department of Psychiatry and the Behavioral Sciences, Keck School of Medicine of the University of Southern California, Los Angeles, USA)

Background: With the limited success of AD and MCI clinical trials to date, novel trial designs and post-hoc analysis of failed trials are increasingly being used to try to identify nascent therapeutic effects. However, such approaches can be adversely influenced by the participant's characteristics of the trial, particularly for the small differences in outcomes that are targeted in AD clinical trials. **Objectives:** We examined how a number of features of clinical trials may affect clinical trial outcomes: ApoE carrier status as a predictive biomarker or as a post hoc stratification variable; Aβ biomarkers; proportion of minorities in trials, age distribution of AD subjects, cognitive severity at baseline, gender distribution, use of donepezil and memantine, and adaptive designs. **Methods:** We used a combined database of 18 clinical trials and observational studies yielding 6553 potential participants to systematically examine the patient characteristics above using clinical trials simulations and modeling. **Results:** First, we demonstrated how imbalances can occur in analysis of AD clinical trials as a result of sample sizes, post-hoc analyses, and novel trial designs. Next we show quantitatively, how variations in the distributions of age, gender, cognitive level, APOE carrier status, and concomitant use of donepezil and memantine substantially affect the effect sizes of clinical outcomes. As examples, concomitant use of cholinesterase inhibitors is associated with a faster rate of decline on the ADAS-cog of 1.4 points/year, and concomitant use of cholinesterase inhibitors and memantine is associated with a faster rate of decline of 1.9 points/year. Differences in age are associated with a difference of 1.4 points on the ADAS-cog at baseline and a faster decline of 0.4 points/year. Finally, we show how adaptive designs depend on the interplay of sample size and recruitment rates in order to be efficient. **Conclusions:** Many participant characteristics affect change in ADAS-cog scores, a standard outcome for AD clinical trials. Subtle changes in participant characteristics can lead to changes in ADAS-cog scores that are comparable or even substantially greater than the size of the hypothesized effect of therapeutic agents for AD. Thus, differences in participant characteristics have likely obscured therapeutic effects (or lack of therapeutic effects) on changes in the ADAS-cog that are routinely used in AD clinical trials, and in particular for post-hoc analyses, age, severity, and gender. Even the most straightforward and traditional clinical trial designs in AD require careful planning of trial design to avoid inadvertent bias and inaccurate conclusions introduced by variations in participant characteristics.

Figure

Effect of age (in 10-year intervals) on ADAS-cog outcomes. A, mean scores observed across clinical trials; B, predicted change over a 24-month trial based on mixed effects modeling

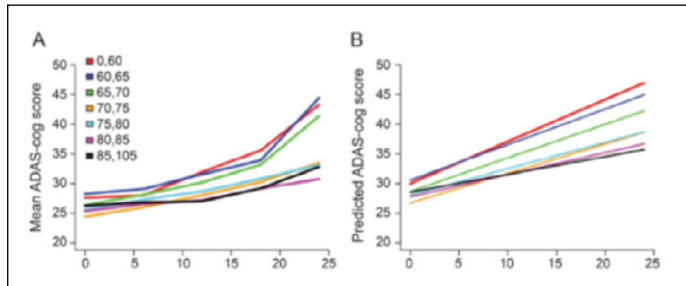

Theme: Clinical trials: Results

P7: EFFECTS OF VORTIOXETINE ON COGNITIVE FUNCTIONS IN PATIENTS WITH ALZHEIMER'S DISEASE AND DEPRESSIVE SYMPTOMS: INTERIM RESULTS OF AN OBSERVATIONAL STUDY. Eduardo Cumbo, Silvia Cumbo, Salvatore Torregrossa, Daniela Migliore (*Neurodegenerative Disorders Unit, ASP 2 Caltanissetta, Caltanissetta (Italy)*)

Background: Depressive symptoms are common in Alzheimer's disease (AD). Their prevalence varies enormously due to several factors including different methods by which depression was diagnosed, differences in study populations etc. The use of antidepressants is therefore very common among patients with dementia. Vortioxetine is a new "multimodal" antidepressant with a complex and not entirely known mechanism of action, which targets the neurotransmitter serotonin. The 5-HT system not only plays a critical role in the regulation of mood, but is also involved in the regulation of cognitive function, as evidenced by pre-clinical and clinical studies. For these reasons vortioxetine unlike other antidepressants has the potential to improve cognitive function. In recent years a number of studies have been published describing its effects on cognition in subjects with depression. However, to date, no studies have been conducted on elderly patients with dementia. **Objectives:** aim of the present study was to compare the effects of vortioxetine versus other conventional antidepressants on cognitive functions in elderly patients with mild AD and depressive symptoms in routine clinical care. Here, interim results from an observational study, that is still underway to achieve a period of observation of at least one year, are reported. **Methods:** Patients were randomly assigned (1:2) to vortioxetine, 10 mg/day, (n= 35), or to other common antidepressants (n= 70) in a case-control study and were prospectively followed. Drug effects on cognition were evaluated cross-sectionally at baseline and 6 months, after dose adjustment therapy, using the following neuropsychological tests: Mini Mental State Examination (MMSE, tests a number of different mental abilities, including memory, attention and language), Attentive Matrices (AM, measures selective and the sustained attention), Coloured Progressive Matrices (CPM, measures nonverbal reasoning ability), Digit Span (evaluates short-term verbal memory). Depressive symptoms were assessed using the Hamilton Depression Scale (HAM-D, 17-item version) and the Cornell scale for depression. The primary efficacy end point was the change from baseline to month 6 in

the MMSE, AM, CPM and Digit Span total scores. Secondary efficacy end point was the change in the HAM-D and Cornell scores. Results of patients on vortioxetine were compared to the results of the control group. All enrolled patients also had a concomitant specific therapy (cholinesterase inhibitors or memantine) for AD. **Results:** 94 of 105 patients completed the observation. 11 patients withdrew: 9 for non compliance and 2 for adverse drug effects. Patients had a median age of 76.7 years (range 64-84) and a median education of 5.7 years (range 4-13). There were no clinically relevant differences between treatment groups in demographic or clinical characteristics at baseline (table 1). At six month vortioxetine scored better than controls on cognitive measures: MMSE (+2.91 vs +0.31), AM (+3.58 vs +0.67), CPM (+2.67 vs +1.54), Digit Span (+0.4 vs +0.2). The MMSE, AM and CPM scores for vortioxetine differed significantly from baseline ($p < 0.001$) (table 2). Statistically significant ($p=0.05$) improvement vs. controls was observed for vortioxetine on most of the patient-reported cognitive measures: the between-group difference in the MMSE total score at month 6 was +2.17, in the AM was +2.91 and in the CPM was +2.13. The Digit Span scores for both groups did not differ significantly from baseline. The between-group difference in Digit Span change showed a trend for superiority of vortioxetine therapy, but did not reach statistical significance. Vortioxetine treatment showed significantly ($p < 0.001$) greater baseline-to-endpoint reduction in both HAM-D (-7.41 versus -2.82) and Cornell (-7.70 versus -4.67) total scores compared to control group. The between-group difference in HAM-D and Cornell change reached statistical significance in favour of vortioxetine ($p=0.05$). During the 6 months treatment period, the proportions of patients with TEAEs were 28.5% (vortioxetine) and 44.2% (control group). The most commonly reported AEs (incidence $\geq 5\%$) were nausea (8.5%) and headache (8.5%) for vortioxetine; dizziness (8.5%), nausea (10%) and headache (7.1%) in the control group. No serious AEs were reported. Two patients withdrew because of side effects: one taking paroxetine (tremors) and one bupropion (aggressiveness). Clinically relevant changes over time or differences between treatment groups were not observed in clinical laboratory test results, vital signs, weight, or ECG parameters. **Conclusion:** vortioxetine (10 mg/day) had a multi-domain beneficial effect on cognitive performance, as evidenced by improvements in measures of executive function, attention/speed of processing, and memory in elderly patients with mild Alzheimer's disease and was safe and well tolerated. The study results, even if partial, suggest that vortioxetine could be a strong candidate for use in patients with Alzheimer's disease and depressive symptoms. Further studies, including large randomized controlled trials, are needed to confirm these preliminary results.

Table 1
Demographic and clinical characteristics of patients at baseline

Variable	Vortioxetine group (n= 35)	Control group (n=70)
Females, n (%)	22 (62.8)	48 (68.57)
Males, n (%)	13 (37.14)	22 (31.42)
Race, Caucasian, n (%)	35 (100)	70 (100)
Mean age, yrs (mean ± SD)	76.5 ± 4.4	76.9 ± 4.1
Mean length of education, yrs (mean ± SD)	5.9 ± 3.1	5.8 ± 3.2
APOEε4 carrier, n (%)		
No	19 (54.28)	39 (55.71)
Yes	16 (47.71)	31 (44.28)
IADL score, (mean ± SD/total)	5.3 /8 ± 2.3	5.2 /8 ± 2.4
ADL score, (mean ± SD/total)	5.6 /6 ± 1.3	5.3 /6 ± 1.5
HIS score, (mean ± SD/total)	3.4 /18 ± 1.4	3.7 /18 ± 1.1
MMSE score, (mean ± SD/total)	20.87 /30 ± 3.1	20.79 /30 ± 3.2
GDS (short form) score, (mean ± SD/total)	8.82 /15 ± 2.4	8.61 /15 ± 2.6

Table 2
Change from baseline in rating scales score

Variable	baseline	Six month	Difference (6 months/ baseline)	P value
HAM-D				
Vortioxetine group	13.94	6.53	- 7.41	<0.001
Control group	13.51	9.69	- 2.82	0.029
CORNELL SCALE				
Vortioxetine group	13.82	6.12	- 7.70	<0.001
Control group	13.97	9.30	- 4.67	<0.001
COLOURED PROGRESSIVE MATRICES				
Vortioxetine group	11.65	15.32	3.67	<0.001
Control group	11.32	12.87	1.54	0.924
ATTENTIVE MATRICES				
Vortioxetine group	25.74	29.32	3.58	<0.001
Control group	25.94	26.61	0.67	0.879
DIGIT SPAN				
Vortioxetine group	3.4	3.8	0.4	0.846
Control group	3.4	3.6	0.2	0.849
MMSE				
Vortioxetine group	20.87	23.78	2.91	<0.001
Control group	20.79	21.10	0.31	0.789

P12: CRITICAL PATH FOR ALZHEIMER'S DISEASE (CPAD) CONSORTIUM'S VISION FOR AN AGGREGATED, STANDARDIZED, AND ACTIONABLE GLOBAL ALZHEIMER DISEASE CLINICAL TRIAL DATABASE.

Volker D. Kern¹, Stephen P. Arneric¹, Maria C. Carrillo², James Hendrix², Billy Dunn³, Stacie Weninger⁴, Jeffrey A. Kaye⁵, Daniel R. Karlin⁶, Lisa H. Gold⁷, Michael Gold⁸, Samantha Budd Haerberlein⁹, Molly Shea¹⁰, George Vradenburg¹¹, Daniela J. Conrado¹, Klaus Romero¹ ((1) *Critical Path for Alzheimer's Disease Consortium, Critical Path Institute, Tucson, AZ, USA*; (2) *Alzheimer's Association, Chicago, IL, USA*; (3) *Food and Drug Administration, Silver Spring, MD, USA* (4) *F-Prime Biomedical Research Initiative, Cambridge, MA, USA*; (5) *Oregon Health & Science University, Portland, OR, USA*; (6) *Pfizer, Boston, MA, USA*; (7) *Merck & Co., Inc., Kenilworth, NJ, USA*; (8) *AbbVie, North Chicago, IL, USA*; (9) *Biogen, Cambridge, MA, USA*; (10) *Novartis Pharmaceuticals Corporation, East Hanover, NJ, USA*; (11) *UsAgainstAlzheimer's, Washington, DC, USA*)

Background: Integrated and standardized clinical research data can catalyze biomedical discoveries and optimize clinical drug development. In 2011, the Critical Path for Alzheimer's Disease (CPAD) consortium (formerly the Coalition Against Major Diseases) developed the first publicly-available Alzheimer disease (AD) database of CDISC-standardized clinical trial data (Critical Path Institute Online Data Repository, CODR [1]). Because submissions to regulatory agencies of data from pivotal trials or accepted drug development tools are required to be in CDISC standards, there remains a need to create a standardized environment for this evolving AD database. More recently, the Global Alzheimer's Association Integrated Network (GAAIN; [2]), funded by the Alzheimer's Association, facilitated the creation of a portal enabling the sharing of key metadata (derived from 500,000 subjects), enabling qualified researchers to apply for access to individual AD databases across 34 study repositories (as of May 2018). Individual databases, many of them linked to the GAAIN portal, are being hosted by organizations such as the National Alzheimer's Coordinating Center (NACC; [3]), the Dementias Platform UK (4), the National Institute on Aging Genetics of Alzheimer's Disease Data Storage Site (NIAGADS; [5]), the National Cell Repository for Alzheimer's Disease (NCRAD; [6]), the Oregon Health & Science University Brain Institute's Layton Aging & Alzheimer's Disease Center database (7). The majority of these databases have not been curated to CDISC standards, a critical limiting step in aggregating data across different study sources and a requirement for regulatory submittal. A logical progression in the evolution of data sharing that foments integration within the community of data centers and consortia would be the creation of a fully-integrated, and actionable (CDISC standardized) Global AD Clinical Trial Database (Figure 1). Principles established by the Collaboration for Alzheimer's Prevention (CAP) will be used to guide data/sample sharing in preclinical AD trials [8]. **Objectives:** 1). Ensure that studies used to support our understanding of AD progression have informed consents that allow future data sharing in compliance with applicable local regulations; 2) Collect data using CDISC standards to ensure that all data can be integrated into a standardized, actionable database; 3) Reinforce CAP's data/sample sharing principles; and 4) Provide a mechanism to enable qualified researchers an "Open Science" environment for data analysis and modeling. **Methods:** With the input of CAP and strong support by the U.S. Food

and Drug Administration (FDA), CPAD has aligned around a new vision that will focus heavily on the AD prevention space, with the development of a quantitative understanding of disease progression and biomarker dynamics (especially standardized data from all biomarker dimensions of the new NIA-AA Research Framework) across the Alzheimer disease continuum. As data from newer technologies that use biometric monitoring measurements become available (e.g., medication adherence, computer use, mobility and sleep analysis) they will need to be integrated as potential metrics related to activities of daily living. **Results:** CPAD's anonymized, patient-level database consists of 24 standardized studies across all stages of the disease integrated into a single dataset of approximately 6,500 individual subjects. As of April 2018, CPAD's publicly-available, patient-level database has been utilized by 245 academic institutions; 164 pharmaceutical organizations; 68 other organizations; 32 non-profit organizations and 11 government agencies. A majority of these entities are located in North America (57%); a significant number are based in the EU (24%); a number reside within Asia (15%); and smaller numbers exist within Australia (2%), Africa (1%) and South America (1%). Four additional studies with 455 additional subjects are being remapped for integration in July 2018. A concise addendum to standard informed consent forms has been created to enable patients to share their data and samples for future research [9]. In association with Alzheimer's Association and other stakeholders, a framework is being developed to create a publicly-accessible repository of clinical data brought together in a standardized format to enable "open science" data analysis and modeling of fully-anonymized patient-level data. **Conclusion:** A Global AD Clinical Trial Database that is standardized and actionable, together with the potential to link to other observational studies and healthy aging cohorts, will allow the development of a quantitative understanding of disease progression and biomarker dynamics across the AD continuum. Quantitative medicine approaches applied to the AD continuum in an "Open Science" environment, will be a catalyst for AD research and optimize drug development. References: (1) CPAD CODR - LINK; (2) GAAIN - LINK; (3) NACC - LINK; (4) Dementias Platform UK - LINK; (5) NIAGADS - LINK; (6) NCRAD - LINK; (7) OHSU Brain Institute's Layton Aging & Alzheimer's Disease Center database - LINK; (8) Weninger S, et al. Collaboration for Alzheimer's Prevention: Principles to guide data and sample sharing in preclinical Alzheimer's disease trials. *Alzheimer's Dement.* 2016 May;12(5):631-2; (9) Hake AM, et al. Concise informed consent to increase data and biospecimen access may accelerate innovative Alzheimer's disease treatments. *Alzheimer's Dement Transl Res Clin Interv.* 2017 Nov;3(4):536-41.

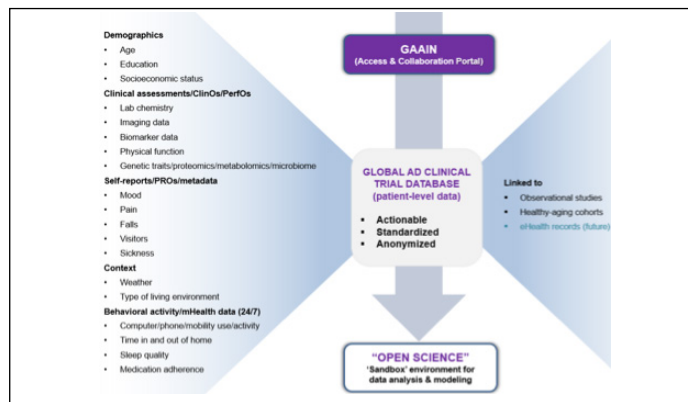

P13: EFFECTS OF BODY WEIGHT ON SAFETY OF 23MG DONEPEZIL IN ALZHEIMER'S DISEASE: A POST-HOC ANALYSIS OF A MULTICENTER, RANDOMIZED TRIAL. Yun Jeong Hong^{1,2}, Hyun Jeong Han³, Young Chul Youn⁴, Kyung Won Park⁵, Dong Won Yang⁶, Sang Yun Kim⁷, Hwa Jung Kim⁸, Ji Eun Kim⁹, Jae-Hong Lee,¹ the ODESA study group ((1) Neurology, Asan Medical Center, University of Ulsan College of Medicine, Seoul; (2) Biomedical research institute, Pusan National University Hospital, Pusan; (3) Neurology, Dementia and Neurocognitive Center, Myongji Hospital, Seonam University College of Medicine, Ilsan; (4) Neurology, Chung-Ang University Hospital, Seoul; (5) Neurology, Dong-A University College of Medicine, Busan; (6) Neurology, The Catholic University of Korea, Seoul; (7) Neurology, Seoul National University College of Medicine & Neurocognitive Behavior Center, Seoul National University Bundang Hospital, Seongnam; (8) Preventive Medicine, Asan Medical Center, University of Ulsan College of Medicine, Seoul; (9) Neurology, University of Ulsan College of Medicine, Gangneung Asan Medical Center, Gangneung, Korea)

Background: High dose of donepezil 23mg is prescribed for patients with Alzheimer's disease (AD) who showed a poor response to lower dose based on the fact that cholinergic deficits are aggravated with the disease progression and acetylcholinesterase inhibitors showed dose-related cognitive benefits. However, the adverse events (AEs) triggered by rapid increases in acetylcholine levels in the brain might reduce the patients' drug adherence. The cholinergic side effects are affected by many factors, including body weight (BW). **Objectives:** The objective of this post-hoc analysis was to evaluate the effects of body weight on the safety and tolerability of high dose donepezil. We assessed the incidence of AEs during first 12 weeks from dose escalation in patients with moderate to severe AD. **Methods:** Data from a 12-week, multicenter, randomized, open-label prospective trial named Optimal Dose Escalation Strategy to successful Achievement of high dose donepezil 23mg (ODESA) study conducted in 6 centers in Korea between December 2014 and July 2016. In the study, we included patients diagnosed as probable AD aged between 45 and 90 who were treated with donepezil 10 mg with stable dose prior to the study. The Mini-Mental State Examination score should be 20 or less and the dementia severity moderate to severe. The study duration was 12 weeks. The patients were retrospectively divided into two groups of low BW group (below 55kg) and normal BW (55kg and over) groups. We compared the incidences of AEs according to baseline BW and assessed the relationship between baseline characteristics and AEs at 12 weeks from baseline. **Results:** Among 175 enrolled, 110 patients completed the study and the other 50 patients dropped out due to AEs. Baseline demographics and clinical status except the age and gender distribution were similar among the low BW group (N=63) and normal BW group (N=96) (p>0.05). Using safety dataset (N=160), drug-discontinuation due to AEs and the incidence of all AEs showed numerical differences (more in the low BW group) although it did not reach statistical significance. Baseline BW revealed significant relationship with the occurrence of AEs during 12 weeks (p=0.022, OR=0.953), and the relationship was more prominent in the no-titration group during the first 4 weeks of dose escalation period (p=0.009, OR=0.890). However, incidences of drug discontinuation due to AEs or SAE were not different according to baseline BW. **Conclusion:** In this study, patients with low BW showed more AEs and baseline

BW was the most important factor related with the occurrence of cholinergic AEs during the first 12 weeks of high dose donepezil. Among AD patients who are considered for dose escalation to 23mg donepezil, patients with body weight may experience increased risk of cholinergic AEs. Keywords: safety, body weight, high dose donepezil, Alzheimer's disease.

Table 1

Baseline characteristics according to baseline body weight (all groups)

Variables	Low BW (<55kg) (n=63)	Normal BW (≥55kg) (n=97)	P
Age, yr	77.1±8.0	74.1±8.9	0.038
Gender, female (%)	51/63, 81%	47/97, 48.5%	<0.001
Education (low / intermediate/high, n)	39/15/9	45/26/26	0.099
Baseline MMSE	13.1±5.0	14.0±4.6	0.238
Baseline CDR	1.7±0.7	1.6±0.6	0.664
Baseline GDS	4.9±0.6	4.8±0.7	0.367
Baseline weight, kg	48.3±4.6	64.6±7.0	<0.001
Baseline BMI, kg/	21.5±2.1	25.4±2.8	<0.001
TEAE (%)	39/63 (61.9%)	62/97 (63.9%)	0.797
TEAE, severity	24/7/1(mod 25%)	41/9/0 (mod18%)	0.400
AESI (%)	30/63 (47.6%)	37/97 (38.1%)	0.235
AESI_severity	6/0/0 (mod 0%)	7/1/0(mod 1-12.5%)	0.571
AE_GI	28/63 (44.4%)	33/97 (34.0%)	0.185
AEGL_severity	22/5/1 (mod≥ 21.5%)	28/5/0(mod≥15.2%)	0.517
Discontinuation d/t AE	23/63 (36.5%)	27/97 (27.8%)	0.248

MMSE, mini-mental state examination; CDR, clinical dementia rating; GDS, general deterioration scale; BMI, body mass index; TEAE, treatment-emergent adverse events; AESI, adverse events of special interests; AEGL, adverse events of gastrointestinal tracts; AE, adverse events

P15: A SINGLE ASCENDING DOSE STUDY TO ASSESS THE SAFETY, PHARMACOKINETICS, AND PHARMACODYNAMICS OF LY3303560, A TAU-SPECIFIC ANTIBODY, IN HEALTHY VOLUNTEERS. Stephen Lowe¹, Jeffrey Dage², Ann Cleverley³, Albert Lo², Elizabeth S. LaBell², Hakop Gevorkyan⁴, Stanford Jhee⁵, Larry Huffman², Boris Calderon², Brian A. Willis² ((1) Lilly Centre for Clinical Pharmacology, Singapore; (2) Eli Lilly and Co, Indianapolis, IN; (3) Eli Lilly and Co, Erl Wood, UK; (4) California Clinical Trials Medical Group, Inc.; (5) PAREXEL Early Phase, Glendale, CA, USA)

Background: LY3303560 (LY) is a humanized IgG4 monoclonal antibody that binds to aggregated tau from patients with Alzheimer's disease (AD) and other tauopathies. In preclinical in vitro and in vivo studies, LY reduces trans-cellular spread of tau seeds and tau pathology propagation. By binding to aggregated tau, LY is hypothesized to block or delay trans-cellular spread of aggregated tau, neurofibrillary tangles formation and neuronal loss, and may have the potential to slow the progression of tau-related diseases. This is an initial Phase I study to support further clinical development of LY. **Objectives:** This was an investigator and subject blind, randomized parallel, single ascending dose (SAD) study (NCT02754830) to assess the safety, pharmacokinetics (PK) and pharmacodynamics

after a single dose of LY in healthy volunteers. **Methods:** Healthy volunteers received either a single intravenous (IV) dose of LY or placebo or a single subcutaneous (SC) dose of LY, followed by a 3-month follow-up period. Safety was evaluated by adverse events, electrocardiograms, vital signs, clinical laboratory tests, magnetic resonance imaging (MRI) and neurological monitoring. Immunogenicity assessments were performed. Total tau in plasma was measured using a mesoscale discovery enzyme-linked immunosorbent assay. Plasma PK and total tau were assessed up to 84 days after administration of study drug. **Results:** Seventy two healthy subjects, age range 29-68 years, 69% males, entered the study. Sixty six subjects received a single IV dose of LY or placebo in 8 dose cohorts covering an 800-fold dose range. Six subjects received a single SC dose of LY. Overall, LY was well tolerated up to the highest dose tested. Based on interim data (65 subjects completed), there were no serious adverse events reported and no subjects discontinued the study because of an adverse event. No significant infusion reactions, treatment-emergent anti-drug antibodies or imaging abnormalities (detected via MRI) were observed in the interim dataset, up to the highest dose of LY. Safety data from all subjects will be presented in the poster. Following IV administration, the PK of LY appeared linear over the dose range studied. LY was eliminated in a bi-exponential manner, with a terminal half-life of approximately 2 to 3 weeks. Plasma tau data will be presented in the poster. **Conclusions:** The Phase I data generated indicates an appropriate safety and PK profile to support further investigation in clinical trials of patients with AD.

P16: CNP520, A NOVEL ORAL BACE1 INHIBITOR, HAS NO CLINICALLY MEANINGFUL EFFECT ON QTC INTERVAL UP TO SUPRATHERAPEUTIC DOSES. Stefan Viktor Vormfelde¹, Nicole Pezous¹, Gilbert Lefevre¹, Carine Kolly¹, Ulf Neumann¹, Pierre Jordaan², Guenter Heimann², Mike Ufer¹, Ana Graf², Eric Legangneux¹ ((1) Novartis Institutes for BioMedical Research, Basel, Switzerland; (2) Novartis Pharma AG, Basel, Switzerland)

Background: CNP520 is a BACE inhibitor currently studied in the Generation Program in cognitively unimpaired subjects at risk to develop symptoms of Alzheimer's disease. In the two clinical studies CNP520 is orally administered once daily at doses of 15 mg and 50 mg. In vitro, CNP520 inhibited the human Ether-á-go-go-Related-Gene (hERG) channel with a half-maximal inhibitory concentration (IC₅₀) of 3.2 μM and has no relevant inhibitory effects on hNav^o1.5 and hCav 1.2 cardiac channels. No effects of CNP520 were observed on the ECG or the cardiovascular system in dogs in vivo in preclinical safety studies up to the maximum doses tested. This is in agreement with the C_{max} of unbound CNP520 in dog plasma, which reached 0.49 μM at the highest single dose of 200 mg/kg. For the 50 mg dose under development in humans, a free plasma concentration of 0.028 μM is anticipated at steady state, thus 114-fold below the in vitro IC₅₀ at the hERG channel. **Objectives:** The objective of this analysis was to explore any potential effect of CNP520 on the ECG with the primary focus on QTcF. The analysis was performed in accordance with the 2015 ICH E14 guidance for the definitive assessment of a potential drug effect on cardiac repolarization. **Methods:** Effects of CNP520 on QTc intervals were examined in three studies in healthy, mostly elderly subjects aged 60 years or above. In the first-in-human study, a total of 204 subjects received up

to 1125 mg CNP520 as single doses or up to 300 mg for 14 days. In a 3-months safety and tolerability study, a total of 124 subjects received up to 85 mg for 13 weeks. In a Japanese ethnic sensitivity study, a total of 44 subjects received up to 750 mg CNP520 as single doses or 85 mg for 14 days, respectively. ECG data were derived from standard triplicate 12-lead ECGs or continuous ECG monitoring ("Holter"). Changes from the mean baseline (δ) of the following ECG parameters were analyzed: δ QTcF, δ QT, δ HR, δ PR, and δ QRS. Analyses included central tendency analysis, concentration-response analysis and categorical outlier analysis according to FDA and ICH E14 guidances. **Results:** No clinically relevant effects were observed, neither on QTcF nor on the ECG parameters heart rate, PR interval and QRS duration in the CNP520-treated subjects. On concentration-effect modelling, the upper limit of the 90% confidence interval of the δ QTcF concentration-effect response did not reach the 10 ms threshold up to the highest mean concentration (resulting from 300 mg over 14 days). No clinically relevant effect on δ QTcF was detected on the first day of CNP520. No clinically relevant effect was detected in any of the predefined subgroups stratified by sex, age or ethnicity, on dedicated analyses. No clinically relevant difference was seen on categorical analysis. **Conclusions:** CNP520 was devoid of any clinically relevant effect on QTcF or any other ECG parameter at single doses up to 1125 mg, at 14 days up to 300 mg and at 13 weeks up to 85 mg. This finding, along with other non-clinical and clinical safety data, supports the excellent cardiac safety profile of CNP520 and its use in cognitively unimpaired subjects at risk to develop symptoms of Alzheimer's disease as in the Generation Program.

P18: DIFFERENCES IN TREATMENT RESPONSE BETWEEN MALES AND FEMALES WITH MILD-MODERATE ALZHEIMER DISEASE BEING TREATED WITH CHOLINESTERASE INHIBITORS. Kenneth Rockwood^{1,2}, Justin Stanley¹, Susan E Howlett^{1,2,3} ((1) DGI Clinical Inc., Halifax, NS, Canada; (2) Division of Geriatric Medicine, Dalhousie University, Halifax, NS Canada; (3) Department of Pharmacology, Dalhousie University, Halifax, NS, Canada)

Background: Cholinesterase inhibitors, such as galantamine, remain the most common drug class used to treat Alzheimer disease (AD). Placebo-controlled trials have demonstrated benefit in cognitive function and global assessments change. Even so, whether sex differences influence the effectiveness or tolerability of the drug is little explored. Here, we compared measures of cognitive function, patient/carer and clinician rated goal attainment, global assessment of change, daily function, caregiver burden, and drug related adverse events between males and females being treated with galantamine in an AD clinical trial. **Objectives:** Our objectives were to: 1) compare the response to cholinesterase inhibitor treatment in males and females through primary and secondary outcome measures, and 2) determine whether a relationship between drug related adverse events and sex is present. **Methods:** This is an exploratory analysis of the Video-Imaging Synthesis of Treating Alzheimer's disease (VISTA) study, a Canadian four-month double-blinded, placebo-controlled trial of galantamine followed by a four-month open label extension [1]. Baseline disease severity was assessed with the Mini-Mental State Examination scores with scores between 20-25 (inclusive) staged mild and scores between 10-19 staged moderate. To investigate difference in treatment effects, we considered

only individuals who received treatment for the entire eight-month period. The primary outcome was Goal Attainment Scaling (GAS) measured at four months. Secondary outcome measures were Alzheimer's Disease Assessment Scale-Cognitive subscale (ADAS-Cog), Clinician's Interview-Based Impression of Change-Plus caregiver input (CIBIC-Plus), Disability Assessment for Dementia (DAD), and Caregiver Burden Scale scores (CBS). Change scores were determined as the difference from baseline. Objectives were evaluated using between-group Standardized Response Means (SRM) by sex (objective 1), with odds ratios (OR) to evaluate whether females were more likely to experience drug related adverse events (objective 2). **Results:** Males (N=23) and females (N=41), from the VISTA treatment arm, had similar baseline characteristics. On average, these individuals were older adults (76.3±7.6 years old) with ADAS-Cog (24.1±6.0) and Clinician's Interview-Based Impression of Severity scores (3.4±0.7) consistent with mild-moderate AD. At four months, a significant difference was seen in clinician-rated GAS between the sexes, with males outperforming females (absolute difference between groups 5.9, SRM=0.62, p=0.021), but not in patient-rated GAS (2.6, SRM=0.24, p=0.389). These relationships were also shown in the total population between treatment arms, in favour of galantamine (clinician-rated GAS: 4.0, SRM=0.41, p=0.02; patient-rated GAS: 1.9, SRM=0.20, p=0.27) [1]. For secondary outcome measures, males performed significantly better on DAD scores (6.9, SRM=0.58, p=0.026) and slightly better across other measures (ADAS-cog -2.2, SRM=-0.38, p=0.147; CIBIC-Plus -0.6, SRM=-0.53, p=0.052) but not in CBS (1.1, SRM=0.24, p=0.434). In the VISTA treatment arm, males were more likely (OR 3.01, 95% CI 0.31-150) to experience at least one adverse event. Females were more likely to experience at least one drug related adverse event (2.70, 0.81-9.60). Neither of these ORs were statistically significant. **Conclusions:** By four months, male subjects performed slightly better than women across all outcome measures except in caregiver burden. Significant differences, in favour of males, were seen in the primary outcome measure (GAS) and in measures of daily function. Men and women appeared to experience comparable drug related adverse events, although the power was inadequate to detect important differences. 1. Rockwood, K., et al. (2006). Attainment of treatment goals by people with Alzheimer's disease receiving galantamine: a randomized controlled trial. *CMAJ*, 174(8): 1099-1105.

P36: PHASE 1 CLINICAL STUDIES IN ALZHEIMER'S DISEASE: CEREBROSPINAL FLUID OLIGOMER CHANGE AND OTHER EXPLORATORY OUTCOMES OF AMYLOID B AGGREGATE-SPECIFIC ANTIBODY KHK6640. Marc Cantillon, MD¹, Hiroyuki Shimada², Kenichiro Sugiyama³, Wei Sun¹, Yoshiumi Ouchi³, Katsuyoshi Tsukii¹, Gemma Clark⁴ ((1) Kyowa Kirin Pharmaceutical Development, Inc., USA; (2) Osaka city university hospital, Osaka, Japan; (3) Kyowa Hakko Kirin Co., Ltd., Japan; (4) Kyowa Kirin International plc, UK)

Background: KHK6640 is a novel humanized anti- amyloid β (A β) aggregates specific IgG4-based monoclonal antibody. KHK6640 and/or the mouse parent antibody showed high potency in improvement of cognitive impairment in several rodent Alzheimer's disease (AD) models including human A β -injection mice model or APPxPS2 transgenic mice. KHK6640 also showed favorable safety and pharmacokinetic profiles in preclinical studies, warranting clinical studies in human. Three phase 1 studies of KHK6640 were conducted to assess the

safety, pharmacokinetics (PK), and exploratory objectives in Caucasian patients and Japanese patients with prodromal, and mild to moderate AD. **Methods:** Three phase 1 clinical studies have been completed with KHK6640 for the treatment of AD. One (6640-001) was conducted in Europe (NCT02127476). It was a single and multiple ascending dose (SAD and MAD), randomized, double-blind, placebo-controlled clinical study in subjects with prodromal, or mild to moderate AD. Subjects were administered single and multiple (at 28-day intervals) ascending doses of KHK6640 (iv infusion: 1, 3, 10, or 20 mg/kg or placebo; sc injection: 0.3 mg/kg or placebo) for up to 6 times. The other two studies (6640-002: NCT02377713 and 6640-003: NCT03093519) were conducted in Japan. 6640-002 was a SAD, randomized, double-blind, placebo-controlled clinical study in subjects with mild to moderate AD. Subjects were administered single ascending doses of study drug (KHK6640 iv infusion: 1, 3, 10, or 20 mg/kg or placebo). In 6640-003, mild to moderate AD subjects were administered multiple (at 28-day intervals) times of study drug (KHK6640 iv infusion: 20 mg/kg or placebo) for up to 5 times. Safety measurements include incidence of treatment-emergent adverse events (TEAEs), vital signs, physical examinations, laboratory values, 12-lead electrocardiogram and brain magnetic resonance imaging (MRI) at routine visit. The PK and immunogenicity of KHK6640 were investigated as well as biomarkers including amyloid and tau. Exploratory clinical efficacy, cerebrospinal fluid (CSF) biomarkers, fluorodeoxyglucose positron emission tomography (PET) signal and amyloid PET signal of KHK6640 were also investigated. **Results:** A total of 85 unique subjects received a single/multiple doses of KHK6640. In SAD, MAD phase of 6640-001, 6640-002, and 6640-003, 38, 40, 16, and 6 subjects were randomized to receive KHK6640, while 8, 11, 4, and 2 subjects were randomized to receive placebo, respectively. Two subjects discontinued study drug due to treatment unrelated serious AEs (10 mg/kg, MAD phase; traffic accident, and Placebo, SAD phase; pancreatic mass) in 6640-001. Two subjects experienced a treatment related serious AE (6640-001 1 mg/kg, MAD phase; hypotension, 90/60 mmHg, and 6640-002 10 mg/kg; lacunar infarction which was confounded by elder age and medical history of hypertension). KHK6640 was overall well tolerated and there was no death due to TEAEs in these studies. No amyloid-related imaging abnormalities-edema (ARIA-E) was reported and only 7 subjects had microhemorrhages which identified from MRI. Only one case of non-serious infusion related reaction was reported from all treated patients. Pharmacokinetics of KHK6640 were linear from 1 and 20 mg/kg. Following multiple iv infusion of KHK6640 20 mg/kg, the mean value of elimination half-life ($t_{1/2}$) was approximately 18 days. Six of 60 subjects who received KHK6640 were positive for anti-KHK6640 antibodies (ADA) at some points after drug administration. Of the 11 biomarkers analyzed in CSF from subjects in the MAD phase of 6640-001, bound oligomer in CSF showed a clear dose-dependent increasing trend in response to KHK6640. There were no significant ethnic differences between Caucasians and Japanese subjects in Safety and PK or efficacy outcomes. **Conclusions:** Safety results support KHK6640 tolerability after SAD/MAD iv up to 20 mg/kg. A first in human AD study demonstrated dose-related CSF oligomer changes. Thus specific KHK6640 target engagement was replicated from preclinical data, with good safety/tolerability and consistent PK across Caucasian and Japanese AD patients.

P80: CUMULATIVE ADUCANUMAB SAFETY DATA FROM PRIME: A RANDOMIZED, DOUBLE-BLIND, PLACEBO-CONTROLLED, PHASE 1B STUDY. Philipp von Rosenstiel¹, Tianle Chen¹, John O’Gorman¹, Min Yee¹, Carmen Castrillo-Viguera¹, Claudia Prada¹, Christoph Hock², Roger M Nitsch², Samantha Budd Haeberlein¹, Alfred Sandrock¹ ((1) Biogen, Cambridge, MA, USA; (2) Neurimmune, Schlieren-Zurich, and University of Zurich, Switzerland)

Background: PRIME is an ongoing Phase 1b study evaluating the safety, tolerability, pharmacokinetics, and pharmacodynamics of aducanumab in patients with prodromal or mild Alzheimer’s disease (AD). In previously presented interim analyses of PRIME, patients treated with aducanumab experienced dose- and time-dependent decreases in amyloid plaque levels accompanied by slowed clinical decline. Amyloid-related imaging abnormalities (ARIA), including ARIA-E (ARIA with vasogenic edema) and ARIA-H (ARIA with microhemorrhage, macrohemorrhage, or superficial siderosis), are imaging findings measured by MRI that have been associated with anti-amyloid beta ($A\beta$)-lowering therapies and, in this study, are reported as adverse events. Here, we report integrated ARIA safety data from the PRIME placebo-controlled period and long-term extension (LTE) as of the last interim data analysis. **Methods:** Patients included in PRIME (NCT01677572) were aged 50–90 years, had a positive florbetapir positron emission tomography (PET) scan, and met clinical criteria for prodromal or mild AD. During the 12-month placebo controlled period, patients were randomized to receive placebo or fixed doses of aducanumab (1, 3, 6, or 10 mg/kg), stratified by ApoE ϵ 4 status, once every 4 weeks for 52 weeks. A protocol amendment added a cohort of ApoE ϵ 4 carriers receiving aducanumab titrated to 10 mg/kg (2 doses of 1 mg/kg, 4 doses of 3 mg/kg, 5 doses of 6 mg/kg, and 10 mg/kg thereafter) or placebo to explore the impact of titration on ARIA incidence. Patients meeting eligibility criteria at Week 56 were enrolled in the LTE, where all patients were assigned to receive aducanumab 3, 6, or 10 mg/kg, fixed or titrated. The primary endpoint for both the PRIME placebo-controlled period and LTE was safety. **Results:** Since the start of the PRIME study, ARIA-E (with or without ARIA-H) has been observed in 46 of the 185 patients dosed with aducanumab, with an overall incidence of 25%. Of the 46 patients who had ARIA-E, 30 (65%) were asymptomatic. Regarding clinical symptomatology, 35% of patients with ARIA-E, including patients with ARIA-E and ARIA-H, had associated symptoms. Symptoms were typically mild and transient and included headache, dizziness, visual field disturbances, nausea, and vomiting. Four patients had severe symptoms, which included seizure and cardiac arrest ($n = 1$), headache ($n = 1$), migraine ($n = 1$), and delirium ($n = 1$). ARIA E resolved on MRI in 44 of 46 patients and was ongoing in 2 patients at the time of study withdrawal. In most cases, ARIA-E resolved 4 to 12 weeks after onset, as assessed by MRI, and ARIA-H typically stabilized 2-4 weeks after onset. Most patients with ARIA-E continued treatment. Recurrent ARIA-E events were observed in 6 patients. Recurrent ARIA-E was similar to initial events in regard to severity, symptoms, and time to resolution. During the placebo-controlled period, the incidence of ARIA-E in fixed-dose cohorts was dose dependent. ARIA-E occurred in 0%, 3%, 6%, 37%, and 41% of patients receiving placebo, 1, 3, 6, or 10 mg/kg aducanumab in the placebo-controlled period, respectively. ARIA-E also appeared to be ApoE ϵ 4 carrier-dependent. Although sample

sizes were small, incidence of ARIA-E during the placebo-controlled period was lower in ApoE ϵ 4 carriers receiving titration to 10 mg/kg (35%) than in ApoE- ϵ 4 carriers receiving higher fixed-dose administration of 6 mg/kg (43%) or 10 mg/kg (55%). Incidence of ARIA-H not accompanied by ARIA-E in the placebo-controlled period was low and similar across all dose groups (including placebo, fixed-dose, and titration arms). During the LTE, incidence of ARIA-E was observed in patients newly exposed to aducanumab after switching from placebo to aducanumab (22%) and in patients who switched from 1 to 3 mg/kg (18%), which was consistent with the incidence observed in the placebo-controlled period for active arms. For those participants continuing on their initially assigned dose of aducanumab during the LTE, ARIA-E incidence was 0%, 0%, 5%, and 17% in patients from the 3 mg/kg, 6 mg/kg, 10 mg/kg and titration cohorts, respectively. Incidence of ARIA-H not accompanied by ARIA-E in the LTE was 7%. **Conclusions:** Incident ARIA-E appeared to be dose dependent and to occur more frequently in ApoE ϵ 4 carriers. However, incidence of ARIA-E appeared lower in ApoE ϵ 4 carriers receiving titration to 10 mg/kg compared with carriers receiving fixed-dose regimens of 6 mg/kg or 10 mg/kg. Recurrent ARIA events were consistent with other ARIA events reported to date in the PRIME study. The majority of ARIA events occurred early in the course of treatment; they were typically mild, asymptomatic, and resolved or stabilized within 4-12 weeks, with most patients continuing treatment.

P109: THE ACTION FOR HEALTH IN DIABETES CLINICAL TRIAL: DOES A 10-YEAR INTENSIVE MULTIDOMAIN LIFESTYLE INTERVENTION PROVIDE COGNITIVE BENEFITS? Kathleen M. Hayden¹, José A. Luchsinger², Stephen R. Rapp¹, Delilah R. Cook¹, Rebecca H. Neiberg¹, Judy L. Bahnson¹, Tara D. Beckner¹, Jerry M. Barnes¹, Mark A. Espeland¹, for the Look AHEAD MIND Study Group ((1) Wake Forest School of Medicine, Winston-Salem, USA; (2) Columbia University, New York, USA)

Background: Intensive lifestyle interventions to decrease caloric intake, improve diet, increase physical activity, and manage risk factors, when delivered in mid-life to a cohort at increased risk for cognitive decline due to overweight/obesity and type 2 diabetes, may be expected to provide cognitive benefits, however this remains unproven. **Objectives:** We present results emerging from the Action for Health in Diabetes (Look AHEAD) randomized controlled clinical trial on cognitive and brain MRI outcomes that motivate extended follow-up of this cohort to understand the potential benefits and harms of long-term multi-domain lifestyle interventions on the brain health of a cohort at elevated risk for cognitive decline due to type 2 diabetes and mid-life obesity. **Methods:** The Look AHEAD) trial enrolled 5,145 women and men, aged 45-76 years, with body mass index (BMI) >25 kg/m² and type 2 diabetes. Participants were randomly assigned with equal probability to 10 years of Intensive Lifestyle Intervention (ILI) or Diabetes Support and Education (DSE). The multidomain ILI included diet modification and physical activity designed to induce weight loss to average $>7\%$ at one year and maintain this over time. ILI participants were assigned a daily calorie goal (1200-1800 based on initial weight), with $<30\%$ of total calories from fat ($<10\%$ from saturated fat) and $>15\%$ from protein. The physical activity goal was >175 min/week through activities similar in intensity to brisk

walking. DSE participants were invited (but not required) to attend three group sessions each year, which focused on diet, physical activity, and social support. These individuals did not receive specific diet, activity, or weight goals or information on behavioral strategies. Participants in both interventions were provided feedback on cardiovascular risk factors levels and guidelines about risk factor management. Standardized cognitive function assessments, administered by certified staff masked to intervention assignment, began at years 8-10 of follow-up in subsets of participants enrolled in two ancillary studies and were conducted once in the full cohort during years 10-13. Adjudication of cognitive impairment (mild cognitive impairment or dementia) was based on these final assessments. Structural and functional brain MRIs were collected in 319 participants during years 10-12. **Results:** The ILI intervention resulted in a mean relative reduction of weight of over 8% at one year and a difference in weight loss from the DSE group that continues through 14 years of follow-up, even as both groups begin to lose weight with increasing age. Throughout follow-up, many risk factors for cognitive deficits were improved in the ILI group compared with DSE, including blood pressure, diabetes control, depression symptoms, and physical activity. Random assignment to 10 years of ILI provided no overall cognitive benefit across the full cohort for cognitive test scores or adjudicated cognitive impairment. However, the trial provided convergent evidence that the multidomain ILI yielded cognitive benefit for composite cognitive function (interaction $p=0.008$) and reduced the prevalence of cognitive impairment (odds ratio [95 % CI]=0.70 [0.40,1.22]) among individuals who were not obese (i.e. BMI <30 kg/m²) at baseline, while resulting in a relative cognitive deficit and increase in the prevalence of cognitive impairment (odds ratio=1.46 [0.83,2.56], interaction $p=0.03$) among individuals with Class 3 obesity at baseline (BMI >40 kg/m²). In these heaviest individuals, those with pre-existing cardiovascular disease appeared to be at greatest risk for cognitive deficits associated with the ILI. Overall, the ILI was associated with relatively greater mean ventricle volumes and cerebral blood flow and smaller ischemic lesion volumes, regardless of baseline BMI. Longer follow-up and additional cognitive testing and adjudication is necessary to confirm these findings and to examine how interventions may influence cognition later in life. Biomarker studies of inflammatory markers and hormone levels over the course of follow-up are important for understanding underlying mechanisms. The Look AHEAD MIND study is currently underway to provide these data. It seeks to continue cognitive follow-up in over 3,000 of the remaining Look AHEAD participants and assay biospecimens collected throughout the trial. **Conclusions:** Look AHEAD MIND is designed to determine whether 10 years of successful lifestyle intervention has discordant effects on late life cognitive function depending on one's initial weight. If so, this has important implications for the treatment of obesity and diabetes in older adults.

Figure 1
Mean Percent Weight Loss From Baseline By

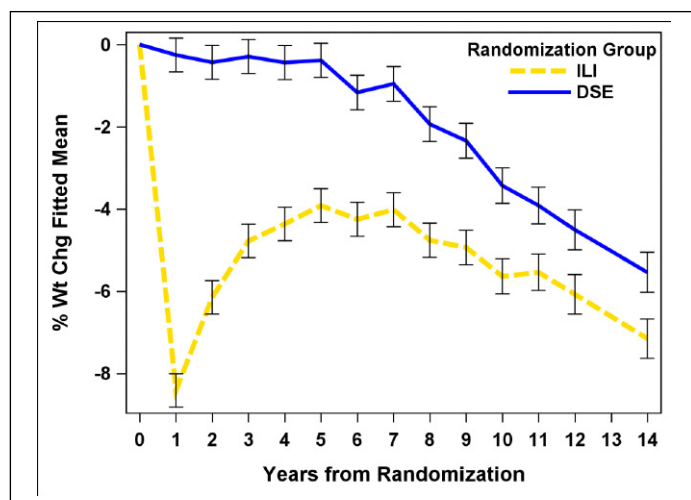
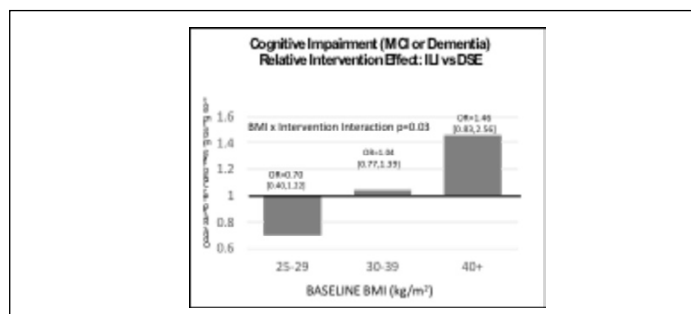

Figure 2



P110: SINGLE AND MULTIPLE DOSE SAFETY, TOLERABILITY AND PHARMACOKINETICS OF THE SELECTIVE M1 RECEPTOR PARTIAL AGONIST HTL0018318 IN HEALTHY VOLUNTEERS. Tim Tasker¹, Jan Liptrot¹, Charlotte Bakker², Ellen 't Hart², Erica Klaassen², Samantha Prins², Thalia van der Doef², Mike Walker², Giles A. Brown¹, Alastair Brown¹, Miles Congreve¹, Malcolm Weir¹, Fiona H. Marshall¹, David M. Cross⁴, Geert Jan Groeneveld², Pradeep. J. Nathan^{1,3} ((1) Sosei Heptares, Cambridge UK; (2) Centre for Human Drug Research (CDHR), Leiden, Netherlands; (3) Department of Psychiatry, University of Cambridge, UK; (4) Cross Pharma Consulting Limited, Cambridge, UK)

Background: The cholinergic neurons of the basal forebrain and medial septum provide the major source of cholinergic innervation to the neocortex and hippocampus and play a critical role modulating cognitive processes such as attention, learning and memory, in part through activation of post-synaptic M1 receptors. It is widely accepted that Alzheimer's disease (AD) is associated with significant early and progressive loss of cholinergic neurons. Cholinesterase inhibitors including donepezil have modest efficacy, potentially because they target degenerating pre-synaptic cholinergic neurons. An alternative and potentially more effective strategy is to target post-synaptic M1 receptors which are relatively preserved in AD. Muscarinic receptor agonists including the M1/M4 agonist xanomeline and the M1 orthosteric agonist GSK1034702 have shown promising early clinical effects but were not further developed due to gastrointestinal and cardiovascular

adverse events (AEs). HTL0018318 is a selective M1 agonist currently under development for the symptomatic treatment of cognitive impairment in dementias including AD and Lewy Body Dementia (LBD). **Objectives:** To examine the single and multiple dose safety, tolerability, pharmacokinetics of HTL0018318 in healthy younger adult and elderly subjects. Pharmacodynamic biomarkers were also assessed but are not presented here. **Methods:** The single ascending dose (SAD) study was a single centre, randomized, double-blind, placebo-controlled, sequential, single ascending oral (solution) dose study. HTL0018318 was administered in 5 cohorts of 8 healthy younger adult subjects in ascending dose levels of 1mg, 3mg, 9mg, 20mg and 35mg and elderly subjects in ascending dose levels of 9mg, 15mg, 23mg, 30mg and 35mg. Effect of food and CSF pharmacokinetics were examined following the 20mg dose. The multiple ascending dose (MAD) study was a single centre, randomised, double-blind, placebo-controlled, sequential, multiple ascending oral (solution) dose study. HTL0018318 was administered in 3 cohorts of 12 healthy younger adult subjects dosed at 15mg/day, 20mg/day and 25mg/day once daily for 10 days, and 3 cohorts of 12 healthy elderly subjects dosed at 15mg/day, 20mg/day and 25mg/day once daily for 10 days. One elderly cohort was dosed at 35mg using a titration regimen (5 days on 20mg/day and 10 days on 35mg/day). **Results:** Pharmacokinetics of HTL0018318 were well-characterized in all subjects at all single doses. Exposure in terms of C_{max} and AUC was dose-proportional. Absorption was rapid with a typical T_{max} of 1.0-1.5h post-dose and an apparent mean half-life of 12-16h. HTL0018318 was found to distribute into CSF (CSF:plasma ratio≈30%). There was no food effect on AUC or half-life of HTL0018318. Single doses of HTL0018318 were associated with mild dose-related AEs (with low incidence) in both younger and elderly subjects. The most frequently reported cholinergic AEs included hypersalivation, hyperhidrosis and increases in blood pressure, particularly following the 35mg dose (younger adult) and 23mg and 35mg doses (elderly). In younger adult subjects, doses up to 20mg were not associated with changes in systolic and diastolic blood pressure and heart rate. However, the 35mg dose was associated with an increase in mean systolic and diastolic blood pressure (up to 10mmHg) and mean heart rate (up to 9.8bpm). In elderly subjects, significant increases in mean systolic and diastolic blood pressure (up to 11.9mmHg) and mean heart rate (up to 6.3bpm) were observed in the 15-35mg dose range, with no clear evidence of dose-dependency. Pharmacokinetics of HTL0018318 were well-characterized in all subjects after multiple doses (Figure 1). The Inter-individual variability in exposure was moderate (6-46 %CV covering C_{max} and AUC_{0-24h}). HTL0018318 in repeated administration up to 35 mg/day for 10 days was generally well-tolerated, with mild AEs (with low incidence) and some evidence for dose-dependency. The most frequently reported cholinergic AEs included hyperhidrosis, chills, cold sweat, headache, somnolence and nausea, particularly following the 25mg dose (young adult) and 25 and 35mg doses (elderly). Repeated administration HTL0018318 over 10 days was associated with some small statistically significant increases in blood pressure on day 1 (up to 8.7mmHg) compared to placebo with a decline in this difference with continued dosing. There were no consistent or clear dose-response relationships. HTL0018318 caused small increases in mean heart rate (up to 10bpm), although these increases were in the context of overall decreases in mean heart rate (i.e. smaller decreases with HTL0018318 relative to the placebo decrease). There were

no clinically significant observations or changes in blood and urine laboratory values or abnormalities in the ECGs and Holter assessments following both single and multiple ascending doses up to 35mg. **Conclusions:** HTL0018318 showed well characterised pharmacokinetics and following single and multiple doses over 10 days were generally well tolerated in the dose range studied. The initial increase in blood pressure following single doses tended to decline with repeated dosing while increases in heart rate were small relative to baseline. These findings provide encouraging safety and pharmacokinetic data in support of the development of HTL0018318 as a symptomatic treatment for cognitive impairment in Dementia.

Figure 1

HTL0018318 arithmetic mean (\pm standard deviation) plasma concentration against time after dose following the tenth of 10 daily oral doses of 15, 20, 25 or 35 mg for elderly subjects

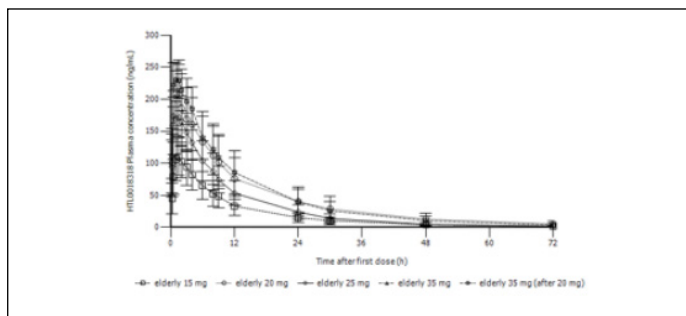

P111: ASSESSING THE PSYCHOLOGICAL AND EMOTIONAL IMPACT OF APOE AND AMYLOID DISCLOSURE IN THE API GENERATION PROGRAM: INTERIM FINDINGS. Jessica B. Langbaum¹, Jason Karlawish², Scott Roberts³, Angela Bradbury², Scott Kim⁴, Elisabeth McCarty Wood², Carolyn Langlois¹, Fonda Liu⁵, Marie-Emmanuelle⁶, Marie-Laure Rouzade-Dominguez⁶, Angelika Caputo⁶, Mauritz Bezuidenhout⁶, Cristina Lopez-Lopez⁶, Ana Graf⁶, Pierre N. Tariot¹, Eric M. Reiman¹ ((1) Banner Alzheimer's Institute, Phoenix, USA; (2) University of Pennsylvania, Philadelphia, USA; (3) University of Michigan, Ann Arbor, USA; (4) National Institutes of Health, Bethesda, USA; (5) Novartis Pharmaceuticals Corporation, East Hanover, USA; (6) Novartis Pharma AG, Basel – Switzerland)

Background: The Alzheimer's Prevention Initiative (API) is a collaborative funded by the NIH, philanthropy, and industry to conduct preclinical Alzheimer's disease (AD) trials in people who, based on age, genetics, and in some cases biomarkers, are at elevated risk for developing AD symptoms. The API Generation Program consists of two trials, Generation Study 1 and Generation Study 2, and is evaluating whether amyloid-based treatments can delay the onset and progression of clinical symptoms associated with AD. Generation Study 1 is recruiting cognitively unimpaired persons who are APOE4 homozygotes ages 60-75; Generation Study 2 is recruiting cognitively unimpaired APOE4 carriers (homozygotes and heterozygotes, heterozygotes must also have elevated brain amyloid). Participants learn their APOE genotype and, in Generation Study 2 only, amyloid results, to enroll in the Generation Program. While some studies have reported favorable psychosocial outcomes after APOE or amyloid disclosure, whether this is true of APOE4 homozygotes close to their estimated age of disease onset remains limited. In

addition, the Generation Program studies will investigate the outcome of both disclosure of APOE and brain amyloid results to participants. **Objectives:** To describe the risk disclosure program developed for the API Generation Program trials and summarize psychosocial data collected to date. **Methods:** Prior to consent, participants are offered the opportunity to watch a "pre-disclosure" educational video or review written materials about AD, APOE, and considerations for learning their APOE results. Participants may also read a brochure or receive information verbally from study staff describing the Generation Program's approach to disclosing APOE and amyloid information. Following consent, participants are assessed for psychological readiness to learn their APOE genotype. APOE genotype disclosure is either provided by trained professionals either remotely (phone or two-way real-time videoconferencing [RTVC]) with a genetic counselor, or on-site with a genetic counselor or other healthcare provider (e.g., physician) as appropriate by local law. In all cases, a standardized handout and talking points are used to guide the disclosure session. Generation Study 1 participants complete a battery of assessments to assess genetic knowledge, result recall, perceived risk, state anxiety, depression, disease-specific anxiety, satisfaction, and health behaviors at baseline, 2-7 days, 6 weeks, 6 months, and 12 months after disclosure. Generation Study 2 participants undergo an abbreviated battery of assessments at baseline and immediately following (2-7 days) APOE disclosure and again after amyloid disclosure. In the US only, some sites participate in a separate, investigator-initiated ancillary study to Generation Study 1, CONNECT 4 APOE, a multi-site randomized study to evaluate the relative short-term and longitudinal advantages of RTVC communication over telephone for communication of APOE results. Other investigator-initiated, ancillary studies are examining the impact of risk disclosure on objective and subjective cognitive functioning ("stereotype threat"; Cognition Across Time study), as well as on the shorter- and longer-term impact of APOE disclosure on participants' well-being and family relationships (the SOKRATES2 study). **Results:** As of April 30, 2018, 1,131 participants received their APOE results as part of screening for the Generation Program studies, including 337 APOE4 homozygotes, 365 heterozygotes, and 429 non-carriers; 38 participants received their amyloid results (1 APOE4 homozygote, 38 heterozygotes). Expected trends in Alzheimer's specific distress were observed in persons who learned they have an APOE4 allele. No concerns trends have been identified. Additional data will be presented as available. **Conclusions:** Interim findings suggest that disclosing APOE genotype and, in some cases amyloid results, to participants as part of screening for the Generation Program is not associated with longer-term anxiety, distress, or depression regardless of the risk associated with the actual APOE result disclosed. Ongoing data collection as part of the Generation Program and ancillary studies will help determine the effects of APOE disclosure across different modes of delivery and enhance appreciation of the psychosocial implications of high-risk results, with lessons for clinical practice and precision medicine, as well as future trials in genetically enriched populations. The results from these efforts will be crucial for developing more scalable models to communicate and disclose AD risk information to cognitively normal individuals as part of screening and enrollment efforts for preclinical AD trials.

P112: META-ANALYSIS OF TWO TAU AGGREGATION INHIBITOR PHASE 3 TRIALS IN MILD ALZHEIMER'S DISEASE WITH LOW DOSE HYDROMETHYLTHIONINE.

Bjoern Schelker^{1,2}, Claude Wischik^{1,2} ((1) *Institute for Complex Systems and Mathematical Biology, University of Aberdeen, Aberdeen, UK*; (2) *TauRx Therapeutics, Aberdeen, UK*)

Background: There is currently no disease-modifying treatment for Alzheimer's disease (AD) despite intensive efforts over a long period focussed on the A β pathway in large clinical trials. Targeting tau aggregation pathology, which is closely linked to clinical decline in early AD, offers an attractive therapeutic alternative as a disease modifying treatment. Hydromethylthionine mesylate (USAN name), also known as leuco-methylthioninium bis(hydromethanesulphonate) ("LMTM"), delivers the active reduced form of methylthionine. It converts the core tau unit of the oligomers and filaments which accumulate in AD brain into a form which is assembly- and propagation-incompetent and works orally in transgenic mouse models of tau aggregation. LMTM has been well tolerated orally in human clinical trials in over 2,000 patients to date, has good brain penetration and does not produce ARIA. We have completed two Phase 3 trials comparing high doses of LMTM (150 – 250mg/day) with a low dose (8mg/day) intended as a mask for potential urine discolouration (1,2). These showed that LMTM might be effective as monotherapy in delaying disease progression on clinical and brain imaging endpoints, and that the high doses conferred no greater potential benefit than the 8mg/day dose. **Objectives:** We sought to confirm whether the deceleration in rate of progression of brain atrophy seen after 9 months in a within-cohort analysis of monotherapy patients pooled by dose could be replicated for patients receiving only the 8mg/day dose using data pooled from both studies to provide adequate power. Since a trial aiming to confirm the efficacy of LMTM 8mg/day as monotherapy against true placebo needs to be conducted in patients not taking standard symptomatic treatments for AD, we sought to use data from the completed trials to determine the most efficient trial design in early AD in terms of duration and size that would be consistent with new EMA and FDA regulatory guidelines. We also sought to use the population plasma PK data available from these and other trials to explore whether there existed a concentration-response relationship at 8mg/day. **Methods:** We conducted a meta-analysis of clinical, imaging and population PK data from the two completed trials examining LMTM 8mg/day as monotherapy in both within-cohort before/after analyses and between-cohort comparisons with patients receiving LMTM as add-on to existing treatments as a placebo-proxy, using analyses controlled for any effect of between-cohort severity differences on rate of progression. We have reported previously that overall decline in add-on patients is indistinguishable from that seen in the placebo arms in other studies and from untreated patients in the ADNI program in terms of cognitive decline as measured by ADAS-cog11. **Results:** There were 104 patients with mild AD (MMSE 20-26 and CDR score 0.5 or 1) receiving LMTM 8mg/day monotherapy and 420 receiving the same dose as add-on to cholinesterase-inhibitors and/or memantine. Compared with the rate of whole brain atrophy measured during the first 6 months, there was significant deceleration in atrophy rate within the same cohort after 39 weeks of treatment with LMTM 8mg/day (-3.3 ± 1.3 cm³/annum [mean \pm se], $p=0.0063$). The benefit in temporal lobe glucose uptake measured using FDG-PET could be seen

already at 26 weeks ($+0.015 \pm 0.002$ SUVR units relative to pons, $p<0.0001$). Benefits on the ADAS-cog11 (-4.4 ± 0.7 units, $p<0.0001$) and ADCS-ADL23 ($+4.2 \pm 0.9$ units, $p<0.0001$) scales needed 65 weeks to reach robust statistical significance. A newly developed composite scale based on cognitive and functional items selected from the full scales was effective at showing benefit within 9 months. Urinary discolouration at the 8mg/day dose was minimal and variable over time and between patients. **Conclusions:** A study conducted over 9 months in subjects with early AD using FDG-PET as the primary biomarker outcome and a newly developed sensitive composite cognitive/functional scale as a gated co-primary clinical outcome appears to be the most efficient design to permit confirmation of efficacy in a study population not using standard symptomatic AD treatments. Based on the putative effect sizes seen at 8mg/day as monotherapy, such a study, which is currently ongoing globally, has $>90\%$ power to confirm a treatment benefit with 150 patients in active and true placebo arms on biomarker and clinical outcomes using low-dose LMTM treatment. (1) Gauthier, S., et al., *Lancet* 2016, 388:2873-2884; (2) Wilcock, G.K. et al., *Journal of Alzheimer's Disease* 2018. 61:635-657.

Theme: Clinical trials: Imaging

P10: DIAGNOSTIC ACCURACY OF [18F]FC119S PET FOR IDENTIFYING ALZHEIMER'S DISEASE.

Byung Hyun Byun, Sang Moo Lim (*Department of Nuclear Medicine, Korea Cancer Center Hospital, Korea Institute of Radiological & Medical Sciences, Seoul, - Republic of Korea*)

Background: The newly developed 18F-labeled beta amyloid tracer, 2-[2-(N-monomethyl)aminopyridine-6-yl]-6-[(S)-3-[18F]fluoro-2-hydroxypropoxy]benzothiazole ([18F]FC119S, FutureChem in South Korea) was recently introduced. In our previous study, there was a significant linear correlation between 11C-PIB and 18F-FC119S cortical SUVR. **Objectives:** We assessed the diagnostic accuracy of [18F]FC119S PET for Alzheimer's disease (AD). **Methods:** To assess the diagnostic performance of [18F]FC119S, a total of 100 subjects-AD in 50, non-Alzheimer's dementia (NAD) in 15, and cognitive normal (CN) in 35-underwent brain [18F]FC119S PET. 18F-FC119S PET images were obtained from 30 minutes to 60 minutes after the i.v. injection of 370 MBq of 18F-FC119S. For visual analysis, positive scan was defined as the PET scan with any cortical tracer uptake equal to or higher than the uptake of white matter (Figure 1). For semi-quantitative analysis, standardized uptake value ratio (SUVR)-the ratio of cerebral cortical SUV to the cerebellar SUV-was measured on each PET dataset. **Results:** Based on visual analysis, 46 of 50 cases with AD (92%), 5 of 15 cases with NAD (33%), and 3 of 35 CN cases (9%) were read as positive scans, respectively. Therefore, visual assessment of [18F]FC119S PET yielded a sensitivity of 92% and a specificity of 84% for identifying AD. According to the semi-quantitative analysis, the mean values of SUVR were 1.22 ± 0.16 in AD, 1.05 ± 0.06 in NAD, and 1.02 ± 0.06 in CN subjects, respectively. SUVR yielded a sensitivity of 84% and specificity of 84% at the criterion of SUVR > 1.07 (Table 1). **Conclusions:** [18F]FC119S PET yields high sensitivity and specificity for identifying AD and therefore may be useful in the diagnostic algorithm of dementia.

Figure 1

Exemplary cases of 18F-FC119S PET. Positive scan (left) and negative scan (right) are shown

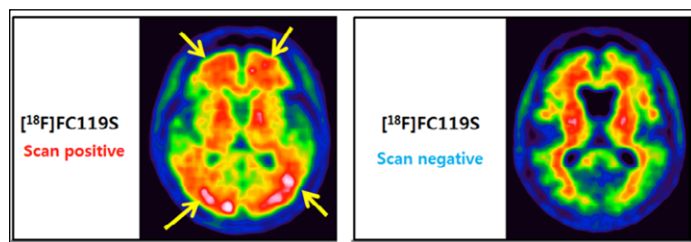
**Table 1**

Results of visual- and semi-quantitative analysis

Visual analysis	AD	NAD	CN
Positive	46	5	3
Negative	4	10	32
Semi-quantitative analysis			
SUVR, mean	1.22±0.16	1.05±0.06	1.02±0.06

AD, Alzheimer's disease; NAD, non-Alzheimer's dementia; CN, cognitive normal subjects

P35: ANNUAL ATROPHY RATE IN NORMAL AGING FROM A LARGE SINGLE-CENTER COHORT IN KOREA.

Yu Yong Choi¹, Byeong C. Kim², Seong-Min Choi², Kee Hyung Park³, Kyu Yeong Choi¹, Kun Ho Lee^{1,4} ((1) National Research Center for Dementia, Chosun University, Gwangju, South Korea; (2) Department of Neurology, Chonnam National University Hospital, Gwangju, South Korea; (3) Department of Neurology, Gachon University College of Medicine, Incheon, South Korea; (4) Department of Biomedical Science, Chosun University, Gwangju, South Korea)

Background: The study aimed to present the normative information of the aging change of brain measures such as cortical and subcortical volume, and to determine which factors, including ethnicity, sex, and education, affect the aging change estimates in normal elderly people. **Methods:** We measured cortical and subcortical volumes from anatomical MRI scans of 1,008 cognitively normal elderly Koreans aged 65 to 85 using FreeSurfer. For Caucasians, the brain images were selected from the ADNI dataset. To determine the aging rates, general linear model analyses were performed with age as the independent variable and brain measures as the dependent variable. Intracranial volume, sex, or education level were selectively added into the models as covariates when they are considered as potential confounding variables on evaluating the association between age and brain measures. **Results:** The subjects were divided into four age groups with a range of 5 years. The volume means were calculated in each age group and compared between genders. Beta coefficient estimates of age were estimated on each brain measure. The betas were significantly negative in most of brain measures. Compared to the results of Korean data, the annual change estimates of Caucasian brain volume were significantly lower, but the annual change estimates of cortical structures were not different after multiple comparison correction. Male brain volume was lower in the annual atrophy estimate. Interestingly, in female, cortical thickness of the rostral middle frontal cortex increased with age. The two factors, ethnicity and sex, affected locally some

subcortical structures and cortical regions. We confirmed that age affected on brain structures although there are the factors such as ethnicity and sex that affected globally and locally the annual changes of the brain measures. **Conclusions:** We presented the normative information on volume estimates of the brain structures of the elderly people in the subdivided age groups. This normative information of the aging brain provides the age-related reference ranges needed to facilitate research and clinical decision making such as diagnosis of neurodegenerative diseases.

P62: IMPACT OF CEREBRAL BLOOD FLOW CHANGES ON 18F-FLORBETABEN SUVR. A SIMULATION STUDY.

Santiago Bullich¹, Norman Koglin¹, Susan De Santi², Georg A. Becker³, Audrey Perroti¹, Aleksandar Jovalekic¹, Andrew Stephens¹, Henryk Barthel³, Osama Sabri³ ((1) Piramal Imaging GmbH, Berlin, Germany; (2) Piramal Pharma Inc., Boston, MA, USA; (3) Department of Nuclear Medicine, University Hospital Leipzig, Leipzig, Germany)

Background: Clinical practice uses visual assessment to classify 18F-florbetaben positron emission tomography (PET) scans as negative or positive for the presence of amyloid-beta. In the research setting, however, quantitation of amyloid-PET data is applied to monitor amyloid-beta changes both in longitudinal observational studies and in interventional trials investigating amyloid-beta-modifying treatments for Alzheimer's disease (AD). Standardized uptake value ratios (SUVRs) are widely used to assess the amyloid-beta load with PET because of their simplicity. SUVRs, however, may be biased as a surrogate marker of amyloid-beta load by cerebral blood flow (CBF). These effects may be relevant in interventional trials where an amyloid-beta-modifying drug is administered and drug effects on CBF are unknown. **Objectives:** The objective of this study was to assess the effect of CBF changes on 18F-florbetaben SUVR using three different reference regions (cerebellar gray matter (CGM), pons and subcortical white matter (SWM)). **Methods:** The study population consisted of 10 patients with mild to moderate probable AD dementia based on clinical diagnosis (69±7 y) and 10 age-matched HCs (67±8 y). Dynamic 18F-florbetaben PET scans were acquired. Arterial samples were collected after tracer injection and corrected for metabolites. Volumes of interest (VOIs) were defined on individual coregistered structural magnetic resonance images in 9 regions (CGM, pons, SWM (centrum semiovale), frontal, occipital, parietal, lateral temporal, and posterior and anterior cingulate cortices). Time-activity curves (TACs) acquired up to 140 min after injection were fitted using a two-tissue compartment model with arterial plasma input. SUVR was calculated as the ratio of the activity in the cerebral cortical regions and the activity of the reference region. Arterial input functions and rate constants (K1, k2, k3 and k4) from each subject were used to generate simulated time-activity curves. Three type of simulations considering CBF changes up to 20% were conducted: 1) regional CBF change affecting only cortical regions (i.e. K1 was changed while keeping the ratio K1/k2 constant); 2) regional CBF change affecting only the reference region (i.e. K1' was changed while keeping the ratio K1'/k2' constant); 3) global CBF change affecting both cortical and reference region (i.e. K1 and K1' were changed while keeping the ratios K1/k2 and K1'/k2' constant). The simulated TACs were used to derive SUVR at different time points using three reference regions (CGM, pons, SWM). A composite SUVR

was calculated per subject by averaging the SUVR of six cortical regions (frontal, occipital, parietal, lateral temporal, and posterior and anterior cingulate cortices). The SUVR bias associated with CBF changes was quantified as bias (%) = $(100 \cdot (\text{SUVR} - \text{SUVR}_0) / \text{SUVR}_0)$ where SUVR_0 is the SUVR estimated in those cases where no CBF changes were simulated. **Results:** At pseudo-equilibrium (90-110 min), a 20% regional CBF reduction affecting the reference region caused a decrease of the composite SUVR of $-0.7 \pm 0.9\%$ when using the CGM as RR, and an increase in the composite SUVR of $1.3 \pm 1.2\%$ and $9.4 \pm 1.7\%$ when using the pons and SWM as RR, respectively. When the 20% CBF reduction affected only the target region, the composite SUVR showed a decrease of $-1.8 \pm 1.7\%$, irrespective of the reference region used. A 20% reduction of the CBF affecting both target and reference regions caused a decrease of the composite SUVR using CGM ($-2.5 \pm 1.3\%$) and pons ($-0.5 \pm 1.8\%$) an increase when using SWM ($7.4 \pm 2.4\%$). **Conclusions:** Regional and global CBF changes can bias the amyloid load estimates obtained using 18Fflorbetaben PET SUVR. The influence of CBF on SUVR estimates is small when using the CGM and pons reference region instead of SWM. For most clinical research applications, the SUVR using CGM as reference region approach is sufficient. However, for longitudinal studies in which a large CBF change might occur and maximum quantification accuracy is desired, dynamic acquisition and non-invasive kinetic analysis is recommended.

P76: F-AV-1451 IN TDP-43 ASSOCIATED FRONTOTEMPORAL DEMENTIA. Ruben Smith¹, Alexander F Santillo¹, Maria Landqvist Waldö², Oskar Hansson^{1,3} ((1) *Clinical Memory Research Unit, Department of Clinical Sciences Malmö, Lund University, Lund, Sweden*; (2) *Memory Clinic, Ängelholm Hospital, Ängelholm, Sweden*; (3) *Memory Clinic, Skåne University Hospital, Malmö, Sweden*)

Background: Determining the underlying molecular pathology in frontotemporal dementia (FTD) ante mortem represents a challenging, but important, task for the clinician. Identifying the etiology becomes especially important when recruiting patients to potential future treatment studies. With the development of tau-binding positron emission tomography (PET) radiotracers novel tools for assessing tau pathology in vivo has emerged. The tau PET ligand 18F-AV-1451 performs well in Alzheimer's disease (AD), but with inconsistent but sometimes promising results in other tauopathies. In TAR DNA-binding protein 43 (TDP-43) associated FTD, 18F-AV-1451 retention has been reported in vivo in the semantic variant of primary progressive aphasia (svPPA)/semantic dementia (SD). The neuropathology in svPPA/SD which is strongly associated with type C TDP-43 pathology where dystrophic neurites predominate over neuronal intracytoplasmic inclusions. Behavioural variant FTD (bvFTD) caused by expansions in the C9orf72 gene are instead almost invariably associated to type B TDP-43 pathology, where neuronal intracytoplasmic inclusions predominate over dystrophic neurites. The objective of this study was to determine the behaviour of 18F-AV-1451 in the TDP-43-related proteinopathies, by examining its performance in svPPA/SD and in bvFTD caused by a mutation in the C9orf72 gene. **Methods:** Six bvFTD C9orf72 expansion carriers, six svPPA/SD patients (three of which had an imaging supporting svPPA, and three a right-sided SD), and 54 age-matched neurologically healthy controls were recruited. All subjects underwent 18F-AV-1451 PET scanning and 3T structural MRI

scans. The PET retention was assessed both at the region-of-interest (ROI) and at the voxel-level, using the inferior cerebellar grey matter as a reference region. **Results:** Among patients with svPPA/SD, we found higher tracer retention in the lateral temporal cortices bilaterally compared with healthy controls, in line with previously published results in this disease group. Our findings were mainly driven by 3 of the 6 patients showing increased retention. In other regions no differences were seen using an ROI-based approach. Using a voxel-based approach increased retention was identified in a single significant cluster in the left anterior hippocampus of svPPA/SD patients compared to healthy controls. In the C9orf72 bvFTD patients, binding was not different from controls in the ROI based analysis in any region. Since there are reports indicating cerebellar pathology in C9orf72 patients a complementary analysis was performed, substituting the cerebellum with the pons as reference region. Changing the reference region did not alter the results. The voxel-based analysis showed a sparse, scattered pattern of clusters. **Conclusion:** As previously reported 18F-AV-1451 retention, that could not entirely be explained by amyloid positivity, was seen in some cases of svPPA/SD. The reasons for this retention remains unclear. In patients with type B TDP-43 pathology no AV-1451 retention could be detected, indicating that binding of 18F-AV-1451 in TDP-43 proteinopathies is not a general TDP-43 related phenomenon.

P113: PREDICTING AMYLOID BURDEN FROM COGNITIVE ASSESSMENT. Donald R. Royall^{1,4}, Raymond F. Palmer³ for the Alzheimer's Disease Neuroimaging Initiative* ((1) *Department of Psychiatry, The University of Texas Health Science Center at San Antonio (UTHSCSA), San Antonio, Texas, USA*; (2) *Department of Medicine, UTHSCSA, San Antonio, Texas, USA*; (3) *Department of Family & Community Medicine, UTHSCSA, San Antonio, Texas, USA*; (4) *South Texas Veterans Health Administration Geriatric Research Education and Clinical Center (GRECC), San Antonio, Texas, USA*)

Background: Central Nervous System (CNS) amyloid deposition is thought to be an Alzheimer's Disease (AD)-specific biomarker and has been a target for drug development. Never the less, its cognitive correlates are poorly understood. CNS amyloid can be quantified by Amyvid (Florbetapir) (AV45) by positron emission tomography (PET). However, widespread amyloid screening is constrained by both cost and technical issues. We have developed a new approach to dementia assessment involving the construction of latent variables in a structural equation model (SEM) framework. In SEM, AV45 PET is associated with our "agnostic" omnibus dementia severity metric i.e., "δ" (for "dementia"). This suggests first, that amyloid's effect on dementia risk is mediated through intelligence, and second, that the specific "cognitive correlates of amyloid deposition" can be extracted by methods similar to δ's construction. **Objectives:** Here we demonstrate our ability to predict AV45 PET burden solely on the basis of cognitive performance in data provided by the Alzheimer's Disease Neuroimaging Initiative (ADNI) (N ≈ 1,750). **Methods:** "dT2A" is a δ homolog engineered to replicate findings between the Texas Alzheimer's Research and Care Consortium (TARCC) and ADNI. dT2A is indicated by a battery of six cognitive measures common to both cohorts. dT2A's target indicator in ADNI is the Functional Activities Questionnaire (FAQ). First, we regressed AV45 PET burden onto each of dT2A's cognitive indicators.

Next, we introduced a latent variable indicated by the same set of measures. This variable, i.e., “g’”, represents the fraction of Spearman’s general intelligence factor “g” that is residual (i.e., unrelated) to amyloid as measured by AV45 PET. Next, we fixed g’ ’s parameters. Next, we introduced a second latent variable, i.e., “d”. d represents the fraction of g that is related to amyloid burden as measured by AV45 PET. We confirmed d’s significant association with AV45 PET by correlation. Next, we used AV45 PET burden as the “target” indicator of a bifactor δ “paralog” i.e., “dAV45”. In genetics, a paralog is a gene descended from an ancestral gene in the same species but often having a novel function. dAV45’s residual in d (i.e., the fraction of d that is NOT related to amyloid as measured by AV45 PET) was labeled “g” “. g’ ’s parameters were fixed as well. Next, observed AV45 PET was removed from dAV45’s indicators, leaving only cognitive indicators. We confirmed this construct’s association with amyloid as measured by AV45 PET by correlation, at baseline and at month 24. dAV45’s association with amyloid as measured by AV45 PET was compared with CDR-SB’s and ADAS-Cog’s by multivariate regression. **Results:** dAV45’s final model had excellent fit [i.e., CHI SQ = 11.6 (13), $p = 0.559$; CFI = 1.00; RMSEA = 0.00]. dAV45 correlated significantly with amyloid as measured by AV45 PET (i.e., $r = 1.00$, $p < 0.001$). Similar results were obtained when baseline dAV45 was used to predict month 24 AV45 ($r = 0.98$, $p < 0.001$) (Figure 1). dAV45’s association with AV45 was independent of ADAS-Cog, stronger than ADAS-Cog’s and partially attenuated ADAS-Cog’s. dAV45’s association with amyloid as measured by AV45 PET was independent of CDR-SB, stronger than CDR-SB’s and fully attenuated CDR-SB’s. **Conclusions:** This analysis provides proof of concept for our ability to accurately predict amyloid burden as measured by AV45 PET from cognitive performance alone. Our approach implicates intelligence as the mediator of amyloid’s associations with cognitive performance. Because g is “indifferent” to its cognitive indicators, we should be able to achieve similar results from any convenient cognitive battery including, but not limited to, telephone assessments, bedside screening measures, and /or the itemsets of individual screening tests.

Figure 1

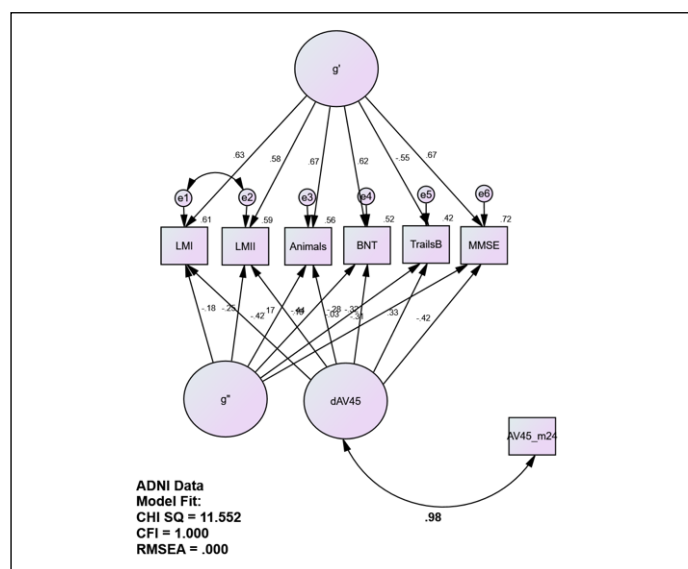

P114: THE TRIPLE USE OF AMYLOID PET IN ALZHEIMER’S DISEASE. Federica Ribaldi^{1,2}, Moira Marizzoni¹, Valentina Garibotto³, Michela Pievani¹, Giovanni B Frisoni^{1,3} ((1) IRCCS Fatebenefratelli, Brescia - Italy; (2) University of Brescia, Brescia – Italy 3 Geneva University Hospitals, Geneva - Switzerland)

Background: Amyloid imaging allows in vivo detection and quantification of amyloid burden, a core pathological hallmark of Alzheimer’s disease (AD). Several amyloid tracers have been approved in the past years and are now commercially available for clinical use or to identify amyloid-positive patients for clinical trial enrichment. Preliminary evidence suggests two additional uses of amyloid PET. First, early frames of amyloid PET can be used to estimate brain perfusion, a proxy of brain metabolism (1). Secondly, the concept of white matter (WM) off-target amyloid binding has been recently questioned by aging and multiple sclerosis studies suggesting that it may reflect myelin binding (2,3). Moreover, our preliminary results in AD and MCI patients showed reduced uptake of amyloid tracers in white matter (WM) lesions compared to normal appearing WM, confirming the myelin hypothesis of WM amyloid uptake (4). **Objective:** The aim of this work is to investigate whether, besides amyloid burden, amyloid PET could be used to measure hypo-perfusion and myelin damage in AD. **Methods:** Hypo-perfusion analyses. We selected 45 subjects, including healthy subjects (HC), patients with mild cognitive impairment (MCI) and AD dementia from ADNI cohort for whom both FDG and early frames (6 minutes) of eFlorbetapir PET scans were available. Standardized uptake value ratio (SUVr) was calculated in 5 regions of interest (ROIs) known to be hypometabolic in AD (Left and right angular, Bilateral posterior cingulate, left and right temporal) (5, 6). The agreement between FDG PET and eFlorbetapir SUVr was assessed by using Pearson’s correlation. Myelin-related analysis. To evaluate whether amyloid PET could detect myelin damage, we tested the concordance between radial diffusivity (RD) index obtained from diffusion tensor imaging (DTI) and amyloid PET SUVr in AD damaged tracts. We selected 49 subjects (HC, MCI, AD) with both DTI and Florbetapir PET scans from ADNI cohort. Radial diffusivity (RD), a measure of myelin integrity, was extracted in the major WM tracts using the Johns Hopkins University as template (JHU). A global mask of demyelinated tracts was obtained by binarizing those WM tracts showing increased RD in patients compared to controls. For each subject, the global mask was rigidly coregistered to the corresponding amyloid PET scan. The concordance between SUVr and RD values was tested using Pearson’s correlation. **Results:** FDG PET and eFlorbetapir SUVrs showed a moderate to strong correlation in all the evaluated regions ($0.60 \leq r \leq 0.69$; $p < 0.001$). The mean (\pm SD) SUVr within AD hypometabolic ROIs was 1,263 ($\pm 0,200$) for FDG PET and 1,238 ($\pm 0,090$) for eFlorbetapir ($p < 0.001$). DTI analysis showed increased RD in patients compared to controls in the corpus callosum (including also the splenium, body, and genu; $p < 0.010$ Mann-Whitney test). SUVr ($1,927 \pm 0,318$) and RD ($0,001 \pm 0,001$) values calculated in those damaged tracts showed a significant inverse correlation ($r = -0,66$, $p < 0,001$). **Conclusions:** Our findings support the view that early frames of amyloid PET could provide a proxy measure of AD hypometabolism, and that amyloid PET is sensitive to microstructural myelin damage. The triple use of amyloid PET could allow better patients screening in clinical trials, by providing a better subject selection

and stratification for AD biomarkers with only one technique, meanwhile reducing patients' burden. References: 1 Garibotto et al., *Eur J Nucl Med Mol Imaging*, 2016; 2 Stankoff et al., *Anna Neurol*, 2011; 3 Glodzik et al., *Eur J Nucl Med Mol Imaging*, 2015; 4 Ribaldi et al., *AAIC 2018*; 5 Jagust et al., *Alzheimer's Dement*, 2015; 6 Landau et al., *Neurology*, 2010.

P115: A COMPARISON OF CORTICAL REPORTER REGIONS FOR LONGITUDINAL ANALYSIS OF 18F-AV1451 PET DATA. David Scott¹, Katarzyna Adamczuk¹, Beth Gorman², Maureen Runkle², Joyce Suhy¹ and the Alzheimer's Disease Neuroimaging Initiative ((1) *Bioclinica, Newark, CA, USA*; (2) *Bioclinica, Philadelphia, PA, USA*)

Background: The accumulation of misfolded phosphorylated tau protein into neurofibrillary tangles (NFTs), and their interaction with amyloid- β plaques, is part of a neurodegenerative cascade toward the development of Alzheimer's Disease. 18F-AV1451 PET allows in vivo visualization of tau pathology. In contrast to amyloid PET, where uptake is present throughout the cortex and can be captured as SUVR within standard cortical composites, tau PET may follow a more complex spatiotemporal staging pattern as identified neuropathologically by Braak et al. 1991, 2006. In the case of amyloid PET, uptake is typically assessed within a composite of temporal, parietal / precuneus, cingulate, and frontal regions. In the case of tau PET, composites consisting of lateral temporal, lateral parietal, medial parietal, and medial temporal regions have been proposed. The full spectrum of Braak stage-related areas is achieved by including frontal and occipital regions. We sought to perform a fine scale analysis of tau burden throughout the brain, to identify those subregions and composites which best separated subjects by diagnosis, and best captured longitudinal change in tau PET. **Methods:** 89 Cognitively Normal (CN), 72 Mild Cognitive Impairment (MCI) and 15 Alzheimer's Disease (AD) subjects from the ADNI database (<http://adni.loni.ucla.edu>) with at least one AV-1451 PET exam were identified. 22 MCI and 18 CN subjects with one follow-up AV-1451 PET exam were identified for longitudinal analysis (average between exams 430 days \pm 104). The ADNI PET core leverages FreeSurfer to segment and parcellate the brain into over 100 anatomically-derived subregions as defined on MRI. Following coregistration with PET, intensity within each subregion is converted to SUVR by normalization to intensity within cerebellar cortex. SUVR within Braak stages 1 through 6 for each subject exam were pre-calculated by the ADNI PET core. In addition, we independently investigated SUVR within lateral and medial temporal cortex, and lateral and medial parietal cortex, by combining appropriate subregions to form a standard-composite. Further, we tested the impact of averaging, summing and weighting regional values when computing a Braak-composite SUVR. Finally, information from the entire FreeSurfer parcellation was input into a LASSO-regularized logistic regression model with five-fold cross-validation. Rather than using least squares to fit a linear model with a subset of predictors, regularization uses all possible predictors but shrinks their coefficient estimates toward zero. Subregions surviving LASSO model estimation were combined to form a single LASSO composite index. The performance of each composite was assessed cross-sectionally (SUVR by diagnosis at exam 1) and longitudinally (change in SUVR from exam 1 to exam 2) by comparing Cohen's d effect size. **Results:** The LASSO model revealed a set of regional features that

best separated groups by diagnosis at exam 1. Those features did not entirely overlap with subregions demonstrating the largest individual effect sizes, and crossed Braak stages (stage 3, amygdala and lingual gyrus; stage 5, superior temporal sulcus, precuneus and superior parietal). Cross-sectionally, the Braak stage 1 (entorhinal cortex) composite best separated AD from CN subjects ($d = 1.4$), while the medial temporal composite best separated MCI from CN subjects ($d = 0.4$). Longitudinal effect sizes were smaller, but Braak stage 1 again demonstrated the largest effect size for increasing SUVR in MCI ($d = 0.3$) and CN subjects ($d = 0.1$). Across composites, longitudinal change was consistently modest at the group level, with most subjects demonstrating $\pm 5\%$ change over time, and MCI subjects trending toward decreased SUVR over time. Different approaches to summing, weighting and averaging SUVR had minimal impact overall. The LASSO index performed comparably to Braak stage 1 cross-sectionally and captured increasing SUVR in CN subjects. However, at the group level the LASSO index captured decreasing SUVR in MCI subjects, though also reflected the greatest dynamic range, with some subjects increasing or decreasing by 10%. **Conclusions:** Across diagnostic groups and over time, a composite region incorporating Braak stage 1 (entorhinal cortex) appeared the most robust index of tau pathology as assessed by 18F-AV1451 PET. Beyond stage 1, each additional Braak stage captured less evidence of group differences or longitudinal change, though stages 2 and 3 performed similarly to stage 1 in differentiating MCI from CN subjects. The LASSO algorithm converged on a set of regional features which best separated diagnostic groups, though these subregions did not effectively capture longitudinal change at the group level. These results suggest while a number of different composites may capture group-level differences based on disease state, evidence of change in SUVR over time varies greatly across subjects and may require more adaptive, subject-specific modeling of longitudinal effects.

Figure 1
Cross-sectional and longitudinal effect sizes across cortical composites

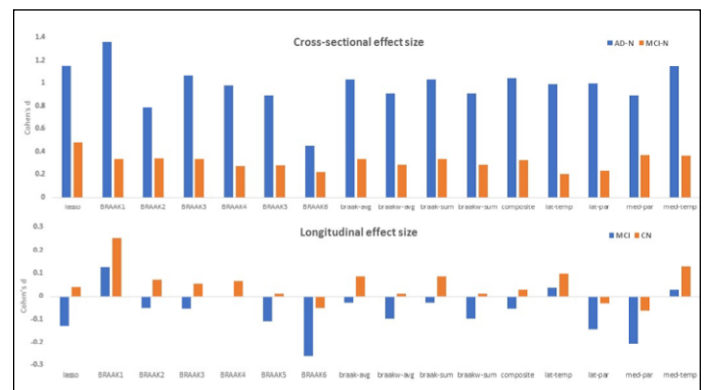

P116: CAN TAU PET IMAGING BE INSTRUMENTAL IN PREDICTING AN ELEVATED AMYLOID LEVEL IN CLINICAL TRIALS.

Sergey Shcherbinin¹, Michael J. Pontecorvo², Ming Lu², Michael D. Devous Sr², A. Joshi², Sudeepti Southeikal², Emily C. Collins^{1,2}, Adam S. Fleisher², Mark A. Mintun^{1,2} ((1) Eli Lilly & Co, Indianapolis, IN, USA; (2) Avid Radiopharmaceuticals, Inc., Philadelphia, PA, USA)

Background: Amyloid β plaques and fibrillary tau are the hallmarks of neuropathologically defined Alzheimer’s disease (AD). Moreover, abnormal levels of both amyloid and tau depositions constitute biologically defined AD (Jack CR et al, Alzheimer’s & Dementia, 2018). Therefore, it’s critical to understand the relationship between these two biomarkers and optimize their implementation in clinical trials. **Objectives:** We examined subgroups of cognitively impaired patients determined using an AT classification system. Aiming at an optimization of the interventional clinical trial screening, we explored whether suprathreshold 18F-Flortaucipir cortical standardized uptake value ratio (SUVR) was associated with an elevated amyloid level. **Methods:** 18F-Florbetapir and 18F-Flortaucipir PET images obtained in the A05 phase 2 study (NCT 02016560) were analyzed for participants diagnosed with either mild cognitive impairment (MCI) due to AD or AD dementia. Specifically, baseline 18F-Florbetapir and longitudinal (baseline and 18-month follow-up) 18F-Flortaucipir images for MCI (N=97, age=70.8 \pm 9.3, ADAS-Cog11=10.3 \pm 4.5) and AD (N=48, age=73.9 \pm 9.2, ADAS-Cog11=20.1 \pm 8.4) patients were investigated. For both modalities, subgroups with elevated cortical amyloid (“A+”) and tau (“T+”) depositions were quantitatively segmented using tracer-specific methods and SUVR cut-points. For 18F-Florbetapir images, SUVR was calculated (Clark CM et al, JAMA, 2011) using six target cortical regions and whole cerebellum as a reference region (abetaSUVR CER); elevated amyloid level was established based on a previously reported criterion (abetaSUVR CER>1.10; Joshi A et al, JNM, 2012). For 18F-Flortaucipir images, SUVR in a posterior neocortical region of interest (MUBADA, Devous MD et al, JNM, 2017) with respect to a reference signal intensity in white matter (tauSUVRW M, Southeikal S et al, JNM, 2018) was calculated. As an exploratory “T+” cut-point, a threshold tauSUVRW M=1.10 approximately corresponding to an upper limit (mean+2.5 SD) of the distribution in young cognitively normal A05 participants (N=16, age=28.9 \pm 4.9, ADAS-Cog11=4.1 \pm 2.5), was used. An elevated tau burden in atlas-based lateral temporal, parietal and frontal lobes was determined analogously. Associations between “A” and “T” conditions were first examined using positive and negative predictive values, PPV and NPV, respectively. Next, four subgroups (Jack CR et al, Alzheimer’s & Dementia, 2018) corresponding to different biomarker profiles [“A-T-” (normal biomarkers), “A+T-” (AD pathologic change), “A-T+” (Non-AD pathologic change) and “A+T+” (AD)] were compared in terms of size, demographic and cognitive characteristics using mixed effect model repeated measurements. **Results:** The utilized stratification methods enabled baseline scans to be split into “A-T-” (44 MCI and 15 AD), “A+T-” (28 MCI and 8 AD), “A-T+” (2 AD) and “A+T+” (25 MCI and 23 AD) categories. Notably, only 3% of amyloid negative “A-” participants had elevated neocortical tau burden. An elevated neocortical tau uptake tauSUVRW M was strongly associated with an elevated amyloid level for either MCI (PPV=100%) or AD (PPV=92%) participants. Moreover, the “T+” condition was largely linked with amyloid

level notably exceeding an amyloid positivity threshold of 1.10. In the combined cognitively impaired (MCI and AD) population, 43/61 (70%) subjects with abetaSUVR CER>1.30 had an elevated “T+” flortaucipir signal vs only 5/23 (22%) subjects with abetaSUVR CER between 1.10 and 1.30. However, having no elevated tau burden did not necessarily presume the absence of elevated amyloid level for either MCI (NPV=61%) or AD (NPV=65%) patients. Regarding associations with cognitive assessments, we found that several characteristics of “A+T-” and “A+T+” subgroups were substantially different suggesting a heterogeneous structure of the “A+” category. Specifically, having both elevated amyloid and tau (“A+T+”) was associated with significantly worse baseline cognitive score (ADAScog-11; p<0.001), as well as greater cognitive decline (p=0.0021) and tau accumulation (p=0.0017) over 18 months as compared to the “A+T-” group. Interestingly, the sample size of the “T+” category, portion of MCI participants, and NPV, were reduced when looking at lobar regions of interest including temporal (19 MCI, 22 AD, NPV=58%), parietal (14 MCI, 21 AD, NPV=55%) and frontal (9 MCI, 17 AD, NPV=50%) lobes. **Conclusions:** Exploratory analysis of a relatively small (N=145) dataset suggested that an overwhelming (>95%) majority of cognitively impaired patients with an elevated cortical tau would have an elevated amyloid level. In addition, tau positivity is characterized by higher and more consistent rates of cognitive decline than amyloid positivity in the absence of tau on PET imaging.

Figure 1

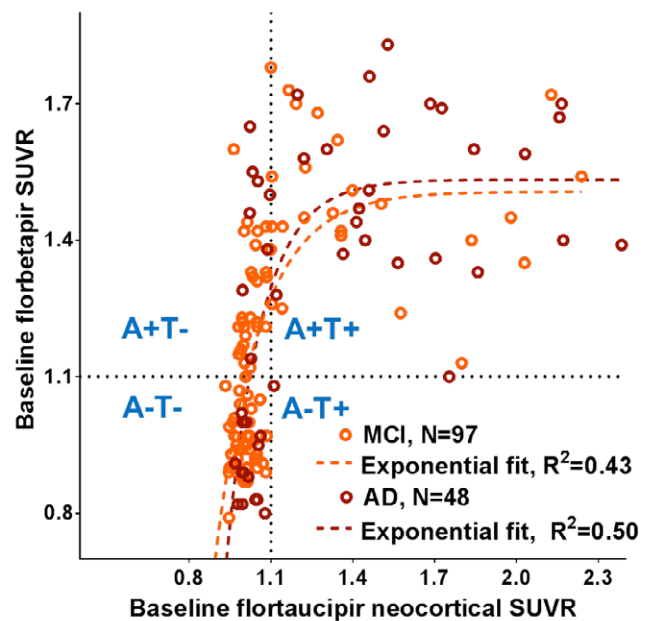
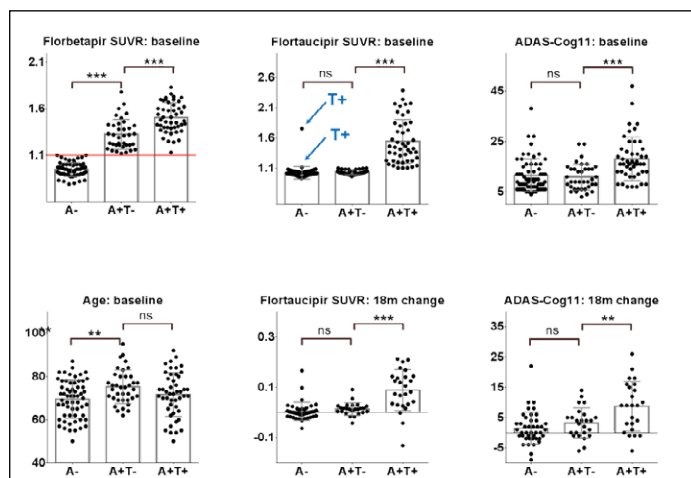

Figure 2



P117: SUPRATENTORIAL WHITE MATTER IS A BETTER REFERENCE FOR LONGITUDINAL QUANTIFICATION OF [18F]FLUTEMETAMOL SCANS. Gemma Salvadó¹, Chris Foley², Elisabetta Grecchi^{2,3}, M. Jorge Cardoso^{4,5}, Isadora Lopes-Alves⁶, Pawel Markiewicz⁵, Carles Falcon¹, Mark Battle², Adriaan A. Lammertsma⁶, Mark Schmidt⁷, José Luis Molinuevo¹, Frederik Barkhof^{5,6}, Juan Domingo Gispert¹ ((1) *Barcelonaβeta Brain Research Center, Barcelona, Spain*; (2) *GE Healthcare, Amersham, United Kingdom*; (3) *IXICO, London, United Kingdom*; (4) *King's College London, London, United Kingdom*; (5) *University College London, London, United Kingdom*; (6) *VU Medical Center, Amsterdam, The Netherlands*; (7) *Janssen Pharmaceutica, Beerse, Belgium*)

Background: Amyloid PET allows detection of changes in cerebral fibrillary amyloid deposition in longitudinal studies that may serve as an outcome measure in clinical trials in Alzheimer's disease. However, these longitudinal changes can have small effect sizes and are affected by the selection of a reference region (RR). The Centiloid project [3] developed a scale for amyloid PET quantification that aims to standardize results across tracers, centers and methods. The standard pipeline includes preprocessing instructions and also target ROI and four RRs masks in the MNI space to harmonize the results. However, none of the four RRs used in the Centiloid include supratentorial white matter (sWM), which has been proposed as an alternative to the typical RRs [1,2]. **Objectives:** To compare the performance of different sWM RRs with those of the infratentorial Centiloid RRs for longitudinal [18F]Flutemetamol PET studies. **Methods:** Baseline and follow up (577±55 days) MRI and [18F]Flutemetamol PET scans were acquired from 125 participants within the AIBL study [4]. A single amyloid global uptake measure was calculated from each PET scan using the standard Centiloid pipeline and different RRs. Three types of RRs were examined: 1) Atlas-based sWM masks using 3 different atlases and 4 erosion levels, 2) standard infratentorial Centiloid RRs, and 3) Subject-specific sWM based on SPM white matter segmentation with successive erosions. Performance of these RRs was assessed by 1) calculating the effect size (Cohen's d) of changes in subjective cognitive decline subjects ([SCD], N=50) and mild cognitive impairment subjects ([MCI], N=21) as both groups are prone to be amyloid accumulators, 2) using test-retest stability of the RRs assessed in subjects with

the lowest accumulation rate ($\Delta\text{SUVR} < 0.004$) [5] and stratified by amyloid status, and, by 3) determining plausibility, i.e. the percentage of subjects with a non-negative amyloid change (tested in all subjects). **Results:** All RRs from the sWM showed significantly larger effect sizes than typical infratentorial Centiloid RRs in both MCI and SCD groups (Figure 1), and were significantly more plausible (Figure 2a). Most sWM RRs also showed better reproducibility but differences did not reach statistical significance against some Centiloid RRs (Figures 2b and 2c). **Conclusions:** sWM RRs outperform standard Centiloid RRs by better capturing small changes in amyloid load along the natural history of AD. Atlas-based sWM RRs allow easier automation and perform similarly to subject-specific sWM RRs. Results suggest that sWM RR might be preferable for detecting longitudinal changes in clinical trials. However, the influence of white matter vascular lesions in amyloid uptake in sWM is not fully understood and deserves further study. **Acknowledgements:** Authors would like to acknowledge Dr. Christopher C. Rowe on behalf of AIBL for sharing [18F] Flutemetamol PET scans with the EPAD/AMYPAD consortium. **References:** [1] Landau et al., *J. Nucl. Med.*, 56(4), 2015; [2] Chen et al., *J. Nucl. Med.*, 56(4), 2015; [3] Klunk et al., *Alzheimer's Dement.*, 11(1), 2015; [4] Ellis et al., *Int. Psychogeriatrics*, 22(4), 2009; [5] Jack et al., *Neurology*, 80(10), 2013

Figure 1

RRs performance in detecting longitudinal amyloid changes. Mean and 95% CI effect size with all RRs for MCI (n=21) and SCD (n=50) groups, a) and b), respectively. Statistically equivalent (worse) results were those that did (not) overlap their 95% CI with that of the best result.

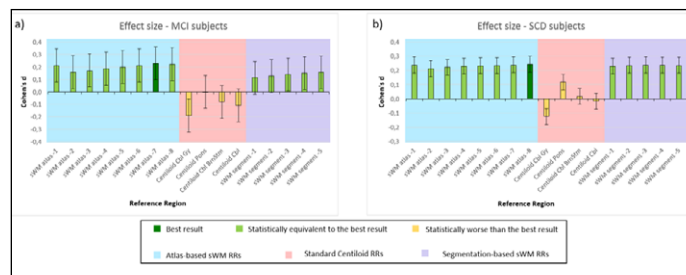

sWM auto: atlas-based supratentorial white matter, Cbl Gy: grey cerebellum, Cbl BrnStm: whole cerebellum and brainstem, Cbl: whole cerebellum, sWM segment: sWM from SPM segmentation.

Figure 2

RRs longitudinal stability of RRs. a) Plausibility, as the percentage of subjects that have a non-negative amyloid accumulation. b) and c) Mean and 95%CI of test-retest for amyloid positive stable (n=14) and amyloid negative stable (n=57). For plausibility, differences from the best results were calculated with χ^2 test. For test-retest, statistically equivalent (worse) results were those that did (not) overlap their 95% CI with that of the best result

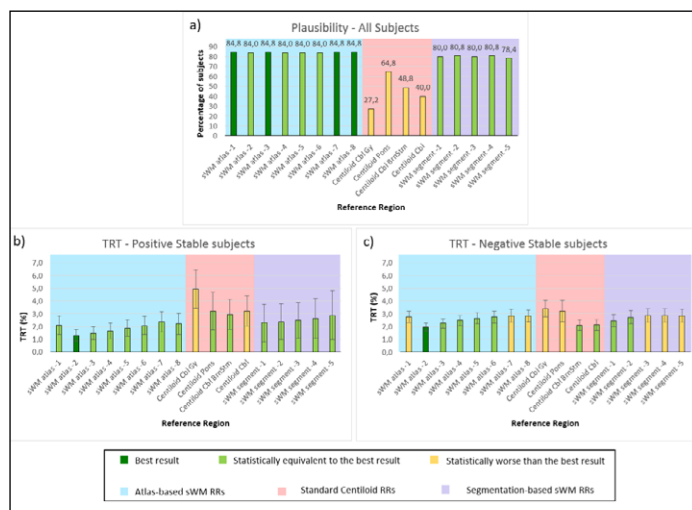

sWM auto: atlas-based supratentorial white matter, Cbl Gy: grey cerebellum, Cbl BrnStm: whole cerebellum and brainstem, Cbl: whole cerebellum, sWM segment: sWM from SPM segmentation.

P118: CLINICAL VALIDATION OF 18F-PI-2620 FOR QUANTIFICATION OF TAU IN SUBJECTS WITH ALZHEIMER'S DISEASE. Andrew Stephens¹, Andre Mueller¹, Santiago Bullich¹, Mathias Berndt¹, John Seibyl², Olivier Barret², Jennifer Madonia², Heiko Kroth³, Andrea Pfeifer³, Andreas Muhs³, Gilles Tamagnan², Kenneth Marek², Ludger Dinkelborg¹ ((1) Piramal Imaging, Berlin, Germany; (2) Inivicro, New Haven, USA; (3) AC Immune SA, Lausanne, Switzerland)

Background: Intracellular tau deposition is a key pathological feature of Alzheimer's disease (AD) and other neurodegenerative disorders. 18F-PI-2620 is a novel tau PET-tracer with a high binding-affinity for aggregated tau. Pre-clinically, 18F-PI-2620 binds to 3R and 4R tau isoforms and is therefore able to depict tau-deposits in AD brain sections from different Braak stages, as well as deposits in non-AD tauopathies. The ability of PI-2620 to measure the spatial distribution of tau pathology by PET imaging was already demonstrated. To extend the utility of PI-2620 for use in therapeutic clinical trials, a Test/Retest study with arterial sampling and simplified quantification methods were explored. **Methods:** In an ongoing clinical imaging study, participants diagnosed with mild AD, as well as non-demented controls (NDCs) are recruited and undergo dynamic PET imaging for 180 minutes with 18F-PI-2620. The PET data from NDC subjects were used to generate a normal database for comparison. PI-2620 Tau PET data from additional AD subjects were used to extend the analysis of tau distribution. In addition, 3 NDC and 3 AD subjects underwent a Test/Retest study including repeat-scanning within 21 days and arterial sampling with metabolite correction. Distribution volume ratios (DVRs) were determined using full tracer kinetic models and reference

tissue models. Standardized uptake value ratios (SUVR) were determined at different time points p.i. using inferior cerebellar cortex as reference region. SUVR and the correlation with BPND was analyzed to determine the pseudo-equilibrium time and optimal scan time. Test-retest variability was calculated as percent difference between test and retest scans. **Results:** Imaging data show robust brain uptake and fast wash-out in non-target regions with peak SUVs > 4 similar to what has been observed before. There was no increased off-target binding, and no age-related increase seen in subcortical brain regions like basal ganglia as noted for first generation tau agents. Focal asymmetric uptake was evident in temporal and parietal lobes, precuneus, and posterior cingulate in the AD subjects. The time-activity curves were well described by the 2-tissue-compartment model (2TC). SUVR measured at 60-90 min p.i. correlated well with 2TC (slope 1.37, $r^2 = 0.97$) and non-invasive Logan plot (slope 1.3, $r^2 = 0.93$). The average Test-Retest variability in AD was 2.1 % \pm 8.0 (2TC), 3.3 % \pm 6.1 (non-invasive Logan) and 7.8 % \pm 8.6 (SUVR). SUVRs at 60-90 min were significantly lower in non-demented controls (SUVR 1.0-1.2) than in AD subjects (SUVRs up to 4) in the same brain regions. **Conclusion:** 18F-PI-2620 PET data in AD and NDC demonstrate favorable kinetics and high target specificity with low off-target activity and high signal in regions of expected tau pathology. Non-invasive quantification using SUVR at 60-90 min p.i. provides significant discrimination between NDC and AD subjects. The excellent Test-Retest variability confirms the utility of PI-2620 to evaluate change of tau deposition in longitudinal studies.

P119: CUT-OFF FOR 18F-FLUTEMETAMOL SUVR WITH WHITE MATTER REFERENCE REGION. Katarzyna Adamczuk¹, David Scott¹, Ben Newton³, Joyce Suhy¹, Michael Egan², Cyrille Sur² ((1) Bioclinica, Newark, CA, USA; (2) Merck Sharp & Dohme, Kenilworth, NJ, USA; (3) General Electric Health Care, Amersham, UK)

Background and Objectives: Recent data indicates that using white matter (WM) as a reference region in standard uptake value ratio (SUVR) calculations will result in longitudinal assessment with less variability. Our objective in this work was to evaluate the potential benefits of using WM as a reference region in the analysis of 18F-flutemetamol PET scans. We also assessed the effect of WM reference region on longitudinal SUVR effect sizes and established a SUVR cut-off to define amyloid positivity. The impact of WM reference region on PET tracer test-retest variability was also investigated and a comparison to autopsy confirmed pons based SUVR cut-off was conducted (Thurfjell et al., 2014 JNM). **Methods:** To determine SUVR cut-off for amyloid positive classification we used 162 18F-flutemetamol PET scans from AIBL dataset (<https://aibl.csiro.au/>), including images of subjects with Alzheimer's disease (AD), Mild Cognitive Impairment (MCI), and healthy older adults with (Comp) and without memory complaints (NonComp). The 18F-flutemetamol scans were preprocessed using Statistical Parametric Mapping 12 (SPM12, <http://www.fil.ion.ucl.ac.uk/spm>). The PET image was co-registered to the T1-weighted MRI. The MR image was spatially normalized to the SPM12 T1 template in MNI space using a unified segmentation approach. This generated the nonlinear forward and inverse transformation parameters, as well as grey matter, white matter and cerebrospinal fluid images. The inverse transformation parameters were applied to the co-registered PET image to spatially normalize it to subject's

native MRI space. On PET images in native subject space SUVr values were calculated with white matter as reference region. Mean SUVr value was calculated in a composite cortical region consisting of 5 bilateral areas: lateral frontal, lateral parietal, lateral temporal, precuneus, anterior and posterior cingulate cortex. The white matter reference region was created from subject-specific white matter probability map, thresholded at > 0.7 . To estimate the SUVr cut-off for detecting amyloid positivity using the above described image analysis method, a receiver operating curve (ROC) analysis was performed with clinical diagnosis as a standard-of-truth. Only subjects with Alzheimer's disease and healthy older adults without memory complaints were included. The highest Youden index (sensitivity + specificity - 1) was used to estimate the optimal ROC cut-off. **Results:** Average SUVr values were 0.86 in AD patients, 0.79 in MCI patients, 0.67 in healthy complainers and 0.63 in healthy non-complainers. The resulting SUVr white matter cut-off was 0.69 (AUC 0.928, CI 0.824 to 0.981, $P < 0.0001$, Sensitivity 91%, Specificity 86%). When directly compared to SUVr with pons used as reference region, SUVr with white matter had similar accuracy in discrimination between AD and healthy non-complainers and narrower dynamic range (Figure 1). Calculated SUVr pons cut-off was 0.62 (AUC 0.945, CI 0.847 to 0.989, $P < 0.0001$, Sensitivity 100%, Specificity 79%). The effect size for longitudinal change (Cohen's d) based on SUVr with WM reference region was 1.20 in amyloid positive MCI and 0.65 in amyloid negative healthy non-complainers. The SUVr effect size with brain stem as reference region was 0.45 in amyloid positive MCI and 0.26 in amyloid negative healthy non-complainers. Test-retest variability of the SUVr with WM ranged between 1.1 and 2.3% across regions. Slope of the linear fit and the coefficient of determination (r^2) from the test-retest correlation were 1.02 and 0.99, respectively. **Conclusions:** With the field moving towards using white matter as a longitudinally stable reference region, despite the controversy of the high non-specific binding, one needs to define binary cut-offs. The ability to classify scans in a binary manner and define grey zone around the cut-off is of high clinical relevance even though amyloid accumulation is a continuous process and does not follow a clear cut dichotomous division. We defined SUVr white matter cut-off based on ROC analysis of AIBL subjects and we directly compared white matter and pons reference regions. For the pons, our method exactly reproduced the cut-off found at autopsy (0.62) (Thurfjell et al., 2014 JNM). Using white matter, a novel cut-off for amyloid positivity was defined at 0.69 and a higher effect size to detect longitudinal changes in 18F-flutemetamol signal was observed.

Figure 1

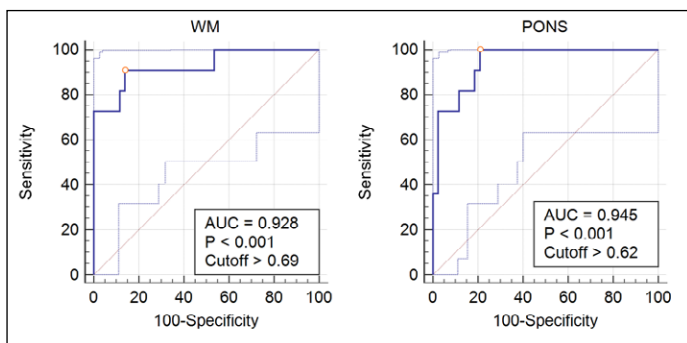

P120: AMYLOID PET IMAGING IN A PHASE IIA, RANDOMIZED, DOUBLE-BLIND, PLACEBO-CONTROLLED, 3-ARM PARALLEL-GROUP, MULTICENTER STUDY WITH UB-311. Hui Jing Yu¹, Hui-Chen Chen¹, Jacob Hesterman², Jack Heimann², Sean Holmes², Alex Whittington², Xue Wang², Roger Gunn², Ajay Verma¹ ((1) United Neuroscience, Inc. Hauppauge, NY, USA; (2) Invicro, A Konica Minolta Company, Boston, MA, USA)

Background: Given that cognitive impairment and loss of function in older people can reflect a myriad of CNS disruptions, it is important to confirm the presence of A β deposition for subject screening in disease modification clinical trials in Alzheimer's disease (AD). A β positron emission tomography (PET) imaging allows evaluation of AD neuropathology in vivo and provides a biomarker for disease modification. UB-311, is an immunotherapeutic vaccine, comprised of A β 1-14-targeting peptide immunogens (B-cell epitopes) linked with one of two synthetic helper T-cell peptide epitopes (UBITh[®]) and is currently in a phase IIa study (V203-AD, NCT02551809). In the V203-AD study, florbetapir (18F-AV-45) PET was performed for patient selection and tracking of amyloid deposition. **Objectives:** Here, the comparative behaviors of amyloid PET imaging biomarkers from the V203-AD study will be presented. **Methods:** PET scans were assessed by independent neuroradiologists and classified as positive or negative by both visual and quantitative assessments. An image processing pipeline incorporating MRI-based registration and grey-matter masking was used to quantify the standard uptake value ratios (SUVr) in a template space using the mean signal of selected cortical brain regions with whole cerebellum as reference. The PET data were also used to calculate Amyloid Load (A β L, a novel biomarker for quantifying amyloid- β , range from 0-100% [1]). The association between baseline and longitudinal changes in SUVr and A β L markers were assessed. **Results:** Out of the 54 subjects who underwent PET screening, 11 were classified as A β negative by visual read, 43 were A β positive and enrolled in the study (Fig 1). The quantitative methods were compared to visual reads for enrollment, with the SUVr method returning a ROC AUC of 0.92 and Cohen's D of 2.23 and the A β L method returning a ROC AUC = 0.99 and Cohen's D of 4.28. The PET data reveal a mean baseline SUVr (SD) of 1.33 (0.11) and a mean baseline A β L (SD) of 52.5% (7.5%) of the 43 randomized subjects. Baseline SUVr PET and A β L were highly correlated ($r = 0.81$, and $p < 5.09E-11$). Of the 29 subjects that completed the week 78 visit to date, the rate of change from baseline in SUVr PET also correlated strongly with A β L ($r = 0.95$, and $p < 1.4E-14$). **Conclusions:** Compared to other AD immunotherapeutic clinical trials using amyloid PET scans, those subjects who progressed to the PET scan screen in the V203-AD study had a low PET screen failure rate of 18.5%. There was good consistency (94.4%) between the visual and quantitative PET scan reads for determining A β positive or negative cases. The A β L method, although highly correlated with SUVr method, exhibited higher sensitivity and specificity for distinguishing amyloid negative and amyloid positive subjects than typical SUVr-based methods. Of the 43 enrolled amyloid PET positive subjects in V203-AD study, 81% were ApoE ϵ 4 carriers. Screening for both APOE ϵ 4 status and amyloid PET imaging may thus provide an accurate and efficient method to identify mild subjects for disease modification trials in AD. Reference: [1] AMYLOID LOAD: A NOVEL BIOMARKER WITH INCREASED SENSITIVITY FOR

Figure 1

Comparison of SUVR (whole cerebellum reference) and amyloid load metrics for evaluating baseline amyloid signal. The dashed lines reflect a large range of amyloid values in which no subjects were observed. A similar separation is not observed in the SUVR values providing increased confidence in the amyloid load metric for as a quantitative method for enrollment

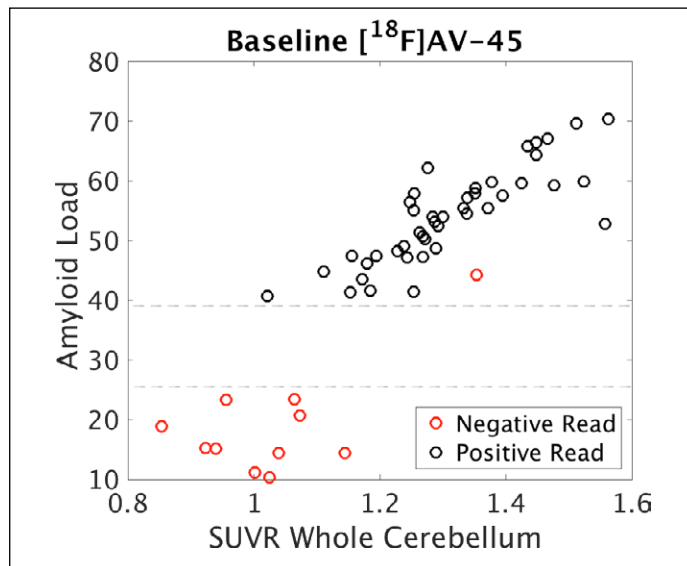

P121: CORTICAL DOPAMINE DEPLETION AND COGNITION IN LEWY BODIES DISORDERS: A 123I-FP-CIT SINGLE-SUBJECT STUDY. Andrea Pilotto^{1,2}, Francesca Schiano di Cola¹, Enrico Premi¹, Roberto Grasso¹, Rosanna Turrone¹, Stefano Gipponi¹, Andrea Scalvini¹, Elisabetta Cottini¹, Barbara Paghera³, Laura Bonanni⁴, Maria Cristina Rizzetti², Barbara Borroni¹, Alessandro Padovani¹ ((1) *Neurology Unit, Department of Clinical and Experimental Sciences, University of Brescia, Brescia, Italy*; (2) *Parkinson's Disease Rehabilitation Centre, FERB ONLUS S.Isidoro Hospital, Trescore Balneario (BG), Italy*; (3) *Nuclear Medicine Unit, University of Brescia, Brescia, Italy*; (4) *Department of Neuroscience Imaging and Clinical Sciences, University G. d'Annunzio of Chieti-Pescara, Chieti, Italy*)

Background: Striatal 123I FP-CIT imaging has been widely used for differential diagnosis of neurodegenerative parkinsonism and dementias. Recently, we developed a Statistical Parametric Mapping (SPM) imaging-method for assessing both cortical and subcortical 123I FP-CIT binding at single-subject level. **Objectives:** In the present study, we applied a whole-brain SPM approach to SPECT 123I-FP-CIT imaging in order to investigate the correlations between cognitive deficits and both subcortical and cortical binding at single-subject level. **Methods:** fifty-two Parkinson's disease patients without dementia and 27 patients with dementia with Lewy bodies underwent a standardized neurological examination and 123I-FP-CIT SPECT. Each imaging was normalized and striatal/cortical regions of interests of 123I FP-CIT binding have been calculated for each subject. The occipital-adjusted binding was compared between patients with and without dementia by ANCOVA adjusted for the effect of age, sex,

disease duration, depression and levodopa equivalent dose. **Results:** patients with dementia displayed significant lower total cortical/striatal, parietal and frontal ratio ($p < 0.001$) despite similar 123FP-CIT binding caudate or putamen compared to patients without dementia. At single-subject level, the binding in specific prefrontal-regions was significantly associated with dementia: prefrontal medio-lateral (AUC 0.958; 95% CI 0.91-0.99, $p < 0.001$), dorsolateral (AUC 0.933, 95% CI 0.88-0.98) and orbitofrontal (AUC 0.91, 95% CI 0.85-0.97). **Conclusions:** dopaminergic cortical imaging correlates with dementia in patients affected by Lewy bodies disorders, in line with striatal dopamine projections and neuropathology data. Further studies are needed in order elucidate the meaning of extrastriatal 123FP-CIT imaging as single-subject marker of dopamine dysfunction Alzheimer's disease and other degenerative dementias.

P122: VERY EARLY DETECTION AND TREATMENT MONITORING OF ALZHEIMER'S DISEASE IN THE RETINA BY MULTIMODE, HYPERSPECTRAL CONFOCAL SCANNING OPHTHALMOSCOPY. Daniel L. Farkas^{1,2}, Fartash Vasefi¹, Jeanne M. Fontana¹ ((1) *The Brain Window, Inc., Sherman Oaks CA, USA*; (2) *University of Southern California, Los Angeles CA, USA*)

Background: Alzheimer's Disease (AD) is a major unmet health challenge characterized by (a) fast increasing incidence and costs; (b) very late diagnosis. **Objectives:** Design and build a new imaging system that can detect an early biomarker of AD (beta amyloid plaques) early and non-invasively, in the retina. **Methods:** Our group has recently [1] introduced optical imaging in the retina as a non-invasive method for mapping the occurrence, size and location of beta amyloid plaques, the primary pathology in AD. We have shown that using the fluorescence of curcumin, which attaches specifically to these plaques, we could quantitate the features of these plaques, including in vivo, and even document their reduction by immune treatments. These preclinical studies were also extended to the clinical domain, by using archival human eyes from patients with known levels of AD, as assessed both by brain histopathology and cognitive impairment (prior to death). We present a method for extending such studies to living patients, still using the retina as the window to the brain and amyloid plaques as indicators, but without the use of an extrinsic biomarker such as curcumin (as was the case in [1]). This raises the level of experimental difficulty, thus requiring new technologies that we invented and/or perfected. **Results:** We designed a multimode optical imaging instrument, essentially a new type of confocal scanning [2] laser ophthalmoscope, with some (needed) performance advantages over current commercial offerings. Our system consists of the following elements, all proprietary, and patent-protected: (a) A highly versatile light source: pulsed, 400-1500 nm, with ~1 nm spectral resolution; (b) A new galvanometric method of scanning, with synthesized, software-controlled pivot point, not requiring a custom coupling lens; (c) Spectral analysis of imaging data, including hyperspectral image segmentation and elimination of background [3, 4]; (d) A more sensitive method of detecting light, via parametric amplification [5]; (e) Fluorescence-specific optical coherence tomography by a new heterodyned detection method. This new instrument achieves significant improvements in all of the following: spatial resolution, imaging depth, imaging angle in the

retina (and thus spatial coverage), sensitivity and specificity. The new instrument can image, fast and non-invasively, amyloid plaques in the retina, and any other retinal features of interest. **Conclusions:** We envisage that this instrument and the approach it enables should be used in AD drug/treatment trials, as it allows the repeatable, non-invasive and quantitative imaging of amyloid plaques (via both their autofluorescence and scattering), and of their relationships with important structures in the eye, such as blood vessels. We believe such new, advanced approaches [6, 7] are needed to broaden neuroimaging, for more effectiveness. Old, unsuccessful clinical trials of AD drug candidates could be revisited, looking for impact on much earlier stages of the disease. This could have clinical, as well as commercial benefits, as intended [8]. References: 1. Koronyo-Hamaoui, M., ... Farkas, D.L. (2011) Identification of amyloid plaques in retinas from Alzheimer's patients and noninvasive in vivo optical imaging of retinal plaques in a mouse model. *NeuroImage*, 54Supl 1: S204-217. (PMID: 20550967); 2. Carver, G.E., ...Farkas, D.L. (2014) High-speed multispectral confocal imaging. *J. Biomed. Optics*, 19: 36016 (PMID: 2465877); Vasefi, F., ... Farkas, D.L. (2014) Polarization-sensitive hyperspectral imaging in vivo: a multimode dermoscope for skin analysis, *Scientific Reports*, 4: 4924, 1-10 (PMID: 24815987); 3. Vasefi F, ... Farkas D.L. (2016) Separating melanin from hemodynamics in nevi using multimode hyperspectral dermoscopy and spatial frequency domain spectroscopy. *J. Biomed Optics*, 21(11):114001. (PMID: 27830262); Nowatzky, A.G. (2014, 2015) Low noise photoparametric solid state amplifier, US patents # 8,901,997 and # 9,213,216.; 4. Vasefi F., MacKinnon N., Farkas D.L., Kateb B. (2017) Review of the potential of optical technologies for cancer diagnosis in neurosurgery: a step toward intraoperative neurophotonics. *Neurophotonics*. 4(1):011010. (PMID: 28042588); 5. Fujimoto, J. and Farkas, D.L. (editors) (2009) *Biomedical Optical Imaging*, Oxford Univ. Press; 6. Farkas, D.L. (2003) *Nature Biotechnology*, 21: 1269-1271.

P123: QUANTITATIVE ANALYSIS ON THE GOODNESS OF HARMONIZATION WITH MULTIVARIATE ANALYSIS OF FIELD STRENGTH, SEX, AGE AND TOTAL INTRACRANIAL VOLUME. Mirza Faisal Beg¹, Da Ma¹, Karteek Popori¹, Mahadev², Lei Wang³ ((1) *School of Engineering Science, Simon Fraser University, Vancouver, BC, Canada*; (2) *Faculty of Medicine, University of British Columbia, Vancouver, BC, Canada*; (3) *Feinberg School of Medicine, Northwestern University, Chicago, Illinois, USA*)

Background: When dealing with large multi-center databases such as Alzheimer Disease Neuroimaging Initiative (ADNI) which includes thousands of brain images, the effects of multiple confounding covariates can enter at multiple steps during data acquisition and analysis, increasing the variability in the data. These confounding variables introduce variability in the measures and may lessen the ability to detect changes due to the actual effect of interest, e.g. changes due to disease. For instance, changes in MRI-derived cerebral structural volumes, such as hippocampal atrophy and ventricle expansion, are important quantitative imaging-biomarkers to analyze disease progression. However, subtle structure changes due to disease may be masked by the inter-subject gross variation such as age, sex and cranial vault size. Variations may also be introduced during data acquisition due to factors such as acquisition sequence, scanner field strength, and scanner

vendors. Data harmonization is an important procedure to remove the sources of data variation and improve the statistical power. However, given its importance, there is currently a lack of tools that can effectively evaluate the harmonization of data as a function of each covariate, either visually or quantitatively. It is therefore necessary to develop an efficient way to evaluate the effect of various covariates that introduce unwanted data variation and access the improvement of data harmonization after removing the corresponding covariates. In this study, we aim to investigate proper methods to assess the "goodness of harmonization" across the entire feature space of the database (structure volume in ADNI dataset in our case) before and after controlling each of the covariates. **Methods:** We controlled the different covariates through hierarchical regression by firstly regress out the scanner-specific batch-effect (field strength), followed by the removal of population variation (TIV), and finally the demographic factors (sex and age). We include the covariates in the general linear model (GLM) and predict the structure volume over the entire database by fitting the GLM with coefficients trained from the reference group (cognitive normal, CN), and compute the normalized residual (w-score). To evaluate the effects of different covariates towards the data harmonization, we first assess the within-group variation by calculating the Z-score of each parcellated structures for each subject with regards to the mean and standard deviation of the CN group as reference group. Next, we calculated the empirical cumulative distribution function (ECDF) both the CN and AD group. We plotted the ECDF of different sex group (male and female) and field strength group (1.5T and 3T) separately (Figure 2). To quantitatively evaluate the goodness-of-fit, we use the two-sample Kolmogorov-Smirnov (K-S) test to compare the ECDF for each covariate (sex, age, and diagnosis), and to distinct the sample distribution between different population subgroups. **Results:** We plotted the Z-score over the entire ADNI database and refer the resulted panorama plot as Zscape (Figure 1). We separated the Zscape into several level of subgroups for better visualizing the effect of each covariates towards the population variation. At the top level, all the ADNI subjects are categorized into different diagnosis groups: CN, Mild Cognitive Impairment (MCI) and Alzheimer's (AD). Within each diagnosis group, subjects were divided into male and female groups, which are then further subdivided into 1.5T and 3T subgroups. Finally, within each subdivided subgroup, the subjects were sorted according to their age at the scan in ascending order to reflect the effect of age. The ECDF and K-S test results (Figure 2) demonstrated improvement in data harmonization by assessing the separation of distribution distance between the disease group, age, sex, field strength of the scanner after controlling each of the confounding covariates. **Conclusion:** In this study, we presented two methods to assess the «goodness of harmonization» on images taken from multiple sites. Our methods demonstrated the improvement of data harmonization using w-score based multivariate linear model. Our results showed data inharmonious caused by the field strength difference during the image acquisition. Such effect could be controlled through TIV normalization using GLM based residual by including the field strength into the model. Sex difference is also found in cerebral volume, with female TIV and gray matter volume significantly smaller than the male. Such sex difference persists after simple division based TIV normalization but can be properly controlled through TIV normalization based on GLM model and taking the residual. In conclusion, we have demonstrated powerful ways to access the

data inharmonious due to various covariates for large database image analysis. and image-acquisition-dependent covariates should be explicitly modelled and properly controlled in the GLM to avoid increasing the data variation. This study showcases techniques to assess the goodness of harmonization, and the results of this study highlight the importance of proper data harmonization as a required preprocessing step when pooling large dataset with multiple covariates, prior to further data analysis.

Figure 1

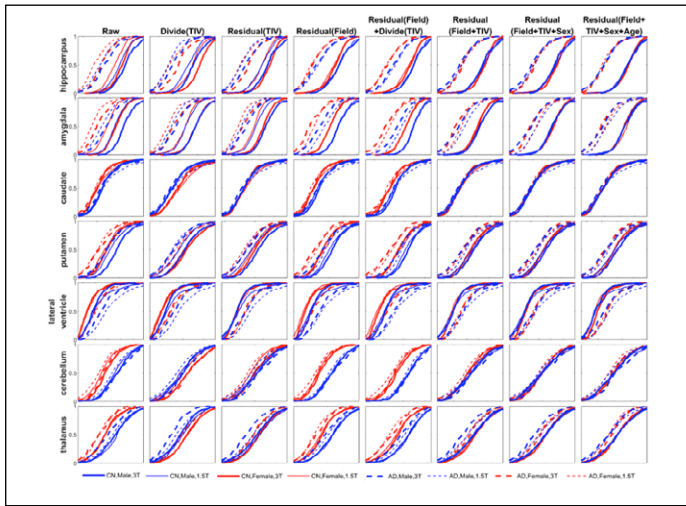
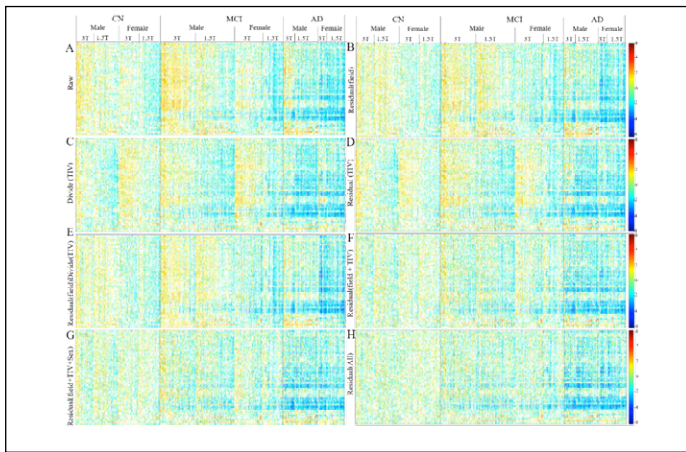

Figure 2



P124: PRESCRIBING CHOLINESTERASE INHIBITORS IN MILD COGNITIVE IMPAIRMENT – OBSERVATIONS FROM THE ALZHEIMER’S DISEASE NEUROIMAGING INITIATIVE. Eddie Stage¹, Diana Svaldi¹, Sophie Sokolow^{2,5,6}, Shannon L. Risacher¹, Krisztina Marosi², Kwangsik Nho¹, Jerome I Rotter^{3,4}, Andrew J. Saykin¹, Liana G. Apostolova¹ ((1) *Indiana Alzheimer Disease Center, Indianapolis, IN, USA*; (2) *UCLA School of Nursing, Los Angeles, CA, USA*; (3) *Division of Genomic Outcomes, Department of Pediatrics and Medicine, Harbor-UCLA Medical Center, Torrance, CA, USA*; (4) *Institute for Translational Genomics and Population Sciences and Department of Pediatrics, Los Angeles Biomedical Research Institute, Torrance, CA, USA*; (5) *UCLA Brain Research Institute, Los Angeles, CA, USA*; (6) *UCLA Clinical and Translational Science Institute, Los Angeles, CA, USA*)

Background: Acetylcholinesterase inhibitors (AChEI) are symptomatic agents used to treat the cholinergic deficit in Alzheimer’s disease (AD). Our previous work showed that ADNI subjects with mild cognitive impairment (MCI) who are treated with AChEI (AChEI+ MCI) exhibit greater cognitive deficits on MMSE and CDR-SB at baseline and faster rate of decline in these measures over time compared to untreated MCI subjects (AChEI- MCI) 1. Whether these differences are due to the use of AChEI or other underlying differences between the treated and untreated group has not been firmly established. **Objective:** Our objective is to determine if AChEI+ MCI individuals differ from AChEI- MCI in regards to neurodegenerative changes at baseline and greater hypometabolism and atrophy over time and whether controlling for any baseline differences will reduce the magnitude of longitudinal between group differences. **Methods:** Of the 274 MCI subjects in our previous study, 272 subjects had MRI scans (121 AChEI+ and 151 AChEI-) and 192 subjects had FDG scans (82 AChEI+ and 110 AChEI-). 181 and 137 subjects from the MRI and the FDG cohorts, respectively, had CSF or amyloid PET assessment for amyloid pathology (i.e. biomarker validated cohort). Amyloid positivity was determined using [18F]AV-45-PET SUVR \geq 1.17 or A β CSF $<$ 192 pg/mL. Baseline analyses used voxelwise regression in SPM’s base package while, longitudinal analyses utilized the Sandwich Estimator (SwE) toolbox for SPM. We controlled for age, sex, and education in all analyses. In the MRI analyses we also controlled for intracranial volume and magnetic field strength. Multiple comparison correction was done using cluster-level Family Wise Error correction thresholded at $p < 0.05$. The MRI and FDG full cohort longitudinal analyses were repeated after controlling for baseline hippocampal volume or PCC SUVR, respectively. In the biomarker validated cohort we also controlled for amyloid positivity. **Results:** A significantly greater proportion of AChEI+ MCI subjects were amyloid-positive as compared to AChEI- in both the MRI and FDG cohorts. AChEI+ MCI subjects scored significantly higher on baseline CDR-sum-of-boxes (MRI cohort: $p=0.009$; FDG cohort: $p=0.041$) and lower on MMSE (MRI cohort: $p=0.008$; FDG cohort: $p=0.011$) than AChEI- MCI subjects. Rate of decline in CDR-sum-of-boxes and MMSE was significantly higher in AChEI+ than in AChEI- MCI subjects in both the MRI and FDG cohorts ($p<0.001$ and $p=0.005$, respectively). In the full MRI sample (N=272) the AChEI+ MCI group had significantly reduced GMD in hippocampi and lateral temporal cortices at baseline and significantly greater rate of atrophy in the medial temporal, lateral temporal, lateral parietal, and prefrontal cortices over 48 months compared to AChEI- MCI. After correction for baseline hippocampal atrophy in the longitudinal models, no significant voxels remained at $FDR<0.05$ (Figure 1 top row). In the full FDG sample (N=192) the AChEI+ MCI group had significantly reduced SUVR in the PCC and the left angular gyrus at baseline (Figure 2) and significantly greater rate of left greater than right hypometabolism of the medial temporal, lateral temporal, lateral parietal, and prefrontal cortical areas over 48 months compared to AChEI- MCI. After correction for baseline PCC hypometabolism, the longitudinal differences were significantly attenuated and only a small area of the PCC survived (Figure 1 bottom row). The biomarker validated sample (N=181 for MRI and N=137 for FDG) allowed us the opportunity to study whether the different rates of progressive neurodegeneration can be explained by the greater proportion of amyloid positive subjects among the AChEI+

MCI. At baseline, these subsets showed similar differences in atrophy and hypometabolism as the full cohorts. The baseline signal was marginally reduced by controlling for amyloid positivity. Longitudinally, differences between the treated and untreated groups were only seen in the MRI subset. These difference also persisted after controlling for amyloid status (Figure 2). **Conclusions:** MCI subjects who were already taking AChEIs were significantly more likely to be amyloid positive and showed greater baseline and longitudinal atrophy and hypometabolism, than subjects not prescribed AChEIs. This indicates that physicians are more likely to attribute cognitive changes to AD and initiate therapy in MCI individuals when they see evidence of neurodegeneration. However our data shows that the differences in rates of cognitive decline, atrophy, and hypometabolism observed in the AChEI+ vs. AChEI- MCI group cannot be fully explained by the presence of amyloid pathology. This suggests that the assumption of underlying AD etiology using markers of neurodegeneration is in many instances misleading, underscoring the importance of physicians to have access to ascertainment of amyloid pathology and the need for insurance coverage for amyloid imaging in clinical settings. 1. Sokolow, S et al 2018 Acetylcholinesterase Inhibitor Therapy in Mild Cognitive Impairment: Yes or No? Submitted for AAIC 2018

Figure 1
Significance maps for full cohort

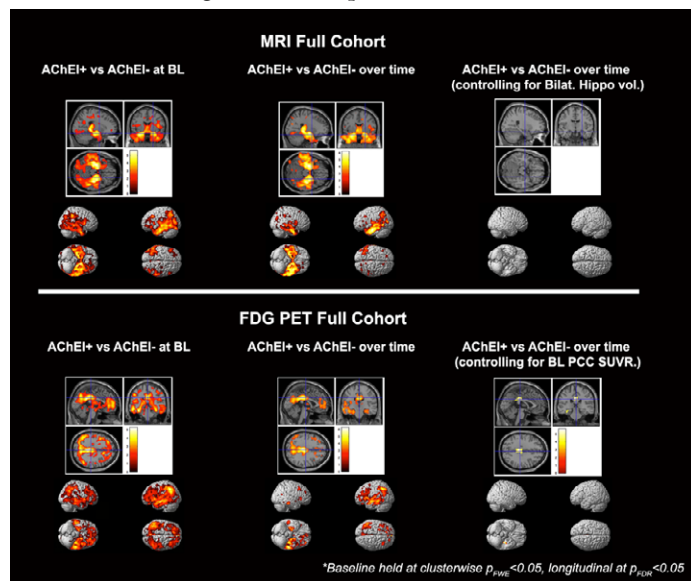
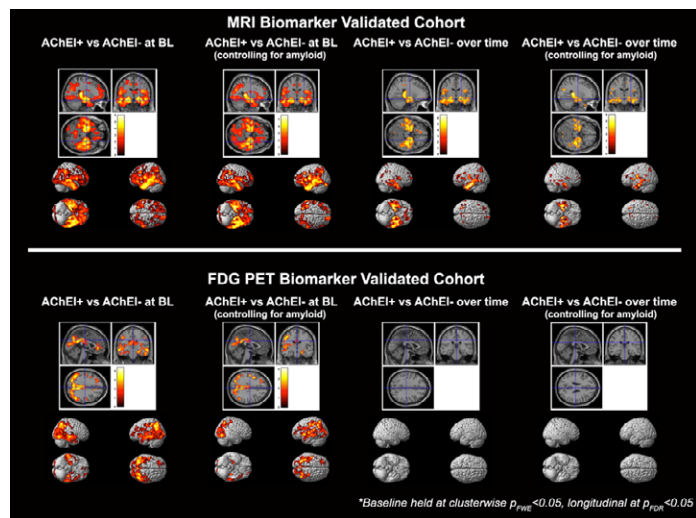

Figure 2
Significance maps for full cohort



Theme: Clinical trials: Biomarkers and including plasma

P1: SUSTAINED ATTENTION AND MEMORY TASKS WITH CONCURRENT EEG PROVIDE POTENTIAL BIOMARKERS FOR MILD COGNITIVE IMPAIRMENT.

Shani Waninger¹, Chris Berka¹, Amir Meghdadi¹, David Salat², Ajay Verma³ ((1) *Advanced Brain Monitoring, Inc., Carlsbad, CA*; (2) *MGH/MIT/HMS Athinoula A. Martinos Center for Biomedical Imaging, Department of Radiology, Massachusetts General Hospital, Charlestown, MA*; (3) *United Neuroscience, Dublin, Ireland*)

Background: There is a critical unmet need for reliable, cost effective and noninvasive biomarkers to quantify cognitive defects associated with dementia at early stages to facilitate development of efficacious, disease modifying therapeutics. Event-related potentials (ERPs) reliably measure the neurophysiology associated with cognition and may provide sensitive metrics for tracking disease progression and assessing efficacy of novel interventions for dementia. **Objective:** Reliable and sensitive EEG biomarkers are validated in a mild cognitive impairment (MCI) cohort compared to healthy cohort using tasks designed to elicit neural circuitry associated with cognitive process such as attention and memory. **Methods:** 3-Choice Vigilance (3CVT) and Standard Image Recognition (SIR) tasks were administered with concurrent EEG acquisition to elicit ERPs in MCI and healthy cohorts. EEG was filtered and independent component analysis applied. F-Measure, a combined measure of processing speed and accuracy, evaluated performance. Correlations between behavioral measures of performance and neurophysiologic measures were evaluated using Pearson's linear correlation. **Results:** There was significant suppression of the ERP waveform late positive component (LPC) in the MCI group compared to the healthy controls during 3CVT in occipital and right temporal-parietal region and during SIR with widespread suppression over central, temporal, parietal and occipital regions. F-measure in the MCI group was also suppressed compared to the healthy group in the SIR task. Strong and significant ($r > 0.5$ and $p < 0.01$) correlations were observed

between the SIR F-measures and LPC, particularly at T5, P3 and PZ channels. A recognition effect was observed in the healthy group indicating memory activation, however the effect were lost in the MCI group. **Conclusions:** The data suggest that cognitive ERPs obtained during tasks that activate the neural circuits involved in sustained attention and recognition memory provide a powerful tool for assessing dementia and have strong potential as sensitive and robust biomarkers for monitoring disease progression and evaluating response to investigative therapeutics.

P4: HIGH CORRELATION IN THE AB40 AND AB42 LEVELS IN HUMAN CEREBROSPINAL FLUID AS MEASURED BY ELISA AND HPLC-MS/MS. José A. Allué, Leticia Sarasa, Virginia Pérez-Grijalba, Noelia Fandos, Pedro Pesini, Manuel Sarasa (*Araclon Biotech S.L., Vía Hispanidad 21, 50.009, Zaragoza, Spain*)

Background: There is a critical unmet need for reliable, cost effective and noninvasive biomarkers to quantify cognitive defects associated with dementia at early stages to facilitate development of efficacious, disease modifying therapeutics. Event-related potentials (ERPs) reliably measure the neurophysiology associated with cognition and may provide sensitive metrics for tracking disease progression and assessing efficacy of novel interventions for dementia. **Objective:** Reliable and sensitive EEG biomarkers are validated in a mild cognitive impairment (MCI) cohort compared to healthy cohort using tasks designed to elicit neural circuitry associated with cognitive process such as attention and memory. **Methods:** 3-Choice Vigilance (3CVT) and Standard Image Recognition (SIR) tasks were administered with concurrent EEG acquisition to elicit ERPs in MCI and healthy cohorts. EEG was filtered and independent component analysis applied. F-Measure, a combined measure of processing speed and accuracy, evaluated performance. Correlations between behavioral measures of performance and neurophysiologic measures were evaluated using Pearson's linear correlation. **Results:** There was significant suppression of the ERP waveform late positive component (LPC) in the MCI group compared to the healthy controls during 3CVT in occipital and right temporal-parietal region and during SIR with widespread suppression over central, temporal, parietal and occipital regions. F-measure in the MCI group was also suppressed compared to the healthy group in the SIR task. Strong and significant ($r > 0.5$ and $p < 0.01$) correlations were observed between the SIR F-measures and LPC, particularly at T5, P3 and PZ channels. A recognition effect was observed in the healthy group indicating memory activation, however the effect were lost in the MCI group; **Conclusions:** The data suggest that cognitive ERPs obtained during tasks that activate the neural circuits involved in sustained attention and recognition memory provide a powerful tool for assessing dementia and have strong potential as sensitive and robust biomarkers for monitoring disease progression and evaluating response to investigative therapeutics.

P22: CEREBROSPINAL FLUID BIOMARKERS IN J-ADNI: DIAGNOSTIC ACCURACY IN AD AND PREDICTABILITY OF FUTURE CLINICAL CHANGE IN MCI. Kazushi Suzuki¹, Ryoko Ihara¹, Atsushi Iwata¹, Takeshi Iwatsubo¹, Kenji Ishii², Takeshi Ikeuchi³, Ryozo Kuwano³ Japanese Alzheimer's Disease Neuroimaging Initiative ((1) *The University of Tokyo, Tokyo, Japan*; (2) *Tokyo Metropolitan Institute of Gerontology, Tokyo, Japan*; (3) *Niigata University, Niigata, Japan*)

Background: Improvement of diagnostic accuracy of CSF biomarkers on Alzheimer's disease (AD) is important for clinical practice of dementia. Accurate prediction of future conversion from mild cognitive impairment (MCI) to AD is also essential for the efficient enrollment of "at-risk" MCI subjects in clinical trials. J-ADNI, the first large-scale multicenter observational study of the early stages of AD including MCI in the Asian population, was successfully completed and its dataset can provide a good model for the aged society in Japan. By utilizing data from MCI and AD of J-ADNI, we validated the diagnostic accuracy of CSF amyloid biomarker (CSF A β 1-42) and CSF neurodegenerative biomarkers (CSF total tau (t-tau) and phosphorylated tau (p-tau)) using the clinical and biomarker data of J-ADNI. We further analyzed the predictability of those biomarkers in cognitive/functional decline of MCI subjects applying validated cutoff values. **Methods:** The dataset of the J-ADNI (Research ID: hum0043.v1, 2016) was obtained from the National Bioscience Database Center (Tokyo, Japan). From J-ADNI dataset, 54 cognitively normal (CN), 88 MCI, and 55 AD subjects whose CSF biomarker data at baseline visit were available were selected. Diagnostic accuracy of the five CSF biomarkers and their combined indexes (A β 1-42, t-tau, p-tau, t-tau/A β 1-42, and p-tau/A β 1-42) were validated using area under curve (AUC) calculated by receiver operating characteristic (ROC) analysis. Optimal cutoff values were determined by Youden index, which maximizes the sum of sensitivity and specificity. Longitudinal cognitive changes of MCI subjects were evaluated by total score of Mini mental state examination (MMSE) and Alzheimer's Disease Assessment Scale-cognitive subscale 11 (ADAS-Cog11) at baseline, 6 months (M), 12M, 18M, 24M, and 36M. Clinical changes of MCI subjects were evaluated by score of Clinical dementia rating (CDR) sum of boxes at the same points. The occurrence of conversion to AD for three years was also compared using Kaplan-Meier method. Statistical analysis was performed by ANOVA and Tukey's post hoc test for grouped numerical data or Log-rank test for time-to-conversion data using JMP software. Missing values are excluded in each analysis. **Results:** First, the diagnostic accuracy of five CSF biomarkers for AD group was examined by ROC analysis using MCI/CN group as a control. Among 5 biomarkers, t-tau/A β 1-42 showed the highest AUC (0.77887). Second, to further improve the accuracy, similar analysis was performed only for subjects with baseline amyloid PET results available. The diagnostic accuracy of five CSF biomarkers for amyloid PET-positive AD/MCI group was examined using amyloid PET-negative CN group as a control. This analysis also proved the highest diagnostic accuracy of t-tau/A β 1-42 (AUC: 0.99225). Optimal cutoff value of each biomarker was separately determined in the first (cutoff 1) and second (cutoff 2) analysis by Youden index. To assess the predictability of each biomarker on future clinical changes, MCI subjects were divided into two groups by positivity of each biomarker (biomarker positive MCI and biomarker negative MCI) applying cutoff 1 and cutoff 2. Longitudinal changes of the scores of MMSE, ADAS-Cog11, and

CDR Sum of boxes were compared between the two groups. In the analysis of cutoff 1, t-tau/ A β 1-42 and p-tau showed good time-dependent separation of clinical outcome between biomarker positive MCI and biomarker negative MCI. In t-tau/ A β 1-42-positive MCI subjects, significant decrease in the MMSE score were observed at 6M (p=0.00423 at 6M). Similar tendency was observed in the analysis of cutoff 2, but the predictability of p-tau was further improved. MMSE score of p-tau positive MCI subjects significantly decreased at 12M (p=0.0006). We further analyzed the association between positivity of CSF biomarkers and time to AD conversion in MCI subjects using Log-rank test. Among the five CSF biomarkers, the most notable difference in time to conversion was observed in p-tau positive MCI and p-tau negative MCI (p=0.0007 in cutoff 1 and p=0.00008 in cutoff 2). **Conclusions:** t-tau/A β 1-42 showed the highest diagnostic accuracy of AD among the five CSF biomarkers we assessed. This result is generally consistent with the previous results on CSF biomarkers in AD. Meanwhile, p-tau is considered to be most predictable for future clinical changes in MCI subjects. This result might suggest that each biomarker shows different dynamics and that increase in p-tau is most prominent during the progression of MCI. We also presented the optimized cutoff value of CSF biomarkers in the Japanese population. These cutoffs values are most reliable in the prediction of clinical progression of MCI, based on an unprecedented large-scale dataset in the Japanese population combined with amyloid PET data.

P28: ANALYTICAL PERFORMANCE OF THE LUMIPULSE® G PTAU 181 AND LUMIPULSE® G B-AMYLOID 1-40 ASSAYS. Manu Vandijck, Martine Dauwe, Rosina Degrieck, Els Huyck, Nathalie Le Bastard, Geert Jannes, Vesna Kostanjevecki (*Fujirebio Europe NV, Ghent, Belgium*)

Background: Today levels of β -amyloid peptides (A β 1-42 and A β 1-40) and tau proteins (total Tau and hyperphosphorylated Tau) in cerebrospinal fluid (CSF) are well-accepted Alzheimer's disease (AD) biomarkers. Quantification of these analytes in CSF has proven to be of value in the diagnosis of AD and in distinguishing AD from other neurodegenerative dementias. Widespread use of these biomarkers requires reliable, highly precise, and accurate measurements. By completing the Lumipulse AD biomarker panel with assays for determination of pTau 181 and A β 1-40, a full core CSF AD biomarker portfolio becomes available. **Objectives:** Analytical performance of novel automated assays for quantification of pTau 181 and A β 1-40 (both assays under development) was evaluated according to CLSI guidelines, including a method comparison with INNOTEST®. **Methods:** The LUMIPULSE G instrument series use single, ready-to-use immunoreaction cartridges with a throughput of 60 and 120 tests/hour for the G600II and the G1200 instrument, respectively. Each cartridge generates quantitative results within approximately 30 minutes. The Lumipulse G pTau 181P and Lumipulse G β -Amyloid 1-40 assays were developed using established monoclonal antibodies. Analyte levels were determined on a set of CSF samples from patients visiting a memory clinic for a method comparison versus the respective INNOTEST assay. **Results:** Using a panel of CSF and control samples, assay variability was determined and the obtained coefficient of variation seen for the different variability components shows a high level of precision, which is expected for assays run on this automated platform. Using diluted low

concentrated CSF samples, a high analytical sensitivity for both assays could be demonstrated. Linearity was shown across the clinical application range. A method comparison study for both Lumipulse assays with INNOTEST resulted in a good correlation. **Conclusions:** Automation, the mono test cartridge principle, short throughput times, and instrument flexibility are key attributes of the LUMIPULSE G instrument series making it the ideal platform to fulfill today's needs for rapid and accurate quantification of CSF biomarkers. The novel Lumipulse G pTau 181P and Lumipulse G β -Amyloid 1-40 assays show good sensitivity and precision, and correlate well with the INNOTEST assays.

P30: CURCUMIN IS DETECTABLE IN HUMAN CEREBROSPINAL FLUID AFTER ORAL ADMINISTRATION OF TURMERIC EXTRACT HSRX-888. Norman Relkin¹, Dan Li², Joshua Costin², David Wyatt³ ((1) *Relkin Consulting LLC, Harrington Park, NJ 07640*; (2) *HerbalScience Group, Naples FL, USA*; (3) *Syneos Health, Miami FL, USA*)

Background: Turmeric and its derivative curcumin have beneficial properties for brain health including the potential to mitigate neurodegenerative disorders such as Alzheimer's disease. However, orally administered purified curcumin has notoriously poor bioavailability. Review of the peer-reviewed literature failed to identify any previous studies in which curcumin was detectable in human cerebrospinal fluid (CSF) following oral administration. The proprietary turmeric extract HSRx-888 was formulated to enhance bioavailability and bioactivity by maintaining a fixed ratio of curcumin to several other molecules that occur naturally in the turmeric rhizome. The primary goal of this study was to determine whether curcumin is detectable in the CSF of healthy humans who receive HSRx-888 orally. **Methods:** A total of six consenting healthy adults participated in this IRB-approved clinical trial conducted at a single site in the USA (Miami, FL). Each participant received a total of 19 doses of HSRx-888 by mouth over 7 days. Three participants were assigned to HSRx-888 350mg three times daily (total 1050mg/day) and another three participants received HSRx-888 525mg three times daily (total 1575 mg/day). For pharmacokinetic analyses, a venous blood sample was obtained immediately prior to the first dose and at multiple time points over the subsequent 8 hours. A lumbar puncture and one additional blood draw were performed on Day 7. Plasma samples were subjected to ethanol extraction without glucuronidase pre-treatment, and CSF specimens were examined neat. Free curcumin levels were determined by mass spectroscopy (DART Accu-TOF) using purified curcumin and salicylic acid standards. Safety and tolerability were assessed clinically. **Results:** Curcumin was detectable on Day 7 in the CSF of all six volunteers. The CSF curcumin concentration was in the nanomolar range and was higher on average in participants who received the 1575 mg/day HSRx-888 than in those taking 1050 mg/day. Other phytochemicals associated with HSRx-888 were also detected in the CSF of participants. Free curcumin was found in the blood of all six volunteers within the first 30 minutes of initial HSRx-888 ingestion. The C_{max} in blood after the first dose was in the nanomolar range and remained above baseline for up to eight hours. All subjects showed good tolerance and no adverse events related to HSRx-888 were reported. **Conclusion:** HSRx-888 is the first turmeric extract proven to deliver curcumin into the cerebrospinal fluid

of healthy normal volunteers after oral administration. HSRx-888 was safe and well-tolerated at doses up to 1.575 grams a day. Further studies of this promising phytochemical extract are warranted, including clinical trials for neurodegenerative, neurotraumatic and other disorders of the central nervous system.

P39: DIAGNOSTIC BIOMARKERS' CLINICAL APPLICABILITY IN EARLY ONSET ALZHEIMER'S DISEASE. Neus Falgàs¹, Raquel Sánchez-Valle¹, Mircea Balasa^{1,2}, Sergi Borrego¹, Magdalena Castellví¹, Adrià Tort-Merino¹, Jaume Olives¹, Beatriz Bosch¹, Guadalupe Fernández¹, Francisco Lomeña³, Núria Bargalló⁴, Albert Lladó¹ (1) *Alzheimer's disease and other cognitive disorders Unit. IDIBAPS. Hospital Clínic de Barcelona;* (2) *Atlantic Fellow for Equity in Brain Health. Global Brain Health Institute. Trinity College Dublin, Ireland;* (3) *Nuclear Medicine Department. IDIBAPS. Hospital Clínic de Barcelona;* (4) *Image Diagnostic Centre. IDIBAPS. Hospital Clínic de Barcelona*

Background: Although Alzheimer's disease (AD) typical clinical profile presents with anterograde episodic memory impairment, non-amnesic clinical presentations are commonly seen in early onset AD (EOAD). Clinical features frequently overlap with other neurodegenerative dementias such as frontotemporal dementia (FTD) or non-neurodegenerative conditions such as psychiatric disorders. This diagnostic complexity frequently leads to greater rates of misdiagnosis and diagnostic delay in EOAD. In this context AD diagnostic biomarkers are useful on the diagnosis, especially in prodromal and mild stages. Nowadays, there are different AD diagnostic biomarkers, including amyloid deposition biomarkers: amyloid β 42 level determination on cerebrospinal fluid (CSF) and amyloid-Positron Emission Tomography (PET), and neurodegenerative biomarkers: tau determination on CSF, medial temporal atrophy (MTA) visual assessment on magnetic resonance imaging (MRI) and fluorodesoxyglucose (FDG)-PET. In the clinical practice the diagnostic biomarker election for each case depends, not only on its availability, but also on other factors as the tests patient's tolerance and the grade of diagnosis' confidence that each test adds to the neurologist's clinical diagnostic suspicion. **Methods:** We included forty subjects who consulted on Hospital Clínic Alzheimer's disease and other cognitive disorders Unit for early onset cognitive problems (<65 years). On the first visit, neurological clinical evaluation and MMSE screening test were performed. The neurologist filled in a questionnaire with the initial clinical diagnosis and its degree of confidence using a 0 to 100% scale. Then, the neuropsychological battery (NPB), lumbar puncture (LP) to AD CSF biomarker analysis, medial temporal atrophy visual assessment on brain MRI, amyloid-PET and FDG-PET were done. After biomarker results, the neurologist was asked to provide the patient's final diagnosis and the confidence of diagnosis for each biomarker. Information about therapeutic management and follow-up was asked as well. On the other hand, patients filled in a questionnaire in which they reported the perceived grade of invasiveness for each test by numerical scale. They were also asked about the reason for the inconvenience and if they should repeat the test if it was necessary. **Results:** The 57% of the sample were men with a mean age of 59 (SD 4,2) years old, mean age of symptom onset 56,8 (5,4) and mean MMSE score of 23,7 (SD 3,6). 20% of LP were not done due to contraindication, technical

difficulties or patient consent withdrawal. 5% of FDG-PET were not interpretable due to hyperglycemia. In AD patients, the level of diagnostic confidence increased about 17% with AD CSF biomarker and 21% with amyloid-PET. Both biomarkers increased the diagnostic confidences more than FDG-PET and MTA assessment ($p < 0,01$). The use of biomarkers entailed to a diagnosis change on 9 patients (28%): 3 changes from AD to a non-neurodegenerative cognitive impairment, 3 changes from non-degenerative cognitive disorder to AD, 2 changes from AD to FTD, and 1 from non-neurodegenerative cognitive impairment to FTD. The patients' perceived invasiveness showed no significant differences between the different tests. However, NPB and LP showed higher percentage of mild-moderate inconvenience: 37% on NPS, mostly due to anxiety and 41% on LP, due to anxiety, local pain during or headache after the procedure. The MRI had the higher percentage of severe annoyance (13%, mostly due to claustrophobia) and up to 7% of patients would withdrawal consent if they were asked to repeat the MRI. **Conclusion:** Diagnostic biomarkers increase the diagnostic confidence in EOAD, especially in the case of CSF analysis and amyloid-PET and all of them have good patient's tolerance. Furthermore, in our cohort the use of biomarkers led to a diagnosis change on 28% of patients. These data together suggest that biomarkers are helpful to determine the patient diagnosis, with direct implications in the clinical and therapeutic management of these patients.

P44: INVERSE ASSOCIATION BETWEEN AB42/40 PLASMA RATIOS AND FIBRILLARY AMYLOID DEPOSITION IN THE BRAIN: RESULTS OF THE FACEHBI STUDY. Itziar de Rojas¹, Judith Romero², Octavio Rodríguez-Gomez¹, Pedro Pesini², Angela Sanabria¹, Alba Pérez-Cordon¹, Carla Abdelnour¹, Isabel Hernández¹, Maitte Rosende-Roca¹, Ana Mauleón¹, Liliana Vargas¹, Montserrat Alegret¹, Ana Espinosa¹, Gemma Ortega¹, Silvia Gil¹, Marina Guitart¹, Anna Gailhagane¹, Miguel Angel Santos-Santos¹, Sonia Moreno-Grau¹, Oscar Sotolongo-Grau¹, Susana Ruiz¹, Laura Montreal¹, Elvira Martín¹, Esther Pelejà¹, Francisco Lomeña³, Francisco Campos³, Assumpta Vivas⁴, Marta Gómez-Chiari⁴, Miguel Angel Tejero⁴, Joan Giménez⁴, Virginia Pérez-Grijalba², Marta Marquíe¹, Gemma Monté-Rubio¹, Sergi Valero¹, Adelina Orellana¹, Lluís Tàrraga¹, Manuel Sarasa², Agustín Ruiz¹, Mercè Boada¹, on behalf of the FACEHBI study (1) *Research Center and Memory Clinic. Fundació ACE. Institut Català de Neurociències Aplicades, UIC-Barcelona, Spain;* (2) *Araclon Biotech©. Zaragoza, Spain;* (3) *Servei de Medicina Nuclear, Hospital Clínic i Provincial. Barcelona, Spain;* (4) *Departament de Diagnòstic per la Imatge. Clínica Corachan, Barcelona, Spain*

Background: Peripheral biomarkers identifying individuals at risk of developing Alzheimer's disease (AD) or predicting high amyloid beta ($A\beta$) brain burden would be highly valuable. To facilitate clinical trials of disease-modifying therapies, plasma concentrations of $A\beta$ species are good candidates for peripheral biomarkers, but studies to date have generated conflicting results. **Objectives:** The primary aim of this study was to assess the association between plasma $A\beta$ and brain $A\beta$ (FBB-PET). Subsequently, we evaluated the usefulness of blood biomarkers as a screening tool in AD. **Methods:** The FACEHBI study uses a convenience sample of 200 individuals diagnosed with subjective cognitive decline (SCD) at Fundació ACE (Barcelona, Spain) who underwent amyloid florbetaben(18F) (FBB) PET brain imaging. Baseline

plasma samples from FACEHBI subjects (age 65.9 ± 7.2) were analyzed using ABtest (Araclon Biotech). This test directly determines the free (FP) and total (TP) plasma levels of A β 40 and A β 42 peptides. The association between A β 40 and A β 42 plasma levels and FBB-PET global SUVR was determined using correlations and linear regression-based methods. The effect of APOE genotype on plasma A β levels and FBB-PET was also assessed. Finally, various models including different combinations of demographic, genetic, and A β plasma levels were constructed using logistic regression and area under the receiver operating characteristic curve (AUROC) analyses to evaluate their ability of discriminating which subjects presented β -brain amyloidosis. **Results:** FBB-PET global SUVR correlated weakly but significantly with A β 42/40 plasma ratios. For TP42/40, this observation persisted after controlling for age and APOE ϵ 4 allele carrier status [$R^2=0.193$, $p=1.01E-09$]. The ROC-curve demonstrated that plasma A β measurements are not superior to APOE and age in combination. However, the highest sensitivity (83%) was achieved by a model that only included TP42/40 level as a predictor variable (Table 1). It is noteworthy that a simple pre-selection step using the TP42/40 classifier with an empirical cut-off value of 0.08 would reduce the number of individuals subjected to A β FBB-PET scanners by 48.7% (Figure 1). No significant dependency was observed between APOE genotype and plasma A β measurements (p -value for interaction = 0.105). **Conclusion:** Brain and plasma A β levels are partially correlated in individuals diagnosed with SCD. A β plasma measurements, particularly the TP42/40 ratio, could generate a new recruitment strategy independent of the APOE genotype that would improve identification of SCD subjects with brain amyloidosis and reduce the rate of screening failures in pre-clinical AD studies. Independent replication of these findings is warranted. Keywords: Subjective cognitive decline, Preclinical AD, Alzheimer's disease, Amyloid β , plasma biomarker, TP42/40, PET, Florbetaben.

Figure 1

Linear regression between FBB-PET global SUVR and A β TP42/40 plasma ratio in SCD subjects

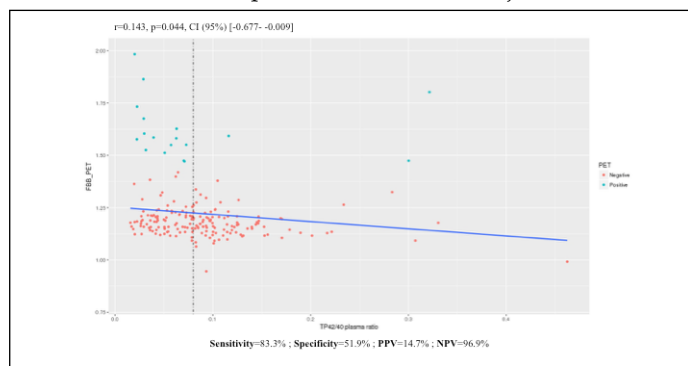

Inverse association between A β TP42/40 plasma ratio and FBB-PET scan. Experimental cut-off point of A β plasma ratio TP42/40 established at 0.08 to reduce the pre-screening number of A β FBB-PET scans by 48.7%.

Table 1

Summary of logistic regression models and AUROC analysis.

Characteristic	Model 1		Model 2a		Model 2b		Model 3		Model 4	
	OR (95% CI)	P	OR (95% CI)	P	OR (95% CI)	P	OR (95% CI)	P	OR (95% CI)	P
Age	1.091 (1.016-1.172)	0.017	1.114 (1.033-1.202)	0.005	1.097 (1.017-1.183)	0.017	1.113 (1.029-1.205)	0.008	-	-
APOE	-	-	7.319 (2.503-21.401)	2.8E-04	-	-	7.208 (2.431-21.373)	3.7E-4	-	-
L_TP42/40	-	-	-	-	0.131 (0.021-0.819)	0.030	0.126 (0.017-0.944)	0.044	0.133 (0.021-0.829)	0.031
AUROC	0.702		0.806		0.754		0.818		0.681	
Youden's index	0.42		0.54		0.49		0.55		0.42	
Cut-off	0.101		0.147		0.115		0.092		0.081	
Specificity	69.6		87.3		76.8		77.3		59.1	
Sensitivity	72.2		66.7		72.2		77.8		83.3	
PPV	19.1		34.3		23.6		25.5		16.7	
NPV	96.2		96.3		96.5		97.2		97.2	

P57: CONCORDANCE OF THE CSF ABETA42/ABETA40 RATIO WITH AMYLOID-PET IN THE BIOFINDER STUDY.

Oskar Hansson^{1,2}, Katharina Zink³, Simone Wahl³, Monika Widmann⁴, Sandra Rutz³, Maryline Simon⁵, Kaj Blennow^{6,7}, Erik Stomrud^{1,2} (1) Clinical Memory Research Unit, Lund University, Malmö, Sweden; (2) Memory Clinic, Skåne University Hospital, Malmö, Sweden; (3) Centralised & Point of Care Solutions, Roche Diagnostics GmbH, Penzberg, Germany; (4) Centralised & Point of Care Solutions, Roche Diagnostics GmbH, Mannheim, Germany; (5) Centralised & Point of Care Solutions, Roche Diagnostics International, Rotkreuz, Switzerland; (6) Clinical Neurochemistry Laboratory, Sahlgrenska University Hospital, Mölndal, Sweden; (7) Institute of Neuroscience and Physiology, Dept. of Psychiatry and Neurochemistry, The Sahlgrenska Academy at University of Gothenburg, Mölndal, Sweden)

Background: Amyloid- β plaques are a neuropathological hallmark of Alzheimer's disease (AD), and CSF amyloid- β (1-42; Abeta42) has demonstrated utility as a diagnostic and prognostic biomarker in patients with cognitive impairment. The ratio of CSF Abeta42/amyloid- β (1-40; Abeta40) may be a more robust measure compared with Abeta42 alone due to the inter-individual variability in amyloid- β levels.

Objectives: To evaluate concordance between CSF Abeta42/Abeta40 and amyloid-PET, and compare the performance of CSF Abeta42/Abeta40 against Abeta42, and phosphorylated (181P) tau (pTau)/Abeta42 and total tau (tTau)/Abeta42 ratios.

Methods: CSF samples used in the analysis were collected as part of the prospective Swedish BioFINDER study; patients were classified into subgroups based on results from extensive neuropsychological assessment. The main analysis cohort comprised 277 patients with valid CSF Abeta42 and Abeta40 measurements, an 18F-flutemetamol PET reading at baseline, and mild cognitive symptoms (MCS, n=277: subjective cognitive decline [SCD], n=120; mild cognitive impairment [MCI], n=153; unknown sub-classification, n=4). Additional analyses were conducted in 728 patients from the cohorts normal cognition (NC), SCD, MCI and AD, with at least one valid CSF biomarker measurement (Abeta42, Abeta40, pTau and tTau), with/without an 18F-flutemetamol PET reading. Baseline CSF concentrations of Abeta42, Abeta40, pTau and tTau were measured using Elecsys® CSF immunoassays (Elecsys® CSF Abeta40 assay is currently for research use only). For each CSF biomarker (Abeta42, Abeta42/Abeta40, pTau/Abeta42 and tTau/Abeta42) receiver operating characteristic (ROC) analyses

were conducted and area under the curves (AUCs) with 95% confidence intervals (CIs) derived. Differences between the AUCs were evaluated using DeLong test. Concordance between biomarker classifications and amyloid-PET (positive/negative) was assessed, using cut-offs optimized for concordance and robustness in all analyses, and percentage agreements calculated. **Results:** When determining amyloid status (using 18F-flutemetamol as reference) in MCS patients, similar AUCs were found for the ratios Abeta42/Abeta40 (92.8% [89.5–96.2%]), pTau/Abeta42 (94.4% [91.5–97.3%]) and tTau/Abeta42 (94.0% [91.0–97.0%]); all ratio AUCs were significantly higher compared with Abeta42 alone (86.5% [82.3–90.7%]; all $p < 0.001$). Good separation was observed between amyloid-PET-positive and -negative patients in the two-dimensional CSF biomarker spaces, whereby clusters were more distinct for pTau (or tTau) versus Abeta42 than for Abeta40 versus Abeta42 (Figure). Using the chosen robust cut-offs, Abeta42/Abeta40 and Tau/Abeta42 ratios demonstrated similarly good overall concordance with PET, with higher positive and lower negative percentage agreement observed for Abeta42/Abeta40. In the NC cohort, the ratios pTau/Abeta42 (AUC: 94.9% [90.8–99.1%]) and tTau/Abeta42 (AUC: 94.7% [90.2–99.1%]) performed significantly better than Abeta42 alone (92.2% [85.7–98.6%]; $p < 0.001$) when determining amyloid-PET status. The ratio Abeta42/Abeta40 (AUC: 94.4% [89.5–99.2%]) had a higher AUC, but was not significantly better than Abeta42 alone ($p = 0.337$). The ratios also performed better when separating the NC versus AD cohorts, AUCs (95% CI) were: Abeta42/Abeta40, 89.6% (85.5–93.7%); pTau/Abeta42, 93.5% (90.2–96.9%); tTau/Abeta42, 93.6% (90.3–97.0%); and Abeta42 alone, 88.6% (84.4–92.9%). Significant differences in AUC for both Tau/Abeta42 ratios compared with Abeta42 were observed ($p < 0.001$). Although Abeta42/Abeta40 had a higher AUC compared with Abeta42 alone, the difference was not significant ($p = 0.572$). **Conclusion:** High concordance was observed between Elecsys® CSF Abeta42/Abeta40 and amyloid-PET. Abeta42/Abeta40 demonstrated improved performance compared with Abeta42 but showed no overall superiority compared with Tau/Abeta42 ratios. Abeta42/Abeta40 may be a promising CSF biomarker to aid in AD diagnosis and identifying patients for AD clinical practice and trials.

Figure

Distribution of the CSF biomarkers colored by amyloid-PET visual read classification: (A) Elecsys® Abeta42/Abeta40, (B) Elecsys® pTau/Abeta42, in the main analysis cohort

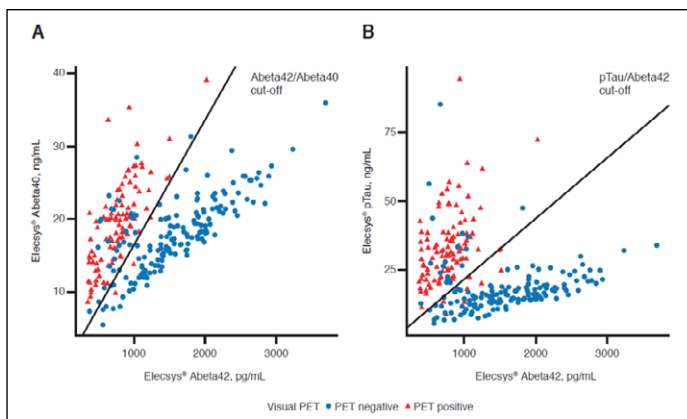

P64: NOVEL PRE-ANALYTICAL PROTOCOL FOR HANDLING OF CEREBROSPINAL FLUID SAMPLES FOR THE ANALYSIS OF ALZHEIMER'S DISEASE BIOMARKERS IN CLINICAL PRACTICE. Oskar Hansson^{1,2}, Erik Stomrud^{1,2}, Sandra Rutz³, Valeria Lifke³, Ekaterina Bauer³, Udo Eichenlaub³, Richard Batrla⁴, Ekaterina Manuilova⁴, Mehmet Can Mert⁴, Simone Wahl⁴, Kaj Blennow^{5,6} ((1) *Clinical Memory Research Unit, Lund University, Malmö, Sweden*; (2) *Memory Clinic, Skåne University Hospital, Malmö, Sweden*; (3) *Centralised & Point of Care Solutions, Roche Diagnostics GmbH, Penzberg, Germany*; (4) *Centralised & Point of Care Solutions, Roche Diagnostics International, Rotkreuz, Switzerland*; (5) *Clinical Neurochemistry Laboratory, Sahlgrenska University Hospital, Mölndal, Sweden*; (6) *Institute of Neuroscience and Physiology, Dept. of Psychiatry and Neurochemistry, The Sahlgrenska Academy at University of Gothenburg, Mölndal, Sweden*)

Background: The core AD CSF biomarkers (Abeta42, Abeta40, pTau and tTau) can be used to identify AD-related pathology. Improvements in immunoassays have resulted in higher precision and lower between-laboratory variations. CSF samples are currently handled differently across studies and clinical sites, and pre-analytical factors are known to affect measured AD CSF biomarker levels. Accordingly, a unified and standardized pre-analytical protocol is required, to be used by both academia and industry. A unified pre-analytical protocol will, together with high-precision assays, serve as the basis to introduce global cut-offs for AD CSF biomarkers, and encourage their use in both clinical research and routine clinical practice. **Objectives:** To assess the impact of pre-analytical factors on the measurement of CSF biomarker concentration levels, and to develop a simplified CSF handling protocol for AD CSF biomarker testing, starting with lumbar puncture and ending with a fully automated instrument. **Methods:** In all experiments, the following procedure was used as reference: CSF was dripped from a lumbar puncture needle directly into a novel LowBind false bottom tube (FBT; developed for this purpose by Sarstedt) and analyzed on the Elecsys® assay, within several hours without any further handling steps. The impact of different pre-analytical factors (including tube type, tube transfer steps/pipetting, tube filling volume, mixing procedure, lumbar puncture procedure, and temperature/freeze-thaw cycles) was assessed with frozen and fresh CSF samples. These pre-analytical evaluations, and previously published data on this topic, will form the basis for a novel simplified pre-analytical protocol for handling of CSF samples for AD biomarker testing, which will be developed in collaboration with the CSF Pre-Analytical Working Group and Alzheimer's Association. **Results:** Preliminary data show that Abeta42 in fresh samples was stable for ≤ 7 days at room temperature, and ≤ 14 days at 4°C. Similar results were obtained for Abeta40, pTau and tTau. Several pre-analytical factors (including mixing procedure, tube type and tube filling volume) had an impact on the measured analyte concentration, in particular Abeta42. The average and variability of measured Abeta42 concentrations were affected by the tube filling volume; the recommended range was determined as 1.5–2.0 mL. Similar but weaker volume effects were observed for Abeta40 compared with Abeta42. No volume effects were observed for tTau or pTau. Mixing procedure had a pronounced effect on measured Abeta42 concentration and a slightly weaker impact on Abeta40. We will present these and further data contributing to the development of a novel simplified pre-analytical protocol for handling of

CSF samples for AD biomarker analysis in clinical practice. **Conclusions:** A novel, simplified CSF pre-analytical protocol with the newly developed LowBind FBT is recommended for AD biomarker analysis on the Elecsys® analyzer in clinical practice to reduce the impact of pre-analytical factors and allow comparison of AD CSF biomarker results across studies and laboratories. The present work will contribute to the aim of reaching consensus on a pre-analytical protocol for handling CSF samples, for broad use by companies, academia and healthcare organizations.

P65: SERUM-BASED PROTEINS AS NOVEL BIOMARKERS FOR THE DIAGNOSIS OF ALZHEIMER'S DISEASE.

Shu Yu¹, Yue-Ping Liu² ((1) *State Key Laboratory of Military Stomatology and National Clinical Research Center for Oral Disease and Shaanxi Clinical Research Center for Oral Disease, Department of Laboratory Medicine, School of Stomatology, Fourth Military Medical University, Xi'an, Shaanxi Province 710000, China*; (2) *Department of Laboratory Medicine, 477th Hospital of PLA, Xiangyang, Hubei Province 400013, China*)

Background: Alzheimer's disease (AD) typically affects individuals who are aged 60 or above and is quickly becoming one of the most prevalent neurodegenerative disease worldwide. Thus, a non-invasive serum-based biomarker-based diagnostic platform is eagerly awaited. The goal of this study was to identify a serum-based biomarker panel using a predictive protein-based algorithm that is able to confidently distinguish AD patients from control subjects. **Methods:** One hundred and fifty six patients with AD and the same number of gender- and age-matched control participants with standardized clinical assessments and neuroimaging measures were evaluated. Serum proteins of interest were quantified using a magnetic bead based immunofluorescent assay and a total of 33 analytes were determined. All of the subjects were then randomized into a training set and a validation set in a proportion of 70%: 30%. Logistic regression and Random Forest analysis were then applied to develop a desirable algorithm for AD detection. **Findings:** Of the 33 analytes examined, 17 were found to be significantly differentially expressed between AD and control samples. The Random Forest method was found to generate a more robust predictive model than using the logistic regression analysis. Furthermore, an 8-protein-based algorithm was found to be the most robust with a sensitivity of 97.7%, specificity of 88.6%, and AUC of 99%. **Conclusion:** This study identified a total of 17 potential serum-based AD biomarkers, with 8 of these potential biomarkers ultimately selected following the construction of a novel 8-protein-based algorithm using the Random Forest method. Furthermore, the developed 8-protein biomarker panel was shown to have desirable sensitivity and specificity, thus suggesting applicability when developing an AD diagnostic. It is hoped that these results provide further insights into the applicability of serum-based screening methods and contribute to the development of lower cost, less invasive methods for diagnosing AD and monitoring progression. **Key words:** Alzheimer's disease, Diagnosis, serum protein-based profiles, Novel biomarkers

P66: TREM2 DNA METHYLATION: A POTENTIAL BIOMARKER OR THERAPEUTIC TARGET. Lynn Bekris¹, Rumana Akhter¹, Yvonne Shao¹, Maria Khrestian¹, Giana D'Aleo¹, Shane Formica¹, James B. Leverenz² ((1) *Genomic Medicine Institute, Lerner Research Institute, Cleveland Clinic, Cleveland, Ohio*; (2) *Cleveland Clinic Lou Ruvo Center for Brain Health, Cleveland Clinic, Cleveland, Ohio*)

Genetic variation in triggering receptor expressed on myeloid cells 2 (TREM2) is associated Alzheimer's disease (AD) and plays a role in neuroinflammation in AD mouse models. The soluble cleavage product of TREM2 (sTREM2) is elevated in AD cerebrospinal fluid (CSF), but not plasma, compared to cognitively normal controls, suggesting that cleavage or regulation of TREM2 differs in the periphery compared to the central nervous system. In our previous study a significant correlation between plasma sTREM2 levels and CSF sTREM2, as well as an association between CSF sTREM2 and a marker of blood brain barrier integrity, was observed in AD, suggesting a potential role of peripheral TREM2 in central TREM2 biology. Notably, TREM2 mRNA has been described as elevated in AD hippocampus and positively correlated with TREM2 methylation. However, in the AD brain the secretase responsible for the cleavage of TREM2, ADAM10, is low in AD implicating gene regulation as a potential critical player in the elevation of TREM2 levels in the brain. In contrast, while peripheral leukocyte TREM2 expression is also elevated in AD, it is negatively correlated with TREM2 methylation and TREM2 methylation is decreased in AD compared to controls. Given these previous findings, it was hypothesized that methylation of the whole blood TREM2 DNA locus; 1) is decreased in AD compared to cognitively normal controls, 2) negatively correlates with plasma sTREM2 levels and 3) changes as AD progresses. Blood samples were obtained from the Cleveland Clinic Lou Ruvo Center for Brain Health Aging and Neurodegeneration Biobank and included n=23 cognitively normal controls and n=26 AD patients. DNA and plasma were extracted and genomic DNA underwent bisulfite conversion using the EZ DNA Methylation Kit. Samples were loaded and hybridized onto Infinium HumanMethylation450 BeadChip. Plasma soluble TREM2 (sTREM2) was measured using the Luminex System and a custom capture sandwich immunoassay designed to detect the soluble portion of TREM2 protein. We found that whole blood DNA methylation at the TREM2 extended locus differs extensively by region, but only marginally differs by disease status. However, in AD and MCI, but not controls, DNA methylation in the TREM2 promoter and 5' region significantly correlated with plasma sTREM2 levels. Additionally, whole blood DNA methylation at the TREM2 promoter is significantly higher in AD after one year, but not does not change over time in cognitively normal controls. These findings suggest that in AD TREM2 methylation influences plasma sTREM2 levels and changes overtime in the periphery. Given the previously reported correlation between plasma and CSF sTREM2 in AD, TREM2 methylation may represent a potential therapeutic target in AD. This finding is important because it will allow us to identify factors that regulate TREM2 expression. Furthermore, changes in peripheral TREM2 methylation may represent a potential biomarker of AD progression or a potential therapeutic target to modulate inflammation in AD.

P73: IMMUNE STATE IN COGNITIVE IMPAIRMENT OF AGED AND THE USE OF ACTOVEGIN AND CERAXONE IN OUT-PATIENTS OF ALZHEIMER'S CENTRE. Nataliya Mikhaylova¹, Lubov Androsova² ((1) *Geriatric psychiatry Department, Mental health research centre, Moscow, Russia*; (2) *Immunology laboratory, Mental health research centre, Moscow, Russia*)

Background: There are some evidences of an important role of neuroinflammation in pathogenesis of dementia and effectiveness of neurometabolic treatment in various forms of cognitive impairment in aged. **Objectives:** They were to study the complex of immune markers in mild cognitive impairment (MCI) and main forms of old age dementia and to assess the effectiveness of Actovegin and Ceraxone use in observational out-patient study. **Patients and methods:** Data for study were obtained on out-patients of Moscow Alzheimer's centre. The diagnostic distribution of 2626 patients firstly admitted to out-patient Alzheimer's center from 2007 to 2016 showed mild cognitive impairment (MCI) in 21%; Alzheimer's disease (AD) in 38.1%, mixed dementia (MD) in 27.2%, vascular dementia (VaD) in 2.5%, others types of dementia (Frontotemporal dementia, Dementia with Lewy bodies, Parkinson's disease with dementia) in 8.1% and non-cognitive disorders in 3.1%. The MCI was diagnosed according to the criteria of R.S. Petersen. The diagnosis of AD was established in accordance with the ICD-10 and NINCDS-ADRDA criteria. The degree of dementia severity was determined by clinical assessment using the CDR (Clinical Dementia Rating) and the Mini mental state examination (MMSE) total score. Immune and biochemical parameters were determined in blood plasma. A sample of patients given informed consent for the study of innate immunity consisted of 67 patients with MCI, 101 patients with AD, 23 people with VaD and 63 patients with MD. The control group included 38 individuals, comparable to the patients of the examined groups as to their age and sex. The activity of LE and α 1-PI were determined by spectrophotometric method. The concentrations of IL-6 and CRP were established by the enzyme immunoassay. **Results:** Significantly high activity of α 1-PI was detected in all study groups. AD was characterized by significant decrease of LE activity.

P78: MODIFIABLE ALZHEIMER'S RISK BIOMARKERS. Christine Ganzer¹, Alon Seifan², Krista Ryon³, Elizabeth Maiche⁴ ((1) *Hunter College, NY*; (2) *NeuroWell Free, Ft. Lauderdale, Florida*; (3) *Hunter College, NY*; (4) *NeuroWell Free, Ft. Lauderdale, Florida*)

Background: Young people have modifiable risk factors for Alzheimer's disease (AD). Personalized interventions to reduce risk factors in mid-life are easy to implement and widely available. The extent of modifiable AD risk in younger populations seeking neurological or psychiatric care remains unknown. This is a critical research gap because people with behavioral health disorders are often excluded from most clinical research trials. Moreover, clinical care for behavioral health is often fragmented from medical care. The objective of this study was to characterize modifiable Alzheimer's disease risk in a population of patients seeking care for a wide range of behavioral health diagnoses in the NeuroWell Free patient centered neuropsychiatry specialty practice. **Methods:** In this observational, IRB approved study known as comparative effectiveness dementia and Alzheimer's registry (CEDAR), real world modifiable AD risk using factors selected from validated

risk indices is characterized. Risk was classified for each patient as optimal or low risk, moderate risk and at risk or high. The following biomarkers were included in the assessment: hemoglobin A1C, adiponectin, cystatin C, C-reactive protein, homocysteine, vitamin B12, and vitamin D. Clinical diagnosis was by a fellowship-trained behavioral neurologist and corroborated using DSM V criteria. Age, gender, ethnicity and education were collected using the NIH Toolbox standardized registration page. Socioeconomic status was approximated using the patients' health insurance plan type. We hypothesized that a significant portion of patients would exhibit moderate modifiable risk in mid-life. This hypothesis was based on the literature demonstrating increased prevalence of cardiovascular disease risk factors in patients with behavioral health disorders. Better characterization of economically modifiable risk in patients with neurological and psychiatric disorders will enable the design of cost effective disease modifying intervention. Development of such interventions is a paramount and current public health priority for Alzheimer's disease. **Results:** A total of 247 subjects were enrolled in this study. The mean age was 44 years, with 133 females and 114 males. Subject's that fell into the optimal category as follows: homocysteine were 76%, C - reactive protein 31%, Vitamin B12 84%, Vitamin D 42%, adiponectin 17%, hemoglobin A1C 63% and cystatin-c 82%. The percentage of all patients carrying moderate modifiable risk factor we found C-reactive protein 37%, Vitamin D 33%, adiponectin 23%, hemoglobin A1c 30% and cystatin-c 5%. In the at risk category subjects presented as follows: homocysteine 23%, C-reactive protein 30%, Vitamin B12 15%, Vitamin D 23%, adiponectin 58%, hemoglobin A1C 5% and cystatin-c 12%. **Conclusions:** Modifiable risk for AD is common in community based behavioral health clinics. Next steps for this research must include measurements of the cost required to reduce this risk for all behavioral health patients in all socioeconomic levels throughout the life course.

P81: SERUM NFL, TAU, GFAP AND UCHL-1 IN ALZHEIMER DISEASE PATIENTS WITH DIFFERENT DECLINE PROFILE. Méliissa Jacob^{1,2,3}, Aleksandra Maceski³, Stiene Rickaert³, Audrey Gabelle^{1,2,4}, Sylvain Lehmann^{2,3} ((1) *Memory Research and Resources Center, Department of Neurology, Montpellier University Hospital, Montpellier, France*; (2) *Université de Montpellier, MUSE, Montpellier, France*; (3) *Inserm U1183 IRMB, Montpellier, France*; (4) *Inserm U1061, La Colombière Montpellier University Hospital, Montpellier, France*)

Background: Prognosis biomarkers are needed to determine cognitive decline slope of neurodegenerative disorders. One potential blood biomarker for cognitive prognosis of Alzheimer disease (AD) is the neuronal injury marker called neurofilament light chain (NFL). Several studies already observed that NFL Plasma was increased in patients with MCI and AD compared with controls. NFL concentration was apparently also increased in the early clinical stage of AD suggesting that it is an interesting marker for the conversion of MCI in AD. **Objectives:** We hypothesized that serum NFL could be used for decline prognosis in AD. We also decided to study in parallel others biomarkers like Tau involved in AD, Glial fibrillary acidic protein (GFAP); the main astrocytic intermediate filament which has a different expression patterns in neurological diseases, and the ubiquitin-proteasome pathway, UCHL1, knowing the several studies have demonstrated the impairment of the proteasome in AD. **Methods:** We explored the serum value

of NFL, Tau, GFAP and UCHL-1 with ultrasensitive single-molecule array (Simoa) using a commercial kit called neuro 4-PLEX. The population included healthy controls (HC, n=11), slow progression of AD (n=24) characterized by less than 2 points of the MMSE test during one year, and fast AD cognitive decliners (n = 24) defined as a loss of more than 4 points of MMSE score in one year. An initial assessment was carried out with cognitive evaluation, brain MRI, lumbar puncture, blood samples taken between 2007 and 2013. The patients slow and fast decline patients had a MMSE score equivalent at the time of blood collection. **Results:** Serum NFL, Tau, GFAP concentrations were higher both in the slow progression AD dementia group with NFL=24.07 pg/ml (p=0.019), Tau=0.66 pg/ml (p=0.02), GFAP= 297.88 pg/ml (p=0.001) and in the fast AD cognitive decliners group with NFL=25.45 pg/ml (p=0.004), Tau=0.68 pg/ml (p=0.006), GFAP= 280.33 pg/ml (p=0.0023) when compared with control participants NFL=14.95 pg/ml, Tau=0.41 pg/ml, and GFAP= 141.17 pg/ml. There was no significant difference in UCHL-1 concentration between slow progression AD dementia group with UCHL-1=4.97 pg/ml (p=0.26), and fast AD cognitive decliners group with UCHL-1=8.35 pg/ml (p=0.9) compared with control participants with UCHL-1=8.31 pg/ml. Importantly, we found no significant differences in all serum markers between slow and fast AD cognitive decliners groups. **Conclusions:** These results support the value of serum NFL as probably an interesting marker for AD but we found that it is was not indicative of cognitive decline. The others serum biomarkers like Tau, GFAP and UCHL-1 were also not differential in different decline profiles. The need of blood biomarker to identify different cognitive decline slope therefore remains a challenge.

P125: AN ULTRA-SENSITIVE MOLECULAR IMMUNO-ASSAY FOR QUANTIFICATION OF HUMAN SNAP25 IN CEREBROSPINAL FLUID. Eugeen Vanmechelen¹, Jeroen Vanbrabant¹, Naomi De Roeck², Maria Bjerke², Sebastiaan Engelborghs^{2,3}, Ann De Vos¹ ((1) ADx NeuroSciences NV, Ghent – Belgium; (2) Reference Center for Biological Markers of Dementia (BIODEM), Institute Born-Bunge, University of Antwerp, Antwerp – Belgium; (3) Department of Neurology and Memory Clinic, Hospital Network Antwerp (ZNA) Middelheim and Hoge Beuken, Antwerp – Belgium)

Background: While SNAP25 has been known for decades to be present in human cerebrospinal fluid (CSF), only one molecular assay enabling quantification of CSF SNAP25 levels has been described so far, i.e. a research assay on the Erenna system by Singulex. As pre-synaptic protein, SNAP25 could become a valuable biomarker representing synaptic degeneration, which occurs early in the pathogenesis of Alzheimer's Disease (AD). **Objectives:** The design of a novel immunoassay for SNAP25 using the ultrasensitive Single Molecule Array (SIMOA) technology (Quanterix), implementing a new combination of monoclonal antibodies (mAbs). **Methods:** We generated a new series of mAbs, targeting the N-terminus of human SNAP25. mAbs were assessed for their use in a SIMOA-format, in combination with commercially available mAbs. The novel prototype assay was subsequently assessed to generate proof-of-concept using CSF collected from patients suffering from Mild Cognitive Impairment (MCI) due to AD (n=20), as well as healthy controls (n=20). **Results:** The assay was based on one of the newly developed SNAP25 antibodies, clone SP6B3 (isotype IgG2b; affinity KD = 6nM,

based on biolayer interferometry analyses on recombinant SNAP25), which recognizes an internal epitope, i.e. L26 to L33. A sandwich format, using a synthetic peptide as candidate calibrator (ranging from 300 to 0.1pg/mL), was completed with a commercial mAb recognizing specifically the acetylated N-terminal end of SNAP25. Analytical performance: When analyzing CSF, the novel assay format was able to quantify SNAP25 in all MCI-AD samples, while levels in 6 out of the 20 samples of the control group were below the current limit of detection. All samples were measured in duplicate, resulting in an average intra-assay coefficient of variation (CV) of 4%. Clinical performance: The study demonstrated a highly significant increase (P<0.0001) in SNAP25 levels in MCI-AD versus the control group, which encompassed subjects with a normal CSF tau and CSF A β (1-42) profile. Identical results and good correlations (r=0.987; P<0.0001) were obtained using another assay format, including the same mAb specific for the acetylated N-terminus but complemented with another mAb directing SNAP25 more downstream (L26 to E37). The MCI-AD group demonstrated again significantly increased SNAP25 levels (P<0.0001). **Conclusions:** The present data confirm results for SNAP25 in CSF by mass spectrometry analyses. The proof-of-concept strengthens the further development and validation of the immuno-assay. Accompanied with other pre- and post-synaptic biomarker assays (eg, α -synuclein, neurogranin), the new assay may help the field to explore whether synaptic markers reflect synaptic degeneration and whether normalized levels of these synaptic markers may serve as an early surrogate marker in specific stages of the disease for disease-modifying therapies in AD, and/or other synaptopathies.

P126: PLASMA AND CSF BIOMARKERS FOR THE DIAGNOSIS OF ALZHEIMER'S DISEASE IN ADULTS WITH DOWN SYNDROME. A CROSS-SECTIONAL STUDY. Maria Carmona-Iragui^{1,2,3}, Bessy Benejam², Susana Fernández², Laura Videla^{1,2,3}, Isabel Barroeta^{1,3}, Daniel Alcolea^{1,3}, Jordi Pegueroles^{1,3}, Laia Muñoz^{1,3}, Olivia Belbin^{1,3}, Jordi Clarimón^{1,3}, Mony John de Leon⁴, Sebastián Videla^{2,5}, Aleksandra Maleska Maceski⁶, Christophe Hirtz⁶, Constance Delaby⁶, Sylvain Lehmann⁶, Rafael Blesa^{1,3}, Alberto Lleó^{1,3}, Juan Fortea^{1,2,3} ((1) Memory Unit, Department of Neurology, Hospital de la Santa Creu i Sant Pau- Biomedical Research Institute Sant Pau-Universitat Autònoma de Barcelona, Spain; (2) Barcelona Down Medical Center. Fundació Catalana de Síndrome de Down, Barcelona, Spain; (3) Centro de Investigación Biomédica en Red de Enfermedades Neurodegenerativas (CIBERNED), Spain; (4) New York University School of Medicine, NYU Center for Brain Health, Department of Psychiatry, New York, USA; (5) Clinical Research Support Unit, Bellvitge University Hospital / Bellvitge Biomedical Research Institute (IDIBELL) / University of Barcelona, Barcelona, Spain; (6) Université de Montpellier, CHU de Montpellier, INSERM U1183. Montpellier, France)

Background: Down syndrome (DS) is a genetically determined form of Alzheimer's disease (AD) where dementia prevalence rises exponentially with age ultimately affecting more than 90% after age 60. Diagnosis of AD in this population is challenging because of the between-subject variability of the cognitive deficits related to their intellectual disability and the lack of validated diagnostic biomarkers, which hinders the patient selection for clinical trials. **Objectives:** In search of a biomarker that could facilitate an earlier and more accurate AD diagnosis in DS, the primary objective of our study was to

assess the diagnostic performance of A β 1-40, A β 1-42, total tau (t-tau), and neurofilament light protein (NfL) levels in plasma and A β 1-40, A β 1-42, t-tau, 181-phosphorylated tau (p-tau), and NfL levels in cerebrospinal fluid (CSF) to diagnose AD in a large cohort of adults with DS. **Methods:** We performed a cross-sectional study of adults with DS and non-trisomic controls recruited between February 2013 and November 2017. Participants underwent neurologic and neuropsychological examination, blood sampling. A subset also underwent a lumbar puncture. Adults with DS were classified into asymptomatic (aDS), prodromal AD (pDS), or AD dementia (dDS) groups, blind to biomarker data. A β 1-40, A β 1-42, t-tau, p-tau -only in CSF- and NfL levels were measured in plasma and CSF with SIMOA and ELISA assays, respectively. We compared the biomarker levels between all the clinical groups and we assessed the diagnostic performance of each biomarker with ROC analyses between aDS and pDS and between aDS and dDS. **Results:** Plasma was available for 349 subjects (194 aDS, 39 pAD, 49 dDS, and 67 controls) and CSF for 162 subjects (54 aDS, 18 pAD, 22 dDS, and 67 controls). Demographics, cognitive scores, and biomarker levels are shown on the Table. There were no differences in demographics, cognitive scores, or plasma levels between the subgroup of participants with CSF available and the overall sample. Both, pDS, and dDS groups had lower scores on cognitive measures and were older than aDS subjects. Plasma A β 1-40 and A β 1-42 levels were significantly higher across all DS groups than in controls ($p < 0.001$). Plasma t-tau levels were significantly higher in the dDS group than both in controls and in aDS individuals ($p < 0.001$) and there was a trend for higher t-tau levels in dDS than in the pDS group ($p = 0.06$). Plasma NfL levels were significantly higher in all DS groups compared with controls ($p < 0.001$ for all comparisons). Regarding CSF biomarkers, there were no differences between the DS subgroups or between any of the DS groups and controls in CSF A β 1-40 levels. CSF A β 1-42 levels were lower in both pDS and dDS groups than in controls ($p < 0.001$), and there was weak evidence for lower levels in the aDS group than in controls ($p = 0.08$). The pDS and dDS groups had lower CSF A β 1-42 levels than aDS individuals ($p < 0.001$), but there were no differences between pDS and dDS groups. CSF t-tau, p-tau, and NfL levels were higher in pDS and dDS than in controls and aDS ($p < 0.001$), but their levels did not differ between pDS and dDS or between aDS and controls. The diagnostic performance of plasma biomarkers was poor ($AUC = 0.52-0.75$) except for plasma NfL levels, which had an AUC of 0.88 and 0.95 for the aDS vs pDS and aDS vs dDS comparisons (figure 1A), respectively. Meanwhile in CSF, except A β 1-40, all biomarkers had a good diagnostic performance in the aDS vs pDS comparison: 0.92, 0.81, 0.80, and 0.88 (A β 1-42, t-tau, p-tau, and NfL, respectively) and optimal performance in the aDS vs dDS comparison ($AUC > 0.90$) (figure 1B). The optimal sensitivity and specificity in differentiating aDS from dDS was 100% and 76%, respectively, using A β 1-42, with a threshold of 508.8pg/ml; 86% and 92%, respectively, using t-tau, with a threshold of 472.5pg/ml; and 100% and 87%, respectively, using CSF NfL, with a threshold of 624.6pg/ml. The DeLong's test to compare the AUC of ROC curves demonstrated no differences between plasma NfL and CSF biomarker levels ($p = 0.46$ vs CSF A β 1-42; $p = 0.66$ vs CSF t-tau, and $p = 0.18$ vs CSF NfL). However, there were differences between all these biomarkers and plasma A β 1-40, A β 1-42, and t-tau levels ($p < 0.001$). NfL levels showed a strong plasma-CSF correlation ($\rho = 0.80$, $p < 0.0001$). **Conclusion:** Plasma NfL and CSF biomarkers have optimal

diagnostic performance to detect AD in adults with DS. Our findings support the utility of plasma NfL for the early detection of AD in DS in clinical practice and as a surrogate marker of neurodegeneration in clinical trials.

Table 1
Demographics, cognitive scores, and biomarker levels of the participants

	Controls	aDS	pDS	dDS
Overall sample				
n	67	194	39	49
Sex = Male (%)	20 (29.9)	105 (54.1)	21 (53.8)	28 (57.1)
Age (mean (sd))	49.2 (7.9)	36.9 (9.6)	50.3 (4.1)	54.4 (6)
Plasma NfL, pg/mL (median [IQR])	4.15 [3.29, 5.41]	5.88 [4.42, 9.78]	15.39 [11.80, 19.13]	23.04 [17.30, 33.65]
Plasma t-tau, pg/mL (median [IQR])	2.23 [1.69, 3.89]	2.52 [1.98, 3.12]	2.71 [2.01, 4.05]	3.80 [2.76, 4.63]
Plasma A β 1-42, pg/mL (median [IQR])	9.38 [8.67, 10.43]	14.14 [12.24, 16.37]	13.77 [11.72, 15.44]	14.43 [12.66, 16.35]
Plasma A β 1-40, pg/mL (median [IQR])	198.9 [173.3, 215.1]	348.2 [304.1, 380.2]	354.3 [316.1, 374.6]	374.8 [340.8, 406]
MMSE (mean (sd))	29.4 (0.9)	NA	NA	NA
Total CAMCOG score (mean (sd))*	NA	71.7 (16.6)	56 (20.2)	45.8 (21.2)
Intellectual disability (%)				
Severe	NA	35 (18)	17 (43.6)	17 (34.7)
Mild	NA	38 (19.6)	4 (10.3)	2 (4.1)
Moderate	NA	109 (56.2)	17 (43.6)	26 (53.1)
Profound	NA	12 (6.2)	1 (2.6)	4 (8.2)
Subgroup of participants with available cerebrospinal fluid				
n	67	54	18	22
Sex = Male (%)	20 (29.9)	30 (55.6)	11 (61.1)	13 (59.1)
Age (mean (sd))	49.2 (7.9)	37.2 (9)	51.2 (3.7)	53.2 (5.9)
CSF A β 1-40, pg/mL (median [IQR])	5590 [4265, 6794]	5559 [4851.5, 7479.2]	5239 [4679.2, 6637.3]	5310.5 [4616.8, 5794.5]
CSF A β 1-42, pg/mL (median [IQR])	825.2 [702.9, 972.1]	753.7 [533, 925.1]	418 [329.0, 443.5]	391.3 [334.4, 445.5]
CSF NfL, pg/mL (median [IQR])	351.1 [297.5, 404.4]	349.1 [208.8, 454.1]	742.4 [525.6, 1403.8]	1100.2 [891.1, 1491.9]
CSF t-tau, pg/mL (median [IQR])	173.8 [133.1, 217]	177.3 [105.3, 264.5]	538.9 [251.1, 991.5]	852.8 [510.6, 1017.1]
CSF p-tau, pg/mL (median [IQR])	37 [28.3, 42]	35.9 [23.3, 59.3]	81.3 [49.3, 122.1]	95 [71, 133]
MMSE (mean (sd))	29.4 (0.9)	NA	NA	NA
Total CAMCOG score (mean (sd)**)	NA	73.4 (15.7)	61.1 (21.9)	47.7 (23.7)
Intellectual disability (%)				
Severe	NA	8 (14.8)	4 (22.2)	8 (36.4)
Mild	NA	10 (18.5)	4 (22.2)	2 (9.1)
Moderate	NA	31 (57.4)	10 (55.6)	11 (50)
Profound	NA	5 (9.3)	0 (0)	1 (4.5)

*221 of a total of 282 subjects with DS had available CAMCOG scores. **70 of a total of 94 DS subjects had available CAMCOG scores. Abbreviations: A β : β -amyloid protein; aDS: asymptomatic Down syndrome group; CAMCOG: Cambridge Cognition Examination; CSF: cerebrospinal fluid; dDS: Alzheimer disease dementia in Down syndrome group; IQR: interquartile range; MMSE: Mini mental state examination; NA: Non-applicable; NfL: neurofilament light protein; pDS: prodromal Alzheimer disease in Down syndrome group; p-tau: 181-phosphorylated tau; sd: standard deviation; t-tau: total tau.

Figure 1

ROC curves for the conversion of asymptomatic Down syndrome to Down syndrome with dementia groups using both plasma levels of biomarkers (A) and cerebrospinal fluid levels of biomarkers (B)

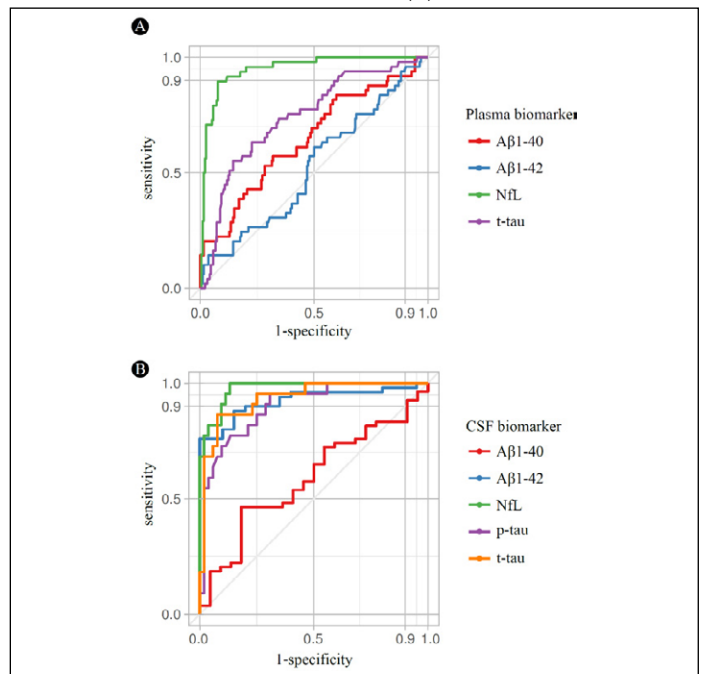

A β : β -amyloid protein; NfL: neurofilament light protein; p-tau: 181-phosphorylated tau; t-tau: total tau.

P127: THE APPLICATION OF POLYGENIC RISK SCORE ANALYSIS TO STRATIFICATION OF SUBJECTS FOR CLINICAL TRIALS IN ALZHEIMER'S DISEASE IN CARRIERS AND NON-CARRIERS OF THE APOE4 RISK ALLELE. Richard Pither PhD³; Ganna Leonenko¹; Rebecca Simms¹, Paula Daunt³, Greg Davidso³, Alex Gibson³, Olusegun Oshota³, Maryam Shoai², Kevin Banks³, Simon M Laws⁴, Zsuzsanna Nagy⁶, John Hardy², Julie Williams^{1,6}, Valentina Escott-Price^{1,6} ((1) Cardiff University, Cardiff, United Kingdom; (2) Cytox Ltd, UK, Oxford, United Kingdom; (3) UCL Institute of Neurology, London, United Kingdom; (4) Edith Cowan University, and Cooperative Research Centre (CRC) for Mental Health, Perth, Australia; (5) University of Birmingham, United Kingdom; (6) Dementia Research Institute, Cardiff, United Kingdom)

Background: The use of PET amyloid imaging and/or testing of CSF have become established techniques in the selection and stratification of subjects for clinical trials, in both the Pharma and academic sectors, but the limitations of these approaches are well understood. There is widespread agreement that more effective triage of prospective clinical trial subjects using more accessible and cost effective tests is essential, both in identifying subjects for trials and in the future and for identifying patients for treatment. The application of Polygenic Risk Score (PRS) algorithms to stratify individuals for future risk of developing Alzheimer's Disease (AD) holds tremendous promise in this regard. Cytox is working in partnership with leading academic teams in Cardiff University, The University of Birmingham and UCL to implement different PRS algorithms into our SNPfitRTM software to validate the performance of these PRS algorithms and to facilitate global access these tools by drug developers and researchers on a global basis, thereby offering a range of tailored analytical approaches to end-users. **Objectives:** To assess the potential use and application of Polygenic Risk Score (PRS) approach in the stratification of clinical trial subjects by validating the performance in well-characterised clinical sample cohorts. **Methods:** Cytox, working in partnership with Thermo Fisher Scientific, has developed specific SNP genotyping arrays from which multiple PRS algorithms can be run, specifically using variaTECTM plates developed to run on the Applied Biosystems™ GeneTitan™ Multi-Channel (MC) instrument platform from Thermo Fisher Scientific. This platform has been used to test and validate the performance of two PRS algorithms in various well-characterised clinical sample cohorts, including Alzheimer's Disease Neuroimaging Initiative (ADNI) and Australian Imaging, Biomarker & Lifestyle (AIBL), as well as other clinical study populations. The Cardiff University PRS prediction algorithm was developed using logistic regression analysis which utilises AD associated SNPs reported by the International Genomics of Alzheimer's Project (IGAP) consortium. The genoTORTM PRS algorithm has been developed using a very different pathway-driven approach, with a focus on disrupted molecular networks and their association with AD, rather than individual SNPs; the mTOR-pathway modelling approach was based on theoretical knowledge of the pathways involved. These models were tested in various independent datasets. In addition, studies were conducted to assess the concordance of results from blood and saliva in order to assess the potential of using either sample type for analysis. **Results:** The testing of the Cardiff and genoTOR PRS algorithms in well-characterised clinical sample cohorts has shown high levels of accuracy, in excess of 80%, significantly beyond that achievable using baseline assessment of ApoE (E4/

E2), age and gender. genoTOR has been shown to identify AD risk in an ApoE-independent manner and both PRS algorithms performed with high levels of predictive accuracy (AUC) in carriers and non-carriers of the ApoE4 risk allele. genoTOR-derived heat-maps can be used to further analyse the pathway-specific burdens in patients, thereby offering a more subtle stratification of trial subjects depending on the mechanisms of drug action. Importantly, this Cytox platform has been shown to perform equally well in DNA derived from either blood or saliva, thereby opening the opportunity to simple and cost-effective pre-screening of at-risk individuals. **Conclusion:** The Cardiff and genoTOR PRS algorithms offer highly valuable and complementary approaches to Alzheimer's Disease risk assessment and in doing so, allow Cytox to offer range of tailored analyses to prospective end-users. The opportunity to significantly reduce screening failure rates associated with the use of PET amyloid imaging, particularly in ApoE4 non-carriers and using saliva-derived DNA, represents a significant step forward.

P128: DO SHORT AB-PEPTIDES IMPACT THE TIME COURSE OF COGNITIVE DECLINE? AN ADNI ANALYSIS. Markus von Kienlin¹, Paul Delmar¹, Katharina Buck², Charlotta Schärfe², Simone Wahl², Karlheinz Baumann², Irene Gerlach¹, Tania Nikolcheva¹ ((1) pRED NORD, Roche Innovation Center Basel - Switzerland; (2) Biostats and Data Management, Roche Innovation Center Munich - Germany)

Background: The main constituent of amyloid plaques in Alzheimer's disease (AD) is aggregated A β 42. Current therapeutic approaches focus on clearing aggregated amyloid or reducing the secretion of A β 42 in the brain. Observations in vitro (1) and in vivo (2) suggest that shorter amyloid fragments such as A β 38 may have a beneficial impact in the amyloid cascade, reducing the aggregation propensity of A β 42 and thereby avoiding neurotoxicity. Among the therapeutic approaches targeting the production of A β 42, such a protective mechanism would constitute a key advantage for gamma-secretase modulators (GSM), as GSMs not only reduce A β 42 production but also increase the levels of shorter amyloid peptides. **Objectives:** To test whether levels of shorter amyloid peptides are correlated to disease progression. Within the ADNI (Alzheimer's Disease Neuroimaging Initiative (3)) assessments, mass spectrometry (MS) has been used to measure A β 38, A β 40 and A β 42 in CSF at baseline. We analyzed whether A β 38 levels can be associated with disease progression. **Methods:** In ADNI tables downloaded in May 2018, A β 38 CSF data are available for 400 subjects. Among these, we selected the 238 amyloid-positive subjects, based on Roche Elecsys measurements (pTau/A β 42 ratio above cut-off of 0.028, (4)). At baseline, 85 subjects have been diagnosed with AD, 123 with late mild cognitive impairment (LMCI), and 30 were cognitively normal (CN). The levels of many amyloid peptide fragments and other proteins in CSF are known to be highly correlated, possibly due to shared release or clearance mechanisms. A common way to compensate for such confounding factors is to normalize either to total CSF protein content or to some other amyloid peptide. We computed the ratio A β 38/A β 40, and used the median in each diagnostic group (CN: 0.239; LMCI: 0.231; AD: 0.230) to split the groups in "high" or "low". **Results:** The main demographic parameters of the 238 amyloid-positive subjects are shown in Table 1. Baseline characteristics are overall balanced between high and low level, except for APOE4 in

Figure 1

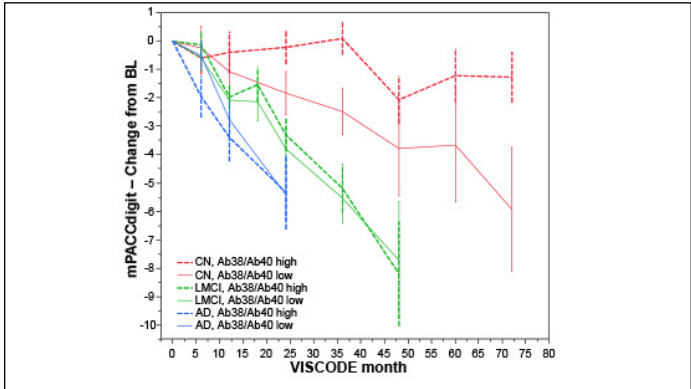

the CN group. Within each diagnostic sub-group, we then evaluated the disease progression on clinical scales, including APOE4 as a covariate. Figure 1 shows the change from baseline of the mPACCdigit (ADNI modified Preclinical Alzheimer’s Cognitive Composite with Digit Symbol Substitution) clinical score for each diagnostic sub-group (CN: red; LMCI: green; AD: blue) split by high (dashed lines) or low (solid lines) Aβ38/Aβ40 ratio. There was no difference in progression by Aβ38/Aβ40 ratio in either the LMCI or the AD groups. In the cognitively normal subjects, however, the group with the lower Aβ38/Aβ40 ratio deteriorated faster than the group with the higher ratio. **Conclusions:** In the analyzed cohort from ADNI, higher levels of Aβ38, normalized by Aβ40, are correlated with slower cognitive decline in a population which is cognitively normal but amyloid positive at baseline. This observation is not seen in the clinically more advanced groups, which may be further evidence that therapeutic interventions need to start as early as possible, prior to the onset of symptoms. The number of cognitively normal subjects in this analysis (n = 30) is very small, thus the findings need to be replicated. Furthermore, no mechanistic conclusion can be inferred from such correlation, and the potential underlying mechanisms will need further elucidation. The findings suggest that higher levels of Aβ38 contribute to slower disease progression, which might constitute an advantage for GSMs over BACE1 inhibitors for the treatment of Alzheimer’s disease. References: 1. J. Blain et al., *Alz Res & Ther* (2016); 2. B. Moore et al., *J Expt. Med.* (2018); 3. Data used in preparation of this abstract were obtained from the Alzheimer’s Disease Neuroimaging Initiative (ADNI) database (adni.loni.usc.edu). The investigators within the ADNI contributed to the design and implementation of ADNI and/or provided data but did not participate in analysis or writing of this abstract. A listing of ADNI investigators can be found at http://adni.loni.usc.edu/wp-content/uploads/how_to_apply/ADNI_Acknowledgement_List.pdf; 4. O. Hansson et al., *Alz. & Dementia* (2018)

P129: SUSTAINED ATTENTION AND MEMORY TASKS WITH CONCURRENT EEG PROVIDE POTENTIAL BIOMARKERS FOR MILD COGNITIVE IMPAIRMENT. SangYun Kim^{1,2}, Sungmin Kang³, Seong Soo A. An⁴, Young Chul Youn⁵ ((1) Department of Neurology, Seoul National University College of Medicine; (2) Clinical Neuroscience Center, Seoul National University Bundang Hospital; (3) PeopleBio Company; (4) Department of Bionano Technology, Gachon Medical Research Institute, Gachon University; (5) Department of Neurology, Chung-Ang University College of Medicine)

Background: Cumulative evidence suggested that amyloid beta oligomerization is associated with Alzheimer’s disease (AD). In prior works, we developed a new method that measured the dynamic of oligomerization of amyloid-β in plasma. We measured oligomeric form of Aβ (OAβ) in plasma by multimer detection system (MDS) after spiking synthetic Aβ and incubation over time. We could discriminate the patients with AD from age-matched normal control subjects with a sensitivity of 83.3% and a specificity of 90.0% by this technique (MDS-OAβ). Here, we report recent study results from the biomarker clinical trial of MDS-OAβ for assisting AD diagnosis, designed to investigate the clinical accuracy of the method to get approval from Korean FDA. **Methods:** The study designed to examine the Aβ oligomerization dynamics in heparin plasma. Fifty-two patients with AD and positive amyloid PET, and fifty-two elderly normal control subjects were recruited for the clinical trial, and all samples were randomized and blinded for the test. MDS-OAβ was used to determine the Aβ oligomerization levels after synthetic Aβ has been spiked into the plasma sample and incubated over time. Afterwards, we measured OAβ level by MDS ELISA. **Results:** The criteria were determined to be positive for values above 0.78 ng/ml and negative for those below. All 52 samples of AD were found to be positive, and 48 of the normal control samples were negative with positive values in 4 samples, indicating 100% sensitivity (95% CI: 100%) and 92.31% specificity (95% CI: 85.07~99.55%). Area under the curve (AUC) was 0.999. **Conclusions:** MDS-OAβ assay for detecting the increased oligomerization tendency of Aβ of plasma from patients with AD could serve as an diagnostic blood-based biomarker for AD with high sensitivity and specificity.

Table 1

Diagn.	Aβ ₃₈ /Aβ ₄₀		Gender Male/Female percent	Age [years] ± sd.	Education [years] ± sd.	APOE4 2/1/0 percent	CDR-SB mean ± sd.	MMSE mean ± sd.
	Median	Group						
CN	0.239 sd: 0.028	high	8/7 51% / 47%	76.8 ± 3.8	15.3 ± 3.3	2/5/8 13% / 33% / 53%	0 ± 0	29.3 ± 1.0
		low	10/5 67% / 33%	77.0 ± 5.5	16.2 ± 3.4	0/10/5 0% / 67% / 33%	0 ± 0	29.2 ± 0.9
LMCI	0.231 sd: 0.026	high	35/25 58% / 42%	73.5 ± 6.5	15.7 ± 2.6	9/35/16 15% / 38% / 27%	1.48 ± 0.8	27.1 ± 1.8
		low	44/19 70% / 30%	74.8 ± 8.3	15.7 ± 3.3	10/29/24 16% / 46% / 38%	1.72 ± 0.9	26.4 ± 1.7
AD	0.230 sd: 0.026	high	25/19 37% / 43%	74.3 ± 6.7	15.3 ± 2.5	12/22/10 27% / 30% / 23%	4.0 ± 1.5	23.8 ± 1.7
		low	24/17 59% / 41%	73.9 ± 9.0	15.0 ± 3.8	10/21/10 24% / 51% / 24%	4.7 ± 1.6	23.1 ± 2.0

Figure 1

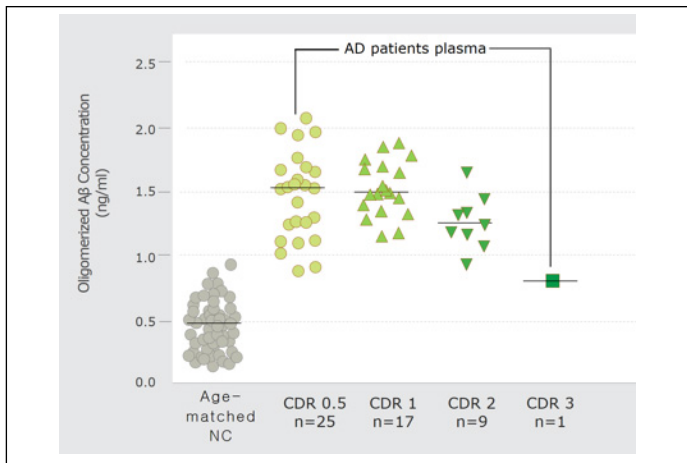

P130: TRANSCRANIAL MAGNETIC STIMULATION PREDICTS COGNITIVE DECLINE IN ALZHEIMER'S DISEASE PATIENTS. Giacomo Koch^{1,2}, Caterina Motta², Francesco Di Lorenzo², Maria Concetta Pellicciari², Sonia Bonni², Silvia Picazio², Carlo Caltagirone², Alessandro Martorana³ ((1) Department of Behavioral and Clinical Neurology; (2) Santa Lucia Foundation IRCCS, Rome, Italy; (3) Univeristy of Tor Vergata, Rome, Italy)

Objective: To determine the ability of transcranial magnetic stimulation (TMS) in detecting synaptic impairment in Alzheimer's disease (AD) patients and predicting cognitive decline since the early phases of the disease. **Methods:** We used TMS-based parameters to evaluate long-term potentiation (LTP)-like cortical plasticity and cholinergic activity as measured by short afferent inhibition (SAI) in 60 newly diagnosed AD patients and 30 healthy age-matched subjects (HS). Receiver Operating Characteristic (ROC) curves were used to assess TMS ability in discriminating AD patients from HS. Regression analyses examined the association between TMS-based parameters and cognitive decline. Multivariable regression model revealed the best parameters able to predict disease progression. **Results:** Area under ROC curve was 0.90 for LTP-like cortical plasticity, indicating an excellent accuracy of this parameter in detecting AD pathology. In contrast AUC was only 0.64 for SAI, indicating a poor diagnostic accuracy. Notably, LTP-like cortical plasticity was a significant predictor of disease progression ($p=0.02$), while no other neurophysiological, neuropsychological and demographic parameters, was associated with cognitive decline. Multivariable analysis then promoted, LTP-like cortical plasticity as the best significant predictor of cognitive decline ($p=0.01$). Finally, LTP-like cortical plasticity was found to be strongly associated with the probability of rapid cognitive decline (delta MMSE ≤ -4 points at 18 months) ($p=0.04$); AD patients with lower LTP-like cortical plasticity values showed faster disease progression. **Conclusions:** TMS-based assessment of LTP-like cortical plasticity could be a viable biomarker to assess synaptic impairment and predict subsequent cognitive decline progression in AD patients.

P131: NON-CORE BIOMARKERS (NEUROFILAMENT LIGHT, NEUROGRANIN, 14-3-3 AND YKL-40) IN THE ALZHEIMER'S DISEASE CONTINUUM, FRONTOTEMPORAL DEMENTIA AND PRION DISEASES DIAGNOSIS. Anna Antonell¹, Adrià Tort¹, José Ríos², Sergi Borrego¹, Mircea Balasa¹, Cristina Muñoz-García¹, Beatriz Bosch¹, Neus Falgàs¹, Lorena Rami¹, Kaj Blennow³, Henrik Zetterberg^{4,5}, José Luis Molinuevo¹, Albert Lladó¹, Raquel Sánchez-Valle¹ ((1) Alzheimer's disease and other cognitive disorders Unit. Hospital Clínic. IDIBAPS. Barcelona, Spain; (2) Medical Statistics Core Facility, Institut d'Investigacions Biomèdiques August Pi i Sunyer (IDIBAPS) and Hospital Clínic. Barcelona. Biostatistics Unit, Faculty of Medicine, Universitat Autònoma de Barcelona; (3) Department of Psychiatry and Neurochemistry, Institute of Neuroscience and Physiology, The Sahlgrenska Academy at the University of Gothenburg, Mölndal, Sweden; (4) Clinical Neurochemistry Laboratory, Sahlgrenska University Hospital, Mölndal, Sweden; (5) Department of Molecular Neuroscience, University College London, London, UK)

Background: Cerebrospinal fluid (CSF) β -amyloid isoform 42 (A β 42), total tau protein (t-tau) and tau protein phosphorylated at Thr-181 (p-tau) have been accepted as core biomarkers for detecting Alzheimer's disease (AD) neuropathological features in living individuals. Core AD biomarkers have demonstrated high diagnostic validity to differentiate AD from healthy subjects in clinics, but do not provide value for prognosis or disease severity staging. Neurofilament-Light chain (NF-L), a biomarker of axonal damage, Neurogranin (Ng), a postsynaptic protein, 14-3-3 protein (14-3-3), a presynaptic protein and YKL-40 protein, a biomarker of astroglial neuroinflammation have been proposed as markers of disease severity and/or are altered in other, non-AD, neurodegenerative disorders, as frontotemporal dementia (FTD) or Creutzfeldt-Jakob disease (CJD). **Objectives:** To analyze the diagnosis validity of a set of CSF biomarkers (A β 42, t-tau, p-tau, NF-L, Ng, YKL-40 and 14-3-3 proteins) in healthy controls (HC), AD, FTD and CJD patients. To investigate if these biomarkers provide disease severity staging information within the AD continuum. **Methods:** Unicentric cohort. Participants: 313 subjects: HC (n=50), asymptomatic subjects within the AD continuum (Preclinical AD) (n=21), prodromal AD (prodAD) (n=56), AD dementia (n=108), FTD (n=40) and CJD (n=38). All the participants underwent a complete clinical and neuropsychological examination. Determination of biomarkers levels was performed with commercial ELISA method for all the biomarkers except Ng, which was assessed using an in-house ELISA assay based on the monoclonal antibody Ng7. All analyses were performed by duplicate by experienced laboratory personnel blinded to clinical diagnosis. Baseline comparisons were made by means Mann-Whitney U test or Fisher's exact test and appropriated Generalized Linear Models (GLM) for adjusted comparisons by age and sex. Adjusted analyses were performed by non-parametrical approach by means rank-transformation. Accuracy for prediction of biomarkers between controls and neurodegenerative diseases were performed by ROC analyses and Likelihood Ratio Positive (LR+)= sensitivity / 1-specificity (proportion of true positives with respect to false positives) and obtained the best cut-off. All analyses were performed in SPSS (ver 25) software. **Results:** Group comparisons in neurodegenerative dementias: CSF biomarkers results were compared between groups (HC, AD, FTD and CJD). All the biomarkers showed

statistically significant differences between HC and AD. All the biomarkers were also statistically significant between HC and FTD (except for p-tau) and between HC and CJD for all the available biomarkers in CJD (NF-L, Ng, t-tau). When different clinical groups were compared, AD and FTD differed in all the biomarkers except for YKL-40, and CJD differed from both AD and FTD. The groups could be sorted according to their concentration, from lower to higher values for each non-core biomarker: NF-L: HC<AD<FTD<CJD; Ng: FTD<HC<AD<CJD; YKL-40: HC<AD & FTD and 14-3-3: HC<FTD<AD. HC showed the lowest concentration except for Ng, in which FTD showed the lowest values. Group comparisons within the AD continuum: NF-L levels differed between stages within the AD continuum. The other biomarkers, YKL-40, 14-3-3 and Ng, although they were different between HC and prodAD and HC and AD dementia, they were not different between HC and Preclinical AD and between Preclinical AD and prodAD and/or AD dementia. ROC analyses: A LR+ value >10, that indicates a good validity of the test, was obtained in the comparison HC vs neurodegenerative dementia (AD+FTD+CJD) for all the biomarkers except for YKL-40. The best cut-off for NF-L was of 1217 pg/mL (AUC 0.967, 0.96 sensitivity/0.92 specificity). Best cut-offs of 250 pg/mL (AUC 0.729, 0.477 / 0.957) for Ng and 3598 AU/mL (AUC 0.905; 0.775 / 0.933) for 14-3-3 were obtained. **Conclusions:** Biomarkers of synapse loss, axonal damage and astroglial inflammation differentiate HC from neurodegenerative dementias (AD, FTD and CJD). In the ROC analysis, NF-L showed the higher AUC value for distinguishing HC and neurodegenerative diseases in our cohort. AD and FTD differed in NF-L, Ng and 14-3-3 levels, being NF-L levels increased and Ng and 14-3-3 decreased in FTD with respect to AD. NF-L is the only biomarker that does not reach a plateau in the clinical phases of AD (prodAD and AD dementia) and differentiates severity stages within the AD continuum.

P132: AMYLOID BLOOD BIOMARKER DETECT ALZHEIMER'S DISEASE. Klaus Gerwert (*Ruhr-Universität Bochum, Bochum – Germany*)

Introduction: Diagnostic tools for detection of Alzheimer's disease (AD) are either invasive like cerebrospinal fluid (CSF) biomarkers or expensive such as positron emission tomography (PET) scanning. **Objectives:** Here, we determine the secondary structure change of amyloid-b (Ab) in human blood^{1,2}. **Discussion:** The average secondary structure distribution used as blood amyloid biomarker indicates prodromal AD and correlates with CSF AD biomarkers and amyloid PET imaging in the cross-sectional BioFINDER cohort³. In a further population-based longitudinal cohort (ESTHER), the blood biomarker detected AD several years before clinical diagnosis in baseline samples with a positive likelihood ratio of 7.9; that is, those who were diagnosed with AD over the years were 7.9 times more likely to test positive. **Conclusions:** This assay may open avenues for blood screening of early AD stages³. The sensitivity can be increase by shifting the threshold at the expense of specificity. In a two-step analysis, first the sensitivity for the blood test is increased to about 90%. Than in a second step CSF is taken from positive tested persons and the misfolding of Abeta is measured in CSF and in addition the misfolding of tau in CSF. A majority vote provides than for these sample also about 90% specificity. [1] Nabers A, Ollesch J, Schartner J, Kötting C, Genius J, Haußmann U, Klafki H, Wiltfang J, Gerwert K. An infrared sensor analysing

label-free the secondary structure of the Abeta peptide in presence of complex fluids. *J Biophotonics.*, 2016 Mar;9(3):224-234. [2] Nabers A, Ollesch J, Schartner J, Kötting C, Genius J, Hafermann H, Klafki H, Gerwert K, Wiltfang J. Amyloid- β -Secondary Structure Distribution in Cerebrospinal Fluid and Blood Measured by an Immuno-Infrared-Sensor: A Biomarker Candidate for Alzheimer's Disease. *Anal. Chem.* 2016, 88, 2755-2762 [3] Nabers A, Perna L, Lange J, Mons U, Schartner J, Güldenhaupt J, Saum KU, Janelidze S, Holleczeck B, Rujescu D, Hansson O, Gerwert K, Brenner H. Amyloid blood biomarker detects Alzheimer's disease. *EMBO Molecular Medicine* (2018), DOI 10.15252/emmm.201708763

P133: EARLY DIAGNOSIS OF MILD COGNITIVE IMPAIRMENT AND ALZHEIMER'S DISEASE BASED ON SALIVARY LACTOFERRIN. Eva Carro¹, Gorka Orive² (1) *Networked Biomedical Research Center in Neurodegenerative Diseases (CIBERNED), Spain; Group of Neurodegenerative Diseases, Hospital 12 de Octubre Research Institute (imas12), Madrid, Spain;* (2) *Laboratory of Pharmacy and Pharmaceutical Technology, Faculty of Pharmacy, University of the Basque Country, Vitoria, Spain; Networked Biomedical Research Center in Bioengineering, Biomaterials and Nanomedicine (CIBER-BBN), Spain)*

Introduction: The Alzheimer's disease (AD) process is likely initiated many years before clinical onset. Biomarkers of preclinical disease are critical for the development of disease-modifying or even preventative therapies. Current biomarkers for early disease, including cerebrospinal fluid tau and amyloid- β (A β) levels, structural and functional magnetic resonance imaging and the use of brain amyloid imaging, are limited because they are very invasive or expensive. Non-invasive biomarkers may be a more accessible alternative, but none can currently detect preclinical AD with the required sensitivity and specificity. **Methods:** Here, we show a novel, straight-forward and non-invasive approach for assessment of early stages of cognitive decline. Salivary samples from cases of amnesic mild cognitive impairment (aMCI) and AD, and neurology controls were analyzed. **Results:** We have discovered and validated a new single saliva biomarker, lactoferrin, which in our cross-sectional investigation perfectly discriminates clinically diagnosed aMCI and AD patients from a cognitively healthy control group. The accuracy for AD diagnosis shown by salivary lactoferrin was greater than that obtained from core CSF biomarkers, including total-tau and CSF A β 42. Furthermore, salivary lactoferrin can be used for population screening and for identifying those underdiagnosed subjects with very early stages of MCI and AD.

P134: EXOME-SEQUENCING IN PATIENTS WITH EARLY-ONSET ALZHEIMER'S DISEASE AND FRONTOTEMPORAL DEMENTIA: CAUSAL MUTATIONS AND GENETIC VARIANTS IN RISK GENES FOR DEMENTIA. Anna Antonell¹, Raquel Sánchez-Valle¹, Neus Falgàs¹, Mircea Balasa¹, Debayan Datta², Lluís Armengol², Sergi Borrego¹, Guadalupe Fernández¹, Beatriz Bosch¹, Jaume Olives¹, Cristina Muñoz-García¹, María León¹, Magdalena Castellví¹, Adrià Tort¹, Albert Lladó¹ ((1) *Alzheimer's disease and other cognitive disorders Unit. Hospital Clínic. IDIBAPS. Barcelona, Spain;* (2) *qGenomics (Quantitative Genomic Medicine Laboratories), Esplugues de Llobregat, Spain*)

Background: Alzheimer's disease (AD) is the most prevalent neurodegenerative disease, being of sporadic cause in most of the cases and monogenic with an autosomal dominant inheritance in a few percentage of cases (0.1-0.5%), caused by mutations in PSEN1, PSEN2 or APP genes. However, it is well known that there are several genetic risk factors elucidated in the last years through Genome-wide Association Studies (GWAS), the most important one being APOE gene allele ϵ_4 , but also TREM2, SORL1 and ABCA7. Frontotemporal dementia (FTD) is the second early-onset neurodegenerative dementia in prevalence after AD. There is a significant percentage of cases of them being monogenic, with several genes implicated at the moment (GRN, C9orf72, MAPT, VCP, CHMP2B, FUS, TARDBP, TBK1). Several variants in other genes identified in the recent years have also been described as risk factors for this disease, for example in genes SQSTM1, TREM2, and TMEM106. **Objectives:** To evaluate the ability of whole exome-sequencing (WES) to identify mutations (single nucleotide variants, small in/dels and copy number variants-CNV-) in known candidate genes and to look for new genetic variants that could be implicated in the aetiology of early-onset AD (EOAD) and FTD. To compare the probability of finding genetic missense, frameshift, splicing or stopGain variants in risk genes for these diseases in our cohort with respect to gnomAD database (general population). **Methods:** 98 individuals were selected: 57 EOAD patients with biological confirmation (positive cerebrospinal fluid AD biomarkers) and 41 FTD, without mutations in the known disease-causing genes at the moment of patients' inclusion. Whole exome was captured with MedExome (Roche) kit, and sequenced using 2x150bp paired-end reads on an Illumina NextSeq500 equipment, at an average depth above 50x. Variants were detected using standard methodologies. In a first step, we evaluated causal mutations in well-known genes that cause AD or FTD (PSEN1, PSEN2, APP, GRN, MAPT, VCP, CHMP2B, FUS, TARDBP, TBK1) or prion disease (PRNP). In the group of patients without causal mutations, we compared frequency of variants (including missense, frameshift, splicing and stopGain variants) in some risk genes for neurodegenerative dementia (TREM2, ABCA7, SORL1, SQSTM1, TMEM106B) with the global frequencies reported in the gnomAD database (123,136 exomes and 15,496 genomes from unrelated individuals sequenced as part of various disease-specific and population genetic studies). Finally we evaluated CNVs affecting causal or risk genes. **Results:** Descriptive demographics of the two groups of patients: EOAD patients (n=57; mean age of onset 52.9 ± 4.3 years; 59.6% familial history) and FTD (n=41, mean age of onset 53.8 ± 7.6 years, 48.8% familial history). Analysis of the known genes causative of dementia revealed 4 mutations likely pathogenic or pathogenic: a mutation in PSEN1 gene (p.G378R) in an AD patient and in FTD patients three mutations, a novel

mutation in MAPT gene (p.P397S), a mutation in VCP gene (p.R159H) and a new mutation in PRNP gene (p.Y163H). In the analysis of genetic variants, we detected 22 in ABCA7, 18 in SORL1, 6 in SQSTM1 and 1 in TREM2 in AD group and 10 in ABCA7, 7 in SORL1 and 1 in TREM2 in FTD group. No genetic variants in TMEM106B were detected in any patient. These frequencies were not significantly different from those observed in gnomAD database. Finally, CNV analysis revealed a partial ABCA7 deletion in a patient with FTD. This deletion also affects 4 additional contiguous genes (ARHGAP45, POLR2E, GPX4, SBNO2) and its length is approximately of 105Kb (chr19:g.1048865_1154298del). This finding was confirmed by MLPA. We have not detected any CNV affecting GRN or MAPT genes in FTD patients nor APP in AD patients. **Conclusions:** WES study allows us to detect mutations in most of the genes implicated in neurodegenerative diseases (except the C9orf72 gene hexanucleotide expansion), some of them being very rare and not evaluated in first screenings in clinical practice, as well as CNV and multiple genetic risk variants. It represents a faster and more economic approach with respect to Sanger sequencing of each gene individually when a broader approach is required. With our study we have been able to detect a disease causing mutation in 4 patients. We have not observed a different frequency of genetic risk variants in our cohort in comparison with gnomAD database.

P135: THE FUTURE OF BLOOD-BASED KINASE BIOMARKERS IN ALZHEIMER'S DISEASE. Jacques Hugon, Julien Dumurgier, Emmanuel Cognat, Claire Paquet (*Center of Cognitive Neurology, Lariboisiere Hospital, AP-HP, University of Paris Diderot, Paris, France*)

Introduction: Alzheimer's disease (AD) is characterized by memory disturbances followed by aphasia, apraxia and agnosia. Brain lesions are marked by the accumulation of the amyloid peptide in extracellular plaques, by neurofibrillary tangles composed of abnormally phosphorylated tau protein and by synaptic and neuronal loss. New findings have suggested that brain lesions could occur one or two decades before the first clinical signs. This asymptomatic preclinical phase could be a valid opportunity to put in place a secondary prevention but the detection of these brain lesions can only be achieved by cerebrospinal fluid (CSF) evaluation or molecular amyloid and tau PET imaging's. There is an urgent need to find out simple and easily accessible new biomarkers in order to organize an efficient screening in adult and aging population. Neuropathological and biochemical studies have revealed that abnormal accumulations of potentially toxic kinases are present in the brains of subjects with Mild Cognitive Impairment and AD patients. **Methods and results:** The activation of these toxic kinases could lead to abnormal tau phosphorylation, amyloid production, apoptosis and neuroinflammation. Augmented levels of these kinases have also been found in the CSF of MCI and AD patients. Over the last years the search for abnormal kinase levels has also been carried out in the blood of patients. GSK3, PKR, mTOR, DIRK1A, JNK, P70S6K, ERK2 and other kinase concentrations have been assessed and abnormal levels were found in many studies for all these kinases. For example GSK3 levels are increased in MCI and AD patients. PKR levels are also augmented in PBMC of AD patients and correlate with the cognitive decline suggesting that the evaluation of kinase levels could become blood-based biomarkers. **Conclusions:** In the future, the assessment of several blood kinase levels in large

cohorts of patients will be needed to confirm the usefulness of this test at an early phase of the disease.

P136: A PROTOTYPE SIMOA ASSAY QUANTIFYING PLASMA AMYLOID BETA 1-42 AND 1-40 ISOFORMS CAN DIFFERENTIATE AD FROM HEALTHY CONTROL SUBJECTS. Charlotte E. Teunissen¹, Elisabeth Thijssen², Inge M. W. Verberk², Hugo Marcel Vanderstichele³, Hans Heijst², Harry Twaalfhoven², Kimberley Mauroo³, Philip Scheltens⁴, Erik Stoops³ ((1) *Neurochemistry Laboratory and Biobank, Amsterdam University Medical Center, Amsterdam, Netherlands*; (2) *Neurochemistry Laboratory, Department of Clinical Chemistry, Amsterdam Neuroscience, Amsterdam University Medical Center Amsterdam, Netherlands*; (3) *ADx NeuroSciences, Gent, Belgium*; (4) *Amsterdam University Medical Center, Department of Neurology, Amsterdam, Netherlands*)

Background: The analysis of an amyloid beta (Abeta) 42 and 40 protein profile is essential for the diagnosis of Alzheimer's Disease (AD). These proteins are currently measured with expensive amyloid PET imaging technology or in CSF, obtained with the invasive procedure of a lumbar puncture. An assay sensitive enough to detect Alzheimer-specific proteins in blood would provide a minimally invasive method for pre-screening purposes and to monitor biological responses to treatments. A blood test for amyloid beta is likely to have a positive effect on clinical trial participation. It takes away the need for a lumbar puncture as inclusion criteria, while still monitoring treatment effect on a molecular level in blood. **Objectives:** The objective of this study was to develop an in-house assay with the ultra-sensitive Simoa technology for analysis of amyloid isoforms in blood and to compare its performance with a commercially available Simoa kit, and plasma and CSF ELISA. **Methods:** We developed and qualified a prototype Simoa assay using antibodies ADx101(3D6), and ADx102(21F12) or ADx103(2G3) specific for respectively Abeta 1-x, Abeta x-42 or Abeta x-40. As a proof of concept study, we analyzed EDTA-plasma samples of patients from the Amsterdam Dementia Cohort, diagnosed with AD (n=20, CSF Abeta 42 biomarker confirmed, age 69±7 years, 50% female, MMSE 21±7) and age-matched controls with subjective cognitive decline (n=20, age 63±4 years, 50% female, MMSE 27±3) using our prototype assay, the Quanterix kit, and plasma and CSF ELISA in paired samples. **Results:** The prototype plasma Abeta42/40 ratio correlates better with the CSF ELISA Abeta42/40 ratio (Spearman's Rho of R=0,633, p<0,0001) compared to the results for this ratio analyzed with Quanterix assay (R=0,527, p=0,001) or with plasma ELISA (R=0,440, p=0,010). The prototype plasma Abeta42/40 ratio correlated with MMSE (R= 0,516, p =0,001), stronger than the plasma Abeta42/40 ratio measured with the Quanterix assay (R=0,420, p=0,007) or the CSF Abeta42/40 ratio measured with ELISA (R=0,416, p=0,013). Initial ROC curve analysis shows that both plasma assays can accurately discriminate AD patients from controls (AUC prototype=0,953, 95% CI=0,891–1,000; AUC Quanterix assay=0,853, 95% CI=0,726–0,979). The Youden index for the Abeta42/40 ratio maximizes sensitivity and specificity to respectively 1.00 and 0.85 for the prototype assay and 0.80 and 0.85 for the Quanterix assay. **Conclusions:** The prototype and the commercial assay showed similar potential to discriminate between AD and controls using EDTA-plasma samples. The strong correlation of the plasma Abeta42/40 ratio with CSF Abeta42/40 ratio, and the high sensitivity of this test, shows the potential to use this assay to monitor plasma Abeta 42 and 40 levels for diagnostic pre-screening and in clinical trials.

Figure 1

Plasma Abeta 42/40 ratio measured in samples of CSF biomarker confirmed patients with Alzheimer's disease (n=20) and in age-matched controls (n=20). p-values are based on an independent samples t-test

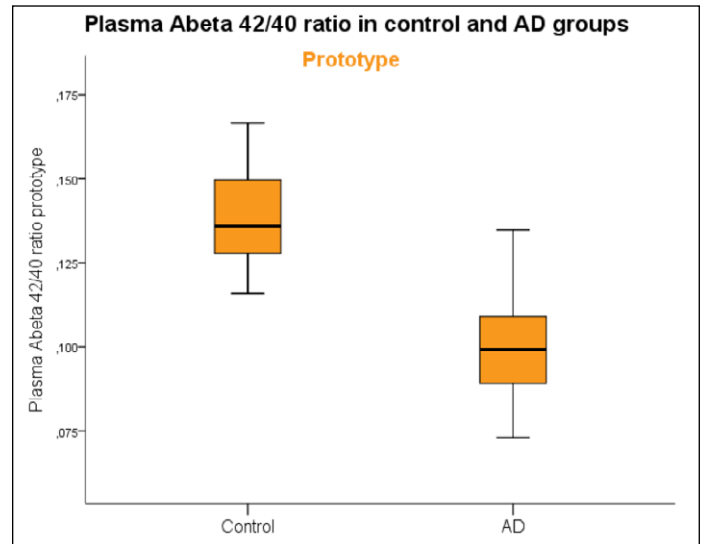

AD, Alzheimer's disease; Abeta, Amyloid beta

Figure 2

ROC curve of the Abeta 42/40 ratio, measured with three different assays. Prototype: our in-house prototype assay, Quanterix: the commercially available Quanterix assay, ELISA: ELISA assay using the same antibodies as our prototype Simoa assay

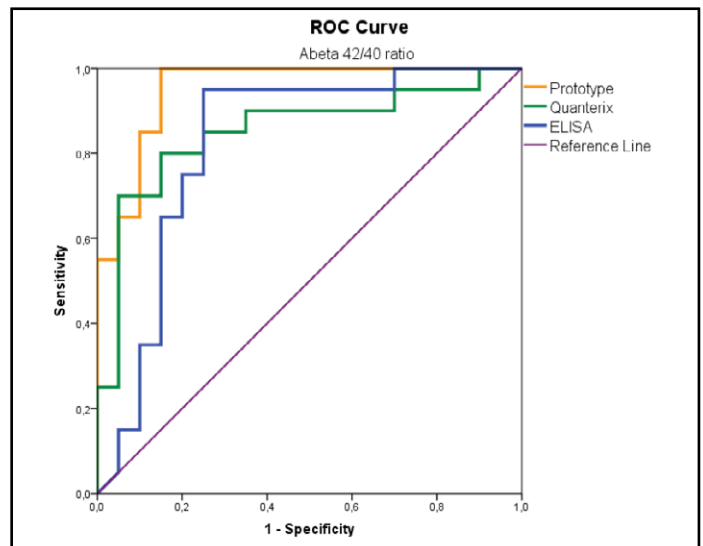

P137: SERUM-BASED PROTEINS AS NOVEL BIOMARKERS FOR THE DIAGNOSIS OF ALZHEIMER'S DISEASE. Jacques Shu Yu¹, Yue-Ping Liu² ((1) State Key Laboratory of Military Stomatology and National Clinical Research Center for Oral Disease and Shaanxi Clinical Research Center for Oral Disease, Department of Laboratory Medicine, School of Stomatology, Fourth Military Medical University, Xi'an, Shaanxi Province China; (2) Department of Laboratory Medicine, 477th Hospital of PLA, Xiangyang, Hubei Province, China)

Background: Alzheimer's disease (AD) typically affects individuals who are aged 60 or above and is quickly becoming one of the most prevalent neurodegenerative disease worldwide. Thus, a non-invasive serum-based biomarker-based diagnostic platform is eagerly awaited. The goal of this study was to identify a serum-based biomarker panel using a predictive protein-based algorithm that is able to confidently distinguish AD patients from control subjects. **Methods:** One hundred and fifty six patients with AD and the same number of gender- and age-matched control participants with standardized clinical assessments and neuroimaging measures were evaluated. Serum proteins of interest were quantified using a magnetic bead based immunofluorescent assay and a total of 33 analytes were determined. All of the subjects were then randomized into a training set and a validation set in a proportion of 70%: 30% Logistic regression and Random Forest analysis were then applied to develop a desirable algorithm for AD detection. **Findings:** Of the 33 analytes examined, 17 were found to be significantly differentially expressed between AD and control samples. The Random Forest method was found to generate a more robust predictive model than using the logistic regression analysis. Furthermore, an 8-protein-based algorithm was found to be the most robust with a sensitivity of 97.7%, specificity of 88.6%, and AUC of 99%. **Conclusion:** This study identified a total of 17 potential serum-based AD biomarkers, with 8 of these potential biomarkers ultimately selected following the construction of a novel 8-protein-based algorithm using the Random Forest method. Furthermore, the developed 8-protein biomarker panel was shown to have desirable sensitivity and specificity, thus suggesting applicability when developing an AD diagnostic. It is hoped that these results provide further insights into the applicability of serum-based screening methods and contribute to the development of lower cost, less invasive methods for diagnosing AD and monitoring progression. Key words: Alzheimer's disease, Diagnosis, serum protein-based profiles, Novel biomarkers

P138: INFLAMMATORY MARKERS TRACKING COGNITIVE AND BIOMARKER HETEROGENEITY IN MCI STAGE OF ALZHEIMER'S DISEASE. Jagan A Pillai^{1,2,3}, James Bena⁴, Lynn M Bekris⁵, James B Leverenz^{1,2,3} ((1) Lou Ruvo Center for Brain Health; (2) Neurological Institute; (3) Department of Neurology; (4) Quantitative Health Sciences; (5) Genomic Medicine Institute, Cleveland Clinic, Cleveland, OH, USA)

Background: Accumulating evidence implicates inflammatory pathways in AD pathophysiology. There is also increasing recognition of clinical phenotypic and molecular heterogeneity of AD. Currently the nature of heterogeneity within CSF biomarkers of A β 42, total Tau (T Tau) and phosphorylated tau (P Tau) corresponding to cognitive scores and inflammatory markers are still unclear. **Objectives:** We undertook to elucidate if specific inflammatory analytes could

concomitantly correlate with both levels of neurodegeneration markers and cognitive scores within the MCI stage of Alzheimer's disease. **Methods:** In a cross-sectional analysis of an ongoing study, we evaluated the association of baseline levels of CSF A β 42, T-Tau and P Tau and cognitive scores; mini mental status exam (MMSE), clinical dementia rating sum of boxes (CDR-SB) and DRS (dementia rating scale) with a multiplex panel of inflammatory analytes among MCI-AD subjects (n=48). Subjects underwent baseline cognitive testing, measurement of a multiplex panel of 86 protein analytes and concomitantly in the CSF AD biomarkers. Functional analysis by gene ontology (GO) enrichment software identified 51 inflammation related protein analytes of interest. Correlations between neurodegeneration markers (A β 42, T Tau and pTau), cognitive scores and inflammatory markers were characterized using Pearson correlations with false discovery rate of 0.05. Aggregate correlations of potential subgroups of analytes were next evaluated following combinatorial testing. The significant analytes were evaluated using a network analysis and STRING protein association network database to help understand their functional context. **Results:** Following univariate analysis, correlation between CSF T Tau levels and DRS scores trended towards significance ($\rho = -0.32$, unadjusted $p = 0.03$, FDR $p = 0.055$) but none of cognitive measures related to CSF and plasma inflammatory marker levels at baseline. CSF T Tau and P Tau correlated to CSF levels of TNFR2, VCAM1, MCP1, MMP2, β 2 Macroglobulin, α 2Macroglobulin, and VEGF ($\rho = 0.74-0.3$), $p = 0.001$). ApoCIII was positively correlated to A β 42 ($\rho = 0.45$, $p = 0.014$). In the plasma CCL4 ($\rho = 0.46$, $p = 0.025$) was positively correlated to A β 42 while insulin was negatively associated ($\rho = -0.58$, $p = 0.048$). Plasma α 2Macroglobulin correlated to T Tau and P Tau ($\rho = 0.46$, $p = 0.015$). The top Kyoto Encyclopedia of Genes and Genomes (KEGG) pathways identified that relate significant inflammatory marker levels to T tau and P Tau included TNF signaling pathway (KEGG entry: hsa04668) and cytokine-cytokine receptor interaction (human) (KEGG entry: hsa04060). **Conclusions:** Heterogeneity of inflammatory response within MCI stage of AD best tracks with neurodegeneration biomarkers rather than cognitive variables. Levels of analyte levels relating to TNF cytokine signaling pathway appears to best track severity of neurodegeneration.

P139: THE PITFALLS FOR CLINICAL TRIALS OF THE USE OF TIME POINTS EARLIER THAN 90 MIN FOR THE [18F]MK-6240 SUVR CALCULATION. Tharick A. Pascoal MD¹, Sulantha Mathotaarachchi MSc¹, Mira Chamoun², Joseph Therriault¹, Robert Hopewell², Gassan Massarweh², Andrea L. Benedet¹, Min Su Kang¹, Serge Gauthier¹, Pedro Rosa-Neto¹ ((1) Translational Neuroimaging Laboratory, McGill University Research Centre for Studies in Aging, McGill University, Montreal, Canada; (2) Montreal Neurological Institute, McGill University, Montreal, Canada)

Background: [18F]MK-6240 is a tracer with a sub-nanomolar affinity and high selectivity for neurofibrillary tangles that showed excellent physicochemical properties in early clinical observations. [18F]MK-6240 has shown pharmacokinetic characteristics compatible with a promising new generation tau tracer. As a sub-nanomolar affinity tracer, we have shown in an early observation that [18F]MK-6240 reaches the equilibrium earlier (60 min) in low as compared with medium and high binding regions, where the ratio between the total/ND binding stabilizes after 90 min. Two recent validation studies have suggested time points after 60 and 70 min for the quantification

Figure 1

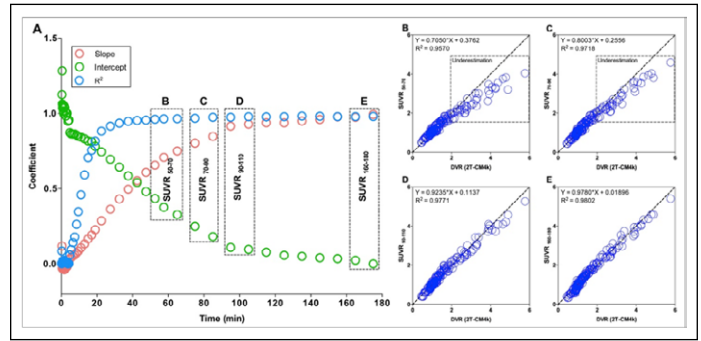

of [18F]MK-6240, based on the fact that in regions with low binding the tracer reaches stability at 60 min, and that there is a fair correlation between standardized uptake value ratio (SUVR) and compartmental model (good R2 estimates) at early time points. Importantly, these studies acknowledge that in regions with high binding SUVR stabilizes only at 90 min. Notably, the pitfalls of using inadequate early time points for the quantification of sub-nanomolar affinity tracers have already been well characterized by previous studies (1). Here, we will show the consequences of the use time points earlier than 90 min for the [18F]MK-6240 SUVR quantification for clinical trial designs. In addition, we will show how apparent good associations (high R2 values) of quantification methods may hide intrinsic quantification discrepancies. **Methods:** In vivo quantification of [18F]MK-6240 binding was performed in 16 subjects (4 AD, 3 mild cognitive impairment, 6 healthy elderly, and 3 healthy young) who underwent 180-min dynamic scans; 6 had an arterial sampling for metabolite correction. [18F]MK-6240 was quantified using full kinetic modeling with metabolite-corrected arterial input function and SUVR measure at different time points. Using the metabolite-corrected plasma input function, the kinetic parameters of [18F]MK-6240 were quantified using a reversible two-tissue compartment model with 4 parameters (2T-CM4k), assuming rapid kinetics between free and nonspecifically bound tracer. Finally, we estimated the slope, intercept, and R2 between 2T-CM4k and SUVRs measured over the 52 reconstructed time frames in order to ascertain the points with an optimal equivalence between these two methods. **Results:** Time-activity curves revealed that the radioactivity appeared rapidly in the brain with an SUV peak between 2 and 5 min after the [18F]MK-6240 injection. The time-activity curves were well described by the 2T-CM4k across individuals and brain regions (Fig. 3B). 2T-CM4k (AIC median = 11.39 (SD=33)) provided a better fit than the 2T-CM3k (AIC mean = 69.98 (SD=45)) visually and statistically across subjects and regions ($P < 0.0001$, t-test). The stabilization of total/ND binding (the ratio between target and reference region) was observed in low binding regions at 60 min and in high binding regions at 90 min, respectively. Using the cerebellar gray matter as the reference, the association between SUVR and 2T-CM4k showed progressively better goodness-of-fit and these quantification methods showed progressively more similar estimates using progressively later time frames for the SUVR calculation, essentially approaching a plateau around 90 min. The R2 of the aforementioned association was high since 30 min post-injection (>0.9). However, for time points earlier than 90 min, SUVRs showed the same values of 2T-CM4k DVR for SUVR values lower than 2, whereas for values higher than 2 SUVRs highly underestimated 2T-CM4k DVRs (Figure 1). **Conclusion:** SUVRs calculated with frames obtained earlier than 90 min leads to a progressively higher underestimation of pathology among low, medium, and high load regions. As a consequence, SUVRs estimated earlier than 90 min will underestimate the rate of tau accumulation. In the context of anti-tau clinical trials, SUVRs obtained before 90 min will reduce the drug effect size since pre-treatment estimates will present a higher underestimation than post-treatment estimates. To conclude, SUVRs using time points earlier than 90 min will generate an inaccurate estimation of drug-effect for clinical trials. (1) Olsson H, Farde L: Potentials and pitfalls using high affinity radioligands in PET and SPET determinations on regional drug induced D2 receptor occupancy—a simulation study based on experimental data. *Neuroimage* 2001, 14:936-945.

Theme: Clinical trials: Cognitive and functional endpoints

P2: OBJECTIVELY MEASURED PHYSICAL ACTIVITY AND COGNITIVE FUNCTION. Hiroyuki Umegaki¹, Taeko Makino², Kazuki Uemura³, Hiroyuki Shimada⁴, Xian Wu Cheng⁵ ((1) MD, PhD Department of Community Healthcare & Geriatrics, Nagoya University Graduate School of Medicine, Aichi, Japan; (2) PhD Institute of Innovation for Future Society, Nagoya University, Aichi, Japan; (3) Liberal Arts and Sciences, Faculty of Engineering, Toyama Prefectural University, Toyama, Japan; (4) Department of Preventive Gerontology, Center for Gerontology and Social Science, National Center for Geriatrics and Gerontology, Obu, Japan; (5) PhD, Masafumi Kuzuya, MD, PhD, Institute of Innovation for Future Society, Nagoya University, Aichi, Japan)

Background: Physical activity (PA) and cognition have reportedly been associated with each other. However, it remains to be elucidated what intensities of PA are most strongly associated with cognition. **Objective:** In the current study we aimed to determine the association between the intensities of objectively measured PA and cognitive function. **Methods:** A cross-sectional analysis of the data obtained at registration in a randomized control trial in Toyota, Japan. Participants were community-dwelling older subjects who had cognitive complaints. A battery of neuropsychological and physical assessments was performed. Daily PA data were collected with the activity monitor. PA was categorized into one of three activity levels defined as light (less than 3.0 metabolic equivalents (METs)) (LPA), moderate and vigorous (3.0MET) activity (MVPA). Partial correlation analysis was used to investigate the correlation between PA and cognition with adjustments for age, sex, and school years. We then performed a multiple regression analysis to investigate the association of cognitive performance with PA, adjusting for insulin resistance or depressive mood. **Results:** Partial correlation adjusted for age, sex, and schooling years showed that LPA was significantly correlated with the Digit Symbol Substitution test (DSS), Trail Making Test (TMT)-part A, and TMT-B, while MVPA showed no correlations. Multiple regression analysis with several models with different adjustments showed that LPA was associated with DSS, TMT-A, and TMT-B independently from insulin resistance or depressive mood. **Conclusions:** In the current study we found that LPA was significantly associated with the performance of executive functional assessments. PA enhancement may be intervention methodology and endpoint.

P3: D-CYCLOSERINE IMPROVES DIFFICULT DISCRIMINATIONS IN A PATTERN SEPARATION TASK IN ALZHEIMER'S DISEASE: IMPLICATIONS FOR DENTATE GYRUS ACTIVITY AND NEUROGENESIS.

Pascal J. D. Goetghebeur¹, Keith A. Wesnes², Steven D. Targum³
(1) Bracket LLC, Reading, UK; (2) Wesnes Cognition Ltd, Streatley on Thames, UK; (3) Bracket LLC, Boston, US)

Background: Emerging evidence suggests that decreased adult hippocampal neurogenesis may be a critical event in the early course of Alzheimer's disease (AD). Recent studies using pattern separation tasks with fMRI in animals and man have noted that difficult pattern separations (i.e. the rejection of closely similar pictures) produce increased activity in the hippocampal dentate gyrus (DG), whereas pattern completion (i.e. the identification of the original pictures) does not. Increased DG activity is associated with neurogenesis and a process that may be impaired in AD. D-Cycloserine (DCS) is a partial agonist of the glycine B co-agonist site of the N-methyl-D-aspartate receptor and has been shown to increase hippocampal neurogenesis and improve cognition in animal models. Moreover, in a scopolamine-induced forgetting paradigm in man, the addition of DCS 15 mg improved memory in young and elderly volunteers. Given the recent neurogenesis findings, we examined the effect of DCS on a specific picture pattern separation test that had been used in an unsuccessful clinical trial of subjects with AD. **Objectives:** We conducted a post-hoc analysis of specific data obtained from a large Phase III clinical trial of DCS in AD subjects conducted between 1991-1993. The clinical trial failed to show a benefit of DCS on cognitive function or any of the other clinical assessments. We sought to determine if DCS could increase accuracy on specific pattern separation stimuli that had been part of the neuropsychological assessments used in the trial. We also sought to determine if an eligibility criterion based on normative data from this task could enable a positive signal to be detected using a smaller population. **Methods:** 756 patients meeting criteria for probable Alzheimer's disease were enrolled in a randomised, double-blind, placebo controlled, multicentre phase III clinical programme of DCS given daily at 5, 15, 50 or 100 mg for 26 weeks. The mean age was 72.9 years and the mean MMSE 19.6. The Cognitive Drug Research (CDR) system, a computerized cognitive assessment battery was used as the primary efficacy measure in this study. The CDR included 5 memory tests: immediate word recognition, delayed word recognition, face recognition, picture recognition, and memory scanning. The CDR picture recognition task fulfils the requirements of a pattern separation test because it presents pictures that must later be discriminated from closely similar pictures. In our post-hoc analyses we reanalysed the data from the picture recognition task by extracting the measures of the ability to 1) correctly recognise the original pictures (pattern completion); and 2) the ability to correctly reject the closely similar pictures (pattern separation). The data was analysed separately using mixed model repeated measures. **Results:** None of the DCS doses had a statistically significant beneficial effect on the pattern completion stimuli in this patient population. On the other hand, DCS increased the accuracy on the pattern separation stimuli in a bell-shaped manner in which the DCS 15 mg dose compared with placebo significantly improved the ability of subjects to correctly reject the closely similar pictures ($p=0.003$), whereas the lower and higher doses did not. Moreover, the beneficial effect of the DCS 15 mg dose

on the pattern separation measure progressively increased over time ($p=0.003$) whereas the placebo group revealed a steady and significant decline ($p=0.0312$), the difference reaching a peak of 8.1% at week 26. Interestingly, DCS showed a similar dose-response pattern on other memory tests in the scopolamine model study with healthy volunteers. In an additional post-hoc analysis, we used 2 standard deviations from the CDR norm of age-matched healthy individuals as a subject eligibility criterion at the screen visit. In this truncated sample of 363 subjects, the signal produced by the DCS 15 mg dose was also significant compared with placebo over the study period ($p=0.0005$) and at week 26 had a greater numerical improvement over placebo of 17.7%. **Conclusions:** D-Cycloserine 15 mg improved pattern separation, a process that has been linked to neurogenesis and dentate gyrus activity, in AD patients. These data illustrate the potential value of using a pattern separation task for compounds that enhance neurogenesis. Furthermore, subject selection that includes a CDR criterion could facilitate signal detection for clinical trials. Disclosures: Dr Steve Targum and Pascal Goetghebeur are employed by Bracket Global LLC who provides the CDR test. Professor Wesnes is a consultant to Bracket Global LLC and the originator of the CDR system

P8: A MULTICENTER, OPEN-LABEL, 24-WEEK FOLLOW-UP STUDY FOR EFFICACY ON COGNITIVE FUNCTION OF DONEPEZIL IN BINSWANGER-TYPE SUBCORTICAL VASCULAR DEMENTIA.

Jay Cheol Kwon¹, Eung Gyu Kim², Jae Woo Kim³, Oh Dae Kwon⁴, Bong Goo Yoo⁵, Nam-Gon Kim⁶, Nack Cheon Choi⁷, Seon young Ahn, Byung Hwa Lee⁸, Myong Jin Kang⁹, Dae Seob Choi¹⁰, The BKVD Study Group (1) Department of Neurology, Changwon Fatima Hospital; (2) Inje University Pusan Paik Hospital; (3) Dong-A University Medical Center; (4) Daegu Catholic University Medical Center; (5) Kosin University Gospel Hospital; (6) Gimhae Jungang Hospital; (7) Gyeongsang National University Hospital; (9) Department of Radiology, Dong-A University Medical Center; (10) Gyeongsang National University Hospital)

Objectives: To evaluate the efficacy and tolerability of donepezil in patients with Binswanger type subcortical vascular dementia. **Methods:** Patients ($n=34$, mean age = 71.8 ± 7.12) with Binswanger type subcortical vascular dementia from 8 multicenter, according to clinical and neuroradiological working criteria, were selected to receive donepezil 5mg/day ($n=2$) or donepezil 10mg/day ($n=32$, after 5mg/day) for 24 weeks. Our primary endpoints were change from baseline to weeks 12 and 24 in the Dementia version of Seoul Neuropsychological Screening Battery (SNSB-D) and Korean version neuropsychiatric inventory (K-NPI). **Results:** 24 patients received donepezil completed the study (mean age = 72.0 ± 7.5 K-MMSE = 21.0 ± 5.1). After 12 weeks and 24 weeks, patients showed improvements in cognitive function on the SNSB-D compared baseline of 16.29 points at 12 weeks ($p<0.05$) and 12.44 points at 24 weeks ($p<0.05$). Significant improvements were shown in only memory domain, immediate verbal recall and delayed recall tests. Subgroup with better cognitive function (SNSB-D > 100) were more effective in frontal and memory domains than the other subgroup (SNSB-D < 100). Withdrawal rates due to adverse events were very low (4.16%). **Conclusions:** Donepezil-treated patients with Binswanger type subcortical vascular dementia demonstrated significant improvement in cognition compared with baseline, and donepezil was well tolerated. Key words: Binswanger type subcortical vascular dementia, Donepezil, cognition

P9: THE CORRELATION OF DIABETIC STATUS, ISCHEMIC AND ATROPHIC BURDENS ON BRAIN MRI AND COGNITIVE DECLINE IN SEVENTH DECADE DIABETIC PATIENTS WITH COGNITIVE IMPAIRMENT. -1 YEAR PROSPECTIVE, OBSERVATIONAL STUDY. Jay Choel Kwon, Kyungsoo Lee, Yohan Jung, Sungrae Cho, Nack-cheon Choi (Changwon Fatima Hospital, Changwon, Korea, The Republic of Samsung Changwon Hospital, Changwon, Korea, The Republic of Gyeongsang National University Hospital, Chinju, Korea)

Background: Although the increasing number of clinical researches about diabetes and cognition, many limitations and debates have been exposed and yet revealed little. Also the contribution of Alzheimer-type and/or vascular pathology to cognitive declines has been remained unclear. The aim of this study was to evaluate the contributing factors correlated with cognitive declines in selected diabetic patients with cognitive impairments prospectively. **Methods:** After interviewing 286 diabetic patients using dementia screening questionnaire in their 7th decades, we enrolled 49 subjects who have cognitive impairment (age=64.76±3.27(61-70), M:F=26:33, education=7.74±4.53 years, K-MMSE=25.37±3.92, MoCA=18.24±4.69). Korean version mini-mental status examination (K-MMSE), MoCA and several laboratory examination of diabetes and lipid were tested and repeated after 6 and 12 months. All subjects were performed Brain MRI and scored visually focusing ischemia and atrophy. **Results:** The fluctuation index of fasting blood glucose(FBS) and glycosylated hemoglobin(HbA1c) were negatively correlated with cognitive change (p=0.01, p=0.02). And low density lipoprotein(LDL) level was negatively correlated with cognitive change(p=0.02) but high density lipoprotein(HDL) was positively(p=0.03). MRI factors focusing on white matter hyperintensities and medial temporal atrophy are not significantly correlated with cognitive declines. **Conclusions:** We concluded the fluctuation rather than mean value of blood glucose level are the possible predictor of cognitive declines in diabetic patients and suggested management strategy. There is a need for larger, quantitative, clinical-neuroimaging studies to improve knowledge of the complex contributions by vascular and Alzheimer pathologies in diabetic patients.

P19: LANABECESTAT: CENTRAL MONITORING OF RATER PERFORMANCE AND ERROR CHARACTERISTICS OF EFFICACY ASSESSMENTS IN THE AMARANTH STUDY. Alette M. Wessels¹, Lisle R. Kingery², Edward I. Bartolic², Laura E. Nickell¹, Jamie A. Mullen³, John R. Sims¹ ((1) Eli Lilly and Company, Indianapolis, IN, USA; (2) Cogstate, New Haven, USA; (3) AstraZeneca Pharmaceuticals, Cambridge, MA, USA)

Background: Lanabecestat is a brain-permeable, oral inhibitor of human beta-site amyloid (A β) precursor protein-cleaving enzyme 1 (BACE1) that reduces A β production. Lanabecestat is currently under investigation as a potential disease-modifying treatment for Alzheimer's disease (AD). The primary outcome efficacy assessment of the ongoing phase 2/3 study AMARANTH is the 13-item version of the Alzheimer's Disease Assessment Scale—Cognitive subscale (ADAS-Cog13). Secondary efficacy assessments are the Alzheimer's Disease Cooperative Study—Activities of Daily Living Inventory (ADCS-ADL), the Functional Activities Questionnaire (FAQ), the Clinical Dementia Rating Scale (CDR) and the Mini-Mental

State Examination (MMSE). **Objectives:** Here we describe the central monitoring (CM) methodology and initial rater performance on the efficacy assessments in the ongoing Phase 2/3 AMARANTH study (NCT02245737). **Methods:** Raters were qualified to rate in the study based on educational background, clinical and scale administration experience. Training included voiced-over didactic presentations for all scales (with subtitles for non-English languages). For the ADAS-Cog, a video scoring exercise and an audio recorded practice administration with a mock subject was submitted for review to ensure understanding of proper procedures. CDR raters had to successfully complete and receive certification through Washington University's online CDR training program. All scales are administered by raters using paper worksheets. To promote accurate scale administration, recording, and scoring, rater performance is centrally monitored in a standardized manner by experts who reviewed scale worksheets and audio recordings. As part of the CM program, a scale review form (SRF) was created for each scale to promote detailed and consistent reviews among the reviewers. The SRF quantified and classified potential errors into the following categories: • Administration error – deviation from a standardized test administration or interviewing procedure; • Recoding error – recorded subject response on the test form for an item did not accurately reflect the subject's actual spoken response or behavior, was not captured in the manner specified during training, or a required field was left blank on the form; • Scoring error – item or summary score associated with a subject's obtained response was incorrect. The SRF was structured so that experts assessed the three error types as independently as possible. If an error in administration occurred for a particular item or subtest, there was no assumption that the resulting score for that item or subtest was incorrect as a result. The accuracy of scoring was determined by what was observable by the expert, based on the manner in which the item or subtest was actually administered by the rater. The CM sampling strategy included 1) review of scale worksheets only (i.e., Form review), or 2) review of the scale worksheets together with audio recordings of the scale administration (i.e., Audio review). Rater feedback and remediation was conducted via email or telephone. **Results:** This is an ongoing study and data available for analyses were from: 504 clinical raters (raters responsible for CDR, FAQ, and ADCS-ADL assessments), 453 ADAS-Cog raters, and 506 MMSE raters from 15 countries administering the scales in 18 languages. Across all visits, Form only reviews were completed for 4676 MMSE, 4639-ADAS Cog, 3991 CDR, 2751 ADCS-ADL and 2958 FAQ assessments. In addition, Audio reviews were completed for 1798 MMSE, 2473 ADAS-Cog, 2591 CDR, 2405 ADCS-ADL and 2205 FAQ assessments. Figure 1 summarizes the percentage of reviews with errors by review type (Form vs. Audio) across all study visits and scales for the error categories Administration, Recording and Scoring. Figure 2 shows the error prevalence for the ADAS-Cog13 subtests. **Conclusions:** • Standardized review of audio recorded scale assessments shows deviations from standard administration guidelines in 25-55% of the scale administrations. The ADAS-Cog shows higher prevalence of errors in part due to the higher number of items on the SRF and the length and complexity of the scale relative to the other scales. • Overall, scoring errors and recording errors are detected equally as often by Form review and Audio review. • These data demonstrate that Form only reviews are not sufficient for identifying all types of errors raters make when administering clinical outcome

assessments, particularly the ADAS-Cog. • Consistent with prior research, we found relatively higher rates of error on the Naming and Word Recognition subtests of the ADAS-Cog, as well as Word Recall, Delayed Word Recall, and Number Cancellation. Recording errors are most common on Naming and Orientation, and scoring errors appear most common on Constructional Praxis, Naming, Word Recognition, and Number Cancellation. • CM programs that feature audio reviews of outcome assessments allow for individualized re-training of raters with regard to proper administration of the scale. This will enhance standardized administration within and across raters and improve the overall quality of the study data.

Figure 1

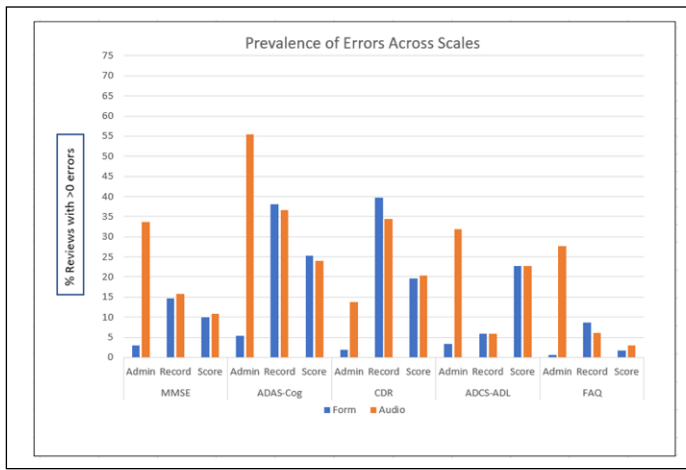

Abbreviations: Admin=administration; Record=recording; Score=scoring (errors)

Figure 2

Error prevalence for the ADAS-Cog13 subtests

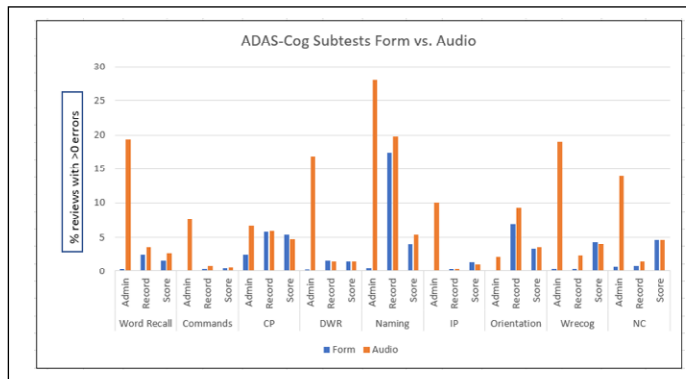

Abbreviations: Admin=administration; Record=recording; Score=scoring (errors); IS=Interview Skill; CP=constructional praxis, DWR=Delayed Word Recall, IP=Instructional Praxis, Wrecog=Word Recognition, NC=Number Cancellation

P25: EFFECTS OF SEX, EDUCATIONAL BACKGROUND, AND CKD GRADING ON COGNITIVE AND FUNCTIONAL DECLINE IN JAPANESE ADNI STUDY.

Atsushi Iwata¹, Ryoko Ihara², Kazushi Suzuki², Takeshi Iwatsubo² and the Japanese ADNI¹ ((1) *Department of Neurology, The University of Tokyo Hospital, Tokyo, Japan*; (2) *Unit for Early and Exploratory Clinical Development, The University of Tokyo Hospital Tokyo, Japan*)

Introduction: The objective of this study was to determine whether sex or education level affects the rate of cognitive decline in Japanese patients with Alzheimer’s disease Neuroimaging Initiative (ADNI) defined mild cognitive impairment (MCI). **Methods:** We accessed the entire J-ADNI dataset of 537 individuals, of whom 234 had MCI and 149 had Alzheimer’s disease (AD). We classified participants into three categories for educational history: low education, 0–9 years; moderate, 10–15 years; and high ≥ 16 years. We examined the main effects and interactions of visit, sex, and educational achievement on scores for the CDR-SOB, ADAS-cog, MMSE, and FAQ in a longitudinal manner. **Results:** Female individuals with MCI had significantly faster decline compared with male individuals during 3 years period. Moreover, highly educated individuals showed a significantly slower decline than the other groups. Sex differences in rates of decline remained after stratification by amyloid or APOE $\epsilon 4$ status, but were absent in AD for 2 years period. Further analysis revealed that subtle differences in chronic kidney disease (CKD) grade affected the rate of decline. We observed that a higher Fazekas paraventricular hyperintensity score was associated with a lower estimated glomerular filtration rate in women only. **Discussion:** In patients with MCI, sex and educational history significantly affected the rate of change in cognitive and clinical assessments. Furthermore, a subtle decline in CKD grade is associated with faster decline regardless of amyloid pathology in women.

P26: A GERMAN VERSION OF THE “FIVE WORD TEST” – DISCRIMINATING PATIENTS WITH MILD COGNITIVE IMPAIRMENT/MILD ALZHEIMER’S DISEASE, HEALTHY CONTROLS AND PATIENTS WITH DEPRESSION.

Hausner L, Dinu-Biringer R, Frölich L (*Department of Geriatric Psychiatry, Central Institute of Mental Health, Medical Faculty Mannheim, University of Heidelberg, Germany*)

Background: Diagnosing Alzheimer’s disease (AD) at early stages is essential for optimal medical treatment, so reliable but short and easy to administer tools for early detection are needed. Cognitive impairment is a core symptom of AD but is also found in other psychiatric diseases, e.g. depression. The “Five Word Test” (5WT) developed by Dubois et al. (2002) was designed to assess verbal episodic memory impairment. Impairments of this kind occur early in most cases of dementia and are supposed to represent the amnesic syndrome of hippocampal type, a core diagnostic criterion for early AD. We used a German version of the 5WT to discriminate 3 groups: (1) healthy controls (HC), (2) patients with depression (DEP) and (3) patients with mild cognitive impairment due to AD/mild AD dementia (eAD); we compared its discriminating ability with the most frequently used short assessment tool, the Mini Mental State Examination (MMSE; Folstein et al., 1975). **Methods:** All subjects were recruited through the Memory Clinic of the Central Institute of Mental Health, eAD and DEP

were out-patients living at home, HC were mainly caregivers/relatives of patients. Diagnostic categorization of MCI due to AD and mild AD dementia followed the Recommendations from the National Institute on Aging-Alzheimer's Association workgroups (Albert et al., 2011; McKhann et al., 2011) and involved AD biomarkers; depression was diagnosed clinically according to ICD-10 criteria. The CERAD-Plus test battery (Schmid et al. 2014) was used for detailed cognitive assessment. All HC subjects were cognitively unimpaired according to CERAD-Plus. Scores for further analyses were the MMSE score, the total recall score of the 5WT, a weighted total score of the 5WT according to Cowppli-Bony et al. (2005), emphasizing free recall components and finally a newly developed 5WT score emphasizing free and delayed recall components. **Results:** HC and DEP were significantly different from eAD using both the MMSE and the 5WT in all its scores while both control groups reached similar results. Receiver operating characteristic analysis for the discrimination of controls from patients with eAD revealed similar and significant discriminating abilities for each test score used. **Conclusion:** This is the first study examining the ability of the 5WT to discriminate eAD from a group of depressed patients with cognitive impairments. All test scores revealed significant abilities of the 5WT to differentiate CC from eAD comparable to the differentiation of HC from eAD and to the discrimination abilities of the MMSE. References: Albert et al. (2011), Cowppli-Bony et al., (2005), Dubois et al. (2002), Folstein et al. (1975), McKhann et al. (2011), Schmid et al. (2014)

P27: USE OF MEDICATIONS ON TRANSCRANIAL DOPPLER VASOREACTIVITY IN MILD COGNITIVE IMPAIRMENT. Shim YongSoo, Jung San (*Department of Neurology, College of Medicine, The Catholic University of Korea, Seoul, Korea; Department of Neurology, Hallym University Medical Center, Kang Nam Sacred Heart Hospital, Seoul, Korea*)

Background & Objective: Vascular risk factors and neurovascular dysfunction may also be related to Alzheimer's disease, in addition to vascular dementia. We evaluated the association between hemodynamic markers and longitudinal cognitive changes in patients with mild cognitive impairment (MCI). Furthermore, we investigated whether use of medications such as cholinesterase inhibitors and nootropics could change the vasoreactivity by using transcranial Doppler (TCD) in patients with MCI. **Methods:** A total of 71 subjects with amnesic MCI were recruited. Using transcranial Doppler (TCD) ultrasonography, cerebrovascular reactivity (CVR) was evaluated with a breath-holding test in addition to the mean flow velocity and pulsatility index of the middle cerebral artery. Each subject underwent neuropsychological testing and TCD ultrasonography annually. According to the follow-up neuropsychological studies and clinical interviews, we divided the patients with MCI into two groups, patients with stable cognitive performance and patients who progressed to AD. **Results:** Mean follow-up duration was 23.31±9.87 months. Among 71 MCI patients, 20 (28.17%) progressed from MCI to AD. After adjustment for age and baseline MMSE score, multivariate logistic regression showed that abnormal baseline PI [odds ratio 3.824, 95% CI 0.993-14.720, p=0.051], although not significant, and CVR [odds ratio 4.29, 95% CI 1.038-17.729, p=0.044] could predict of conversion from MCI to AD. In Kaplan-Meier analysis, subjects with cholinesterase inhibitors (37.85 months) showed delayed decrease in CVR, compared

to subjects without medication (27.78 months, p=0.044). **Conclusions:** We found there is a close association between hemodynamic changes represented by TCD markers and cognitive decline, supporting the clinical value of hemodynamic markers in predicting MCI patients who will progress to AD. Among TCD variables, CVR has a close relation with cognitive change, and cholinesterase inhibitors can delay the decrease of CVR in MCI. Further studies including blind trials can strengthen our results.

P53: MMSE SCREENING DATA QUALITY FOR ALZHEIMER'S DISEASE STUDIES ACROSS COUNTRIES. Jordan Mark Barbone¹, Todd M. Solomon^{1,2}, H. Todd Feaster¹, Macarena Garcia-Valdecasas Colell³, David S. Miller¹ ((1) *Bracket, Wayne, PA, USA; (2) Boston University School of Medicine, Boston, MA, USA; (3) Bracket, Reading, UK*)

Background: In part to better generalize to a global population, Alzheimer's disease (AD) clinical trials are becoming increasingly inclusive of countries around the world. Given this evolving geographic expansion, identifying regions and countries that are able to enroll appropriate subjects and provide high quality outcome data continues to be paramount. This analysis included raters from several multinational phase 2 and 3 AD clinical trials. All studies employed an enhanced electronic version of the Mini-Mental State Exam (eMMSE). We evaluated both administration and scoring errors at both Screen and Baseline visits per country. The use of Electronic Clinical Outcome Assessments (eCOA) with internal scale logic and automatic scoring algorithms has been shown to significantly reduce error rates when compared to both paper and non-enhanced eCOA versions of the scales without compromising clinical validity. The addition of audio review of scale assessments has been shown to reveal errors otherwise virtually impossible to identify through review of the scale data alone. **Objective:** To determine differences in error rates in the administration and scoring of the MMSE across countries who participated in multiple AD clinical trials. **Methods:** Data from 12,206 visits from 43 countries across four multi-national phase 2 and 3 AD clinical trials which utilized an enhanced electronic Clinical-Reported Outcome (eClinRO) version of the MMSE with Bracket's, Rater StationSM tool were evaluated. In all studies, raters were qualified and provided scoring and administration training on the eMMSE and an active study surveillance program for data quality was implemented which included monitoring at the item level data. Audio recordings of scale administration were reviewed in half of these studies. As all Screening and Baseline eMMSE data were reviewed across all studies, error rates from these visits were calculated by subtype and type (i.e., scoring and/or administration). Countries were included in the analysis if they performed a minimum of 30 assessments for each visit. **Results:** A total of 24 countries with 11,168 eMMSE assessments met the criteria for evaluation of scoring errors. Across all programs, the overall error rate in scoring was 9.00%. Of these, the country with the highest scoring error rates was Israel with 29.41% (of 34 visits) and the country with the lowest was Turkey with 1.08% (of 93 visits). As not all studies utilized audio assessment, a total of 15 countries and 5,228 eMMSE assessments were reviewed for administration deviations. Across all programs, the overall error rate of 8.82%. Of these, the highest administration deviation rate was 16.17% (of 167 visits) found in Poland and the lowest was 1.27% (of 79 visits) found in Serbia. **Conclusions:**

Prior research has demonstrated the benefits of utilizing enhanced electronic outcome measures combined with an in-study surveillance program to decrease rater error over the course of AD clinical trials. The current analysis indicates there can be substantial differences in eMMSE scale performance across countries. This variability, if not addressed, has the potential to impact data quality and lead to inappropriate enrollment of subjects in a clinical trial. Our analysis sample was limited in some regards to unbalanced number of sites, raters, and enrolled subjects per country. Error rates may be driven by early visits – or a handful of raters – but errors were remediated and reduced as the studies progressed. Thus while we do not immediately endorse changes in site selection simply based on these country findings we will continue to explore other methods in which to derive meaningful metrics for site selection. Continuing to identify raters and sites that provide high data quality remains critical to the success of AD clinical trials.

P67: THE PRESENCE OF IDENTICAL SCORING ON THE MMSE AND ADCS-ADL IN ALZHEIMER’S DISEASE CLINICAL TRIALS USING ENHANCED ECOA DEVICES. Todd M. Solomon², Jordan Mark Barbone¹, Sarah M. Karas¹, Danielle T. DiGregorio¹, Michael R. Maddock¹, David M. Miller¹, H. Todd Feaster¹ ((1) *Bracket, Wayne, PA, USA*; (2) *Boston University School of Medicine, Boston, MA USA*)

Objectives: To report on observations of identical scoring patterns in two common Alzheimer’s disease assessment scales in the clinical trial setting. **Background:** The use of Electronic Clinical Outcome Assessments (eCOA) in Alzheimer’s disease (AD) clinical trials continues to rise. By using internal scale logic and automatic scoring algorithms, the enhanced eCOA versions of common primary and secondary endpoints and screening assessments (e.g., Alzheimer’s Disease Assessment Scale cognitive subscale (ADAS-Cog), Alzheimer’s Disease Cooperative Study Activities of Daily Living Inventory (ADCS-ADL) and Mini-mental State Examination (MMSE)) have been shown to significantly reduce error rates when compared to both paper and non-enhanced eCOA versions of the scales while maintaining clinical validity^{1, 2, 3}. Further, the use of audio review of scale assessments has been shown to reveal additional errors that cannot be identified through review of the scale data alone⁴. As a potential further benefit, the use of enhanced eCOA assessments in concert with audio review can reduce the potential of erroneous data being captured which in turn helps increase reliability and validity of the overall data. In this analysis, we evaluated the frequency of identical scoring patterns longitudinally across common outcome measures in several large multinational AD trials. **Methods:** MMSE and ADCS-ADL scores were analyzed from four multi-national clinical trials in dementia which utilized enhanced Electronic Clinician-Reported Outcome (eClinRO) tool, Rater Station SM. Two of these studies included the addition of audio monitoring. Raters were trained and qualified on the proper scale administration and scoring. The first two consecutive study visits where the MMSE and ADCS-ADL were administered were compared against each other. **Results/Analysis plan:** Across four studies, a total of 3,102 visit pairs were included for the MMSE analysis and 2,410 visit pairs were included for the ADCS-ADL. Of all MMSE pairs, 496 (15.99%) had identical total scores and across studies ranged from 13.51% to 17.11%. Only 21 visit pairs (0.68%) had identical item scores; ranging from 0%

to 1.14% across studies. Of all ADCS-ADL pairs, 275 (11.41%) had identical total scores and across studies ranged from 6.11% to 14.80%. Only 52 (2.16%) had identical item scores; ranging from 0% to 5.18% across studies. Studies A and B showed lower a lower presence of identical MMSE item scoring than C and D. For the ADCS-ADL, Studies A and C showed higher rates of identical item scoring than B and D; however study B only contained a single instance of identical item scoring whilst A and C showed 9 and 42 instances, respectively. **Conclusions:** This analysis demonstrates that instances of identical total scores for individual subjects between visits are consistent across studies between with the MMSE and ADCS-ADL and the presence of identical item scoring, which has the potential to raise concerns with regard to data integrity, are quite rare. Consequently, the findings also indicated those studies which also employed additional audio monitoring had less instances of identical item level scoring overall on enhanced eCOA scales with audio capture. Thus, using enhanced eCOA with the addition of audio assessment has the potential to help increase data integrity.

Table 1
Summary of results

	Scale	Study	Visit Pairs	Identical Totals		Identical Items	
				n	%	n	%
MINDSET	MMSE	A	1391	238	17.11	7	0.50
HEADWAY	MMSE	B	290	41	14.14	0	0
CREAD 1	MMSE	C	792	132	16.67	9	1.14
CREAD 2	MMSE	D	629	85	13.51	5	0.79
MINDSET	ADCS-ADL	A	1291	131	10.15	9	0.70
HEADWAY	ADCS-ADL	B	229	14	6.11	1	0.44
CREAD 1	ADCS-ADL	C	811	120	14.80	42	5.18
CREAD 2	ADCS-ADL	D	79	10	12.66	0	0

P69: NEUROPLASTICITY-BASED VISUAL ALERTNESS TRAINING AND IMPROVEMENTS IN DECLINING EXECUTIVE FUNCTIONS IN HEALTHY OLDER ADULTS.. Thomas Van Vleet¹, Joseph DeGutis², Michelle Voss³ ((1) *Research and Development, Posit Science, San Francisco, CA, USA*; (2) *School of Medicine, Harvard University, Boston, MA, USA*; Boston VA, Boston, MA, USA; (3) *Psychology Department, University of Iowa, Iowa City, IA, USA*)

Introduction: The ability to sustain attention gradually declines with age, exacerbating normal decays in performance across multiple cognitive domains. In addition, poorly sustained attention may impair efficient learning of new information and skills. Previous studies have shown that it is possible to enhance sustained attention in patients with severe impairments following acquired brain injury, and that this generalizes to improvements in spatial attention and more global cognitive functions. Likewise, preliminary evidence has shown that enhancing sustained goal-directed attention

in healthy older adults via an approach that exploits known principles of neuroplasticity (tonic and phasic attention training - TAPAT) can transfer to improvements in executive functioning and visuospatial skill learning. In addition, early neuroimaging work has shown that TAPAT training may result in the up regulation of acetylcholine as measured by the PET acetylcholine ligand [18F]fluroethoxybenzovesamicol ([18F] FEOBV), a molecular agent previously employed to investigate brain diseases associated with presynaptic cholinergic losses (e.g., Alzheimer's). **Objectives:** Here we present the results of a phase I feasibility field trial and a larger multi-site phase II efficacy trial of TAPAT in healthy older adults. The objective was to determine the utility of this approach and the efficacy of attention/alertness training to improve executive functions and learning. **Methods:** Participants completed approximately twelve hours of TAPAT training on iPads remotely, and completed neurocognitive assessments of executive function, learning and functional abilities at baseline, post-training and after a delayed no-contact period. **Results:** Preliminary results (n = 83) demonstrated significant post-training improvements in sustained attention, inhibitory control and related executive functions (e.g., set-shifting). **Conclusions:** Intervention-related up regulation of cognitive alertness suggests that participants benefitted from a simple, at-home exercise that may contribute to reduction in potential for development of age-related cognitive decline or dementia.

Figure 1

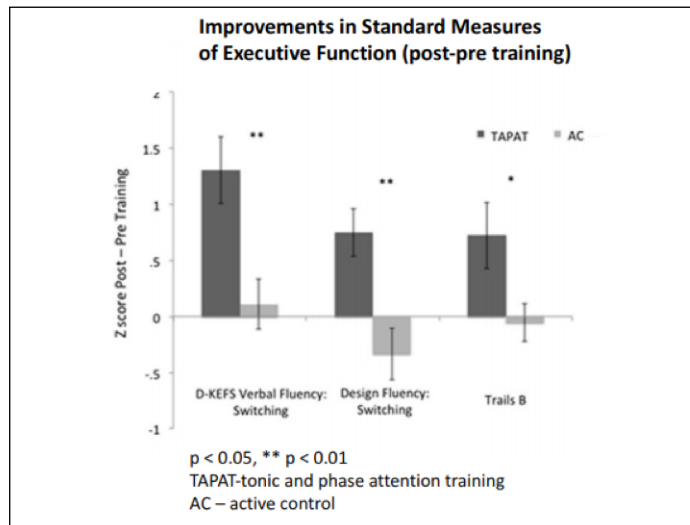

P71: THE TREATMENT RESPONSE OF GOAL ATTAINMENT SCALING IN RELATION TO GOAL NUMBER IN A CLINICAL TRIAL OF ALZHEIMER'S DISEASE PATIENTS. Kenneth Rockwood^{1,2}, Lisa McGarrigle^{1,2} ((1) Division of Geriatric Medicine, Dalhousie University, Halifax, NS, Canada; (2) DGI Clinical Inc., Halifax, NS, Canada)

Background: Goal Attainment Scaling (GAS) is an individualized outcome measure that allows patients, and/or clinicians, to set and follow personalized goals over the course of a trial. GAS guidelines recommend tracking at least three goals. Some people however, choose to set only one goal. Investigations into the psychometric properties of GAS with 3+ goals support its reliability, validity, and responsiveness. Whether responsiveness holds when GAS is calculated based on only one goal is unclear. Our objective was to compare the

responsiveness of one- and multiple-goal GAS in a randomized controlled trial of patients with Alzheimer's Disease (AD) receiving galantamine. **Methods:** Secondary analyses were conducted on data from the Video-Imaging Synthesis of Treating Alzheimer's Disease (VISTA) study, a 4-month, double-blind, placebo-controlled trial of galantamine in community-dwelling, mild to moderate AD patients (n=130). All patients/caregivers selected 3+ goals, which they ranked by importance. Two independent GAS assessments were conducted: one by patients/caregivers in a clinician-facilitated interview (patient/caregiver-rated GAS); and the other by clinicians following interviews with patients/caregivers (clinician-rated GAS). One-goal GAS was derived for patients/caregivers using their highest-ranking goal. As goals were not ranked for the clinician-rated GAS, one-goal GAS was calculated by selecting the first goal listed for each patient. Independent t-tests and standardized response means (SRM) were used to assess treatment response at 16 weeks. **Results:** At 16 weeks, multiple-goal patient/caregiver-rated GAS showed no significant difference in mean goal attainment between the galantamine and placebo groups (mean difference=1.9, p=0.27; SRM=0.20), whereas clinician-rated GAS detected significantly higher goal attainment among galantamine patients (mean difference=4.0, p=0.02; SRM=0.42). One-goal GAS, whether rated by patients/caregivers or clinicians, detected no significant differences in mean goal attainment between treatment groups, however the SRM for clinician-rated one-goal GAS was within the rubric of a small effect size (SRM=0.29). **Conclusions:** These data suggest that clinician-rated, multiple-goal GAS can detect meaningful treatment responses, but this was not observed for patient/caregiver-rated GAS, nor for one-goal GAS. The small effect size observed for clinician-rated one-goal GAS merits further investigation in a larger sample.

Table 1

Patient/caregiver and clinician GAS scores and treatment response for multiple- and one-goal GAS

Multiple-Goal GAS	Placebo		Galantamine		p	SRM	SD _p
	Mean	SD	Mean	SD			
Patient/Caregiver GAS	52.2	9.0	54.2	10.6	0.27	0.20	9.8
Clinician GAS	50.8	9.5	54.8	9.6	0.02	0.42	9.5
One-Goal GAS	Placebo		Galantamine		p	SRM	SD _p
	Mean	SD	Mean	SD			
Patient/Caregiver GAS	52.1	9.7	53.1	9.4	0.56	0.10	9.6
Clinician GAS	51.3	8.9	53.9	8.5	0.10	0.29	8.7

Note. SRMs were derived as the mean difference between treatment groups divided by the pooled standard deviation of their change. SD_p=Pooled Standard Deviation of Change

P74: PREDICTIVE VALUE AND TEST-RETEST RELIABILITY OF THE TABLET-BASED BRIEF ASSESSMENT OF COGNITION (BAC APP) FOR ASSESSMENT OF COGNITION IN AGING: PRELIMINARY FINDINGS FROM AN ONGOING NORMATIVE STUDY.

Anzalee Khan^{1,2}, Danny Ulshen¹, Alexandra Atkins¹, Danela Balentin¹, Adam Vaughan¹, Heather Dickerson¹, Brenda L. Plassman³, Kathleen A. Welsh-Bohmer³, Rich Keefe^{1,3} ((1) *NeuroCog Trials, Durham, NC, USA*; (2) *Nathan S. Kline Institute for Psychiatric Research, Orangeburg, NY, USA*; (3) *Duke University, Durham, NC, USA*)

Introduction: Continuing advances in the understanding of Alzheimer's disease (AD) progression have ignited widespread interest in the development of disease-modifying therapeutics intended for use in preclinical, largely asymptomatic populations. In order to support industry-sponsors clinical trials in this area, cognitive instruments with increased sensitivity to early cognitive decline and with appropriate normative data must be developed and validated for use in a regulated environment. The BAC App is a brief tablet-based assessment of multiple cognitive domains, including verbal memory, working memory, motor function, verbal fluency, processing speed and executive function. The BAC App minimizes site and rater burden by providing standardized presentation of task instructions and stimuli, audio-recording of subject responses, automated scoring and data storage. In the present research, we examine the criterion validity of the BAC App for the assessment of cognition in individuals with subjective cognitive decline by assessing the diagnostic sensitivity, specificity and test-retest reliability of the BAC App endpoints. **Methods:** Data currently includes 584 participants, including 245 healthy young adults (YA, <55 years), 277 healthy older adults (OA, ≥55 years), and 62 individuals with cognitive complaints. Participants with cognitive complaints were categorized as such based on total scores of ≥ 4 on the Mail-In Function Cognitive Screening Instrument (MCSFI). T scores were computed for the 6 cognitive domains of the BAC App (Verbal Memory, Digit Sequencing, Token Motor, Verbal Fluency, Symbol Coding, Tower of London) and the cognitive composite. ROC analysis and intraclass correlation (ICC, two-way random effects model for absolute agreement) coefficient were computed. Consistent with previous findings using the BACS pen-and-paper version, 1.5 SD's was identified as a position of a high probability of either significantly below or above average cognitive performance and was used as the cutoff for predictive value for the ROC analysis. **Results:** For the YA group, ICCs ranged from 0.558 (Tower of London) to 0.817 (Verbal Fluency) and 0.836 for the cognitive composite; for the OA group, ICCs ranged from 0.487 (Tower of London) to 0.818 (Verbal Fluency) and 0.881 for the cognitive composite; for the individuals with cognitive complaints, the ICCs were higher than the YA and OA groups and ranged from 0.747 (Token Motor) to 0.836 (Verbal Fluency) and 0.888 for the cognitive composite. The AUC of the BAC App when comparing YA to the individuals with cognitive complaints was good, 0.80 (95% CI: 0.70, 0.83). When a cut-off point of 1.5 SD was used, individuals without cognitive complaints were accurately identified 96.75% of the time (specificity), with a 91% chance that this identification is accurate (NPV). **Conclusions:** Preliminary findings suggest the BAC App has good discriminative validity in terms of specificity and predictive value for categorizing cognitive decline. It also has good test-retest reliability, with higher test-retest observed for individuals classified with subjective cognitive decline.

P77: CLINICAL AND AMYLOID SCREEN FAILURE RATES IN EPISODIC MEMORY MEASURES OF EARLY AD TRIALS. Selam Negash¹, Christopher Weber¹, Christopher Randolph^{1,2} ((1) *MedAvante-ProPhase*; (2) *Loyola University Medical Center*)

Background: The success rate of Alzheimer's disease (AD) trials is among the lowest for any therapeutic area (Cummings, et al., 2014). The high failure rate is part due to inappropriate inclusion of subjects into the trials that can lead to inaccurate study findings. Screening tools that can establish memory impairment and appropriate inclusion of subjects early in the recruitment process can minimize screen failure rates by identifying subjects that have a higher likelihood of meeting biomarker inclusion criteria. The present study examined two episodic memory measures – the Repeatable Battery for the Assessment of Neuropsychological Status (RBANS) and the Cogstate International Shopping List Test (ISLT) – to compare their clinical and amyloid screen failure rates in early AD trials. **Methods:** Aggregated data from five randomized, double-blind, multisite trials of early AD were analyzed. The percentages of participants that did not meet inclusion criteria (clinical screen failure rates) on each of the episodic measures were calculated. For those that met all inclusionary criteria and proceeded to PET imaging, the amyloid screen failure rates were also computed and compared between the two measures. **Results:** There were 13,260 RBANS and 4,401 ISLT assessments across the five studies. The overall clinical screen fail rates were comparable between the two memory measures, with 30% and 33% for ISLT and RBANS, respectively. On amyloid PET, there were significant differences between the two measures, with RBANS lower screen failure rate (30%) compared to ISLT (46%). **Conclusion:** These two episodic memory measures had similar screen fail rates for subjects across these five trials, but the RBANS DMI appears to be significantly more predictive of cerebral amyloid burden. One possible explanation for this finding is that the RBANS DMI is an index score composed of four separate delayed memory recall/recognition subtests, improving the reliability of the score in the measurement of anterograde memory.

P83: DETERMINANTS OF CARE REFUSAL: FROM PATIENTS SUFFERING FROM DEMENTIA TO THEIR CAREGIVERS CHARACTERISTICS. Gaëstel Y, Cerda S (*Memory Center, Bagatelle Hospital, Talence, France*)

Backgrounds: Neuropsychologists and medical staff members of memory clinics receive patients to diagnose dementia and provide advice to their caregivers. The caregivers are often family members, spouses or children. They are involved in the care and consequently frequently suffer from deteriorating health conditions. They are exposed to an increased risk of various pathologies compared to matched population that are not involved in the care of a family member. During the follow-up, we are often disappointed by critical situations that could have been prevented through professional support. Various reasons are known as potentially involved in this care refusal. Denial, a lack of consciousness of the risks or misidentification of the need for help could also be involved. **Objectives:** Our main goal was to understand which parameters influenced the decision of the patients and their caregivers when they choose to refuse or apply some recommended actions (professional support offered by a nurse for example, cognitive

stimulation). We decided to study socio-demographic and cognitive characteristics of patients suffering from dementia involved in this choice. We have also studied the caregivers' characteristics to specify our hypothesis on features influencing help refusal or acceptance. **Methods:** all consecutive patients consulting in the memory clinic were enrolled in the study. The patients did not have any previous examination in a memory clinic or diagnosis of dementia. The diagnosis was established following classical medical and neuropsychological examinations, using valid and recent cognitive tools. A specific questionnaire was then assessed, gathering data concerning existing help and suggested recommendation provided by the medical practitioner and the neuropsychologist. The patients and the caregivers were both provided advice. A letter was sent to the attending physician to ensure the understanding and continuity in the care. During the follow-up, we checked data concerning acceptance or refusal of our previous provided advices. Logistic regression analysis was conducted to study the influence of the patients and their caregivers' characteristics on decision to apply or refuse recommendations. **Results:** only few specific features were found to significantly influence refusal or acceptance of recommended actions. As an example, the status of the caregivers, i.e. being children versus spouses, increased acceptance of nurse. On the other hand, a low MMSe score resulted in an increased acceptance of participation in groups for memory stimulation. Other variables are presented and their influence discussed, as the patients' aged that seems to have no influence in the final decision to accept or refuse help. The cost of the professional intervention does not seem to be engaged in the process of decision. **Conclusion:** the psychological or emotional determinants of recommendation acceptance are difficult to understand. However, it is challenging for the professional members of memory centers, as this support might contribute to a more effective care of the patients. It might also decrease the health worsening and the negative impact on their caregivers. Through the cognitive and socio-demographical study of our study sample, we were able to specify some features influencing the choice in help or support use. We need now to conduct more detailed analysis concerning the potential effect of the advice repetition. In fact, it should be interesting to determine if some time is needed through the follow-up to influence the patients and their caregivers' decision or if only intrapersonal features are involved in such cognitive processes.

P135: THE FUTURE OF BLOOD-BASED KINASE BIOMARKERS IN ALZHEIMER'S DISEASE. Sietske A. M. Sikkes^{1,2}, Mark A. Dubbelman¹, Merike Verrijp¹, Gonzalo Sánchez Benavides³, David Facal⁵, Bruno Dubois⁴, Wiesje M. van der Flier^{1,2}, Hanna Jokinen⁶, Cristina Lojo-Seoane⁵, José Luís Molinuevo³, Arturo X. Pereiro Rozas⁵, Craig Ritchie⁷, Magdalini Tsolaki^{8,9}, Ya-Huei Wu¹⁰, Stelios Zygouris^{8,11}, Stephane Epelbaum⁴, Philip Scheltens¹ ((1) Alzheimer Center, Department of Neurology, VU University Medical Center, Amsterdam Neuroscience, Amsterdam, the Netherlands; (2) Department of Epidemiology and Biostatistics, VU University Medical Center, Amsterdam, the Netherlands; (3) BarcelonaBeta Brain Research Center, Fundació Pasqual Maragall, Barcelona, Spain; (4) Hôpital Pitié-Salpêtrière, IM2A, PARIS, France; (5) Department of Developmental Psychology, University of Santiago de Compostela, Spain; (6) Clinical Neurosciences, Neurology, University of Helsinki and Helsinki University Hospital, Finland; (7) University of Edinburgh, United Kingdom ; (8) 1st Department of Neurology, Aristotle University of Thessaloniki, Greece; (9) Greek Association of Alzheimer's Disease and Related Disorders, Greece; (10) Broca Hospital, Paris, France; (11) Network Aging Research, University of Heidelberg, Germany)

Background: The recently updated research framework for Alzheimer's disease (AD) (NIA-AA 2018) provides a clinical staging for individuals with pathophysiological changes of AD. Among the clinical symptoms are functional impairments such as difficulties with instrumental activities of daily living (IADL). The Food and Drug Administration draft guidance (2018) indicates that despite the relevance of measuring these clinically meaningful symptoms, the typical tools used to measure functional impairments are developed for patients with overt dementia, and thus potentially insensitive to changes in these early stage patients. The Amsterdam IADL Questionnaire (A-IADL-Q) was developed to capture these early stage changes, and is an adaptive, informant-based instrument, capable of measuring subtle decline in everyday functioning. The questionnaire has been translated into 13 languages according to a standardized procedure, and a short version was developed recently (Jutten et al., 2017). Because everyday activities might differ between cultures, it is important to ensure that the IADL measures and activities used in international clinical trials are comparable across cultures, but thus far, this has not yet been investigated. **Objectives:** To investigate differences in IADL functioning by examining the relevance of IADLs across cultures, item bias and the effect of potential differences on the quality of the A-IADL-Q as a cross-culturally applicable instrument for measuring functional impairments. **Methods:** We included a total of 2,201 individuals from eight cognitive aging studies (Compostela Longitudinal Study, INSIGHT pre-AD study, EPAD, Amsterdam Dementia Cohort, Broca Hospital, ALFA+ study, Helsinki Small Vessel Disease study, Greek A-IADL validation study), representing six different countries including the Netherlands, Spain, France, Greece, Finland and the United Kingdom (data forthcoming). The presence of item bias in IADL was assessed using differential item functioning (DIF) with the Amsterdam Dementia Cohort as reference sample. Items were flagged for having DIF if individuals from different countries with similar levels of functional impairment responded differently to an item. We then studied the effects of DIF on the total score by recalculating the scores while correcting for DIF and comparing these with uncorrected scores. Construct validity across different studies was examined by comparing the relationship

between the A-IADL-Q with traditional cognitive and functional measures. **Results:** Although we found differences between the countries in activity endorsement, we only found DIF for a minority of A-IADL-Q items (17/187, 9.1%). These items included activities such as using the washing machine, making appointments, and working. The effect sizes of DIF in these items were small to moderate (all pseudo $R^2 < 0.07$, see Figure 1). This indicates that these activities might be answered slightly different between groups. Despite the indication of bias on item level, the effect on the total IADL score was negligible. We found no differences in the correlations between the A-IADL-Q and conventional clinical measures, supporting the construct validity across cultures. **Conclusions:** Our findings indicate that IADL is measured in the same way, regardless of cross-cultural differences. This study supports the international use of the A-IADL-Q, due to its apparent robustness to cultural differences.

Figure 1

Mapping of DIF effect sizes for each cognitive aging study, with the Amsterdam Dementia Cohort as reference group. Items are color-coded based on effect size, with colors ranging from opaque green (no meaningful effect) to bright green (indicating a small effect, $R^2 < .035$) and red (indicating a large effect, $R^2 > .07$). Items displayed in gray could not be analyzed due to limited response categories

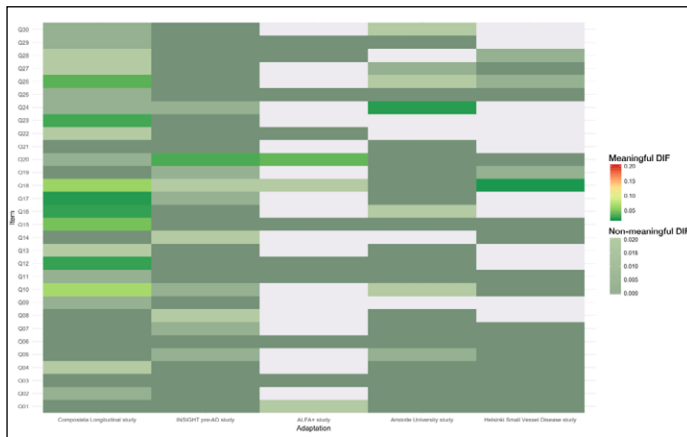

P141: CLINICAL EFFECTS OF ORAL TRAMIPROSATE IN APOE4/4 HOMOZYGOTES WITH MILD ALZHEIMER'S DISEASE (AD): RESPONDER ANALYSES OF COGNITIVE AND FUNCTIONAL OUTCOMES. Susan Abushakra¹, Bruno Vellas², Serge Gauthier³, Anton Porsteinsson⁴, Carl Sadowsky⁵, Aidan Power¹, Larry Shen⁶, Lu Wang⁶, Tim Lin⁶, John Hey¹, Martin Tolar¹ ((1) Alzheon, Inc., Framingham, MA, USA; (2) University of Toulouse, Toulouse, France; (3) McGill University, Montreal, Canada; (4) University of Rochester, Rochester, New York; (5) Palm Beach Neurology and Nova SE University, Fort Lauderdale, Florida 6Pharmapace, Inc., San Diego, CA)

Background: ALZ-801 is being developed as an oral disease modifying treatment for AD and has received Fast Track designation from the U.S. FDA. ALZ-801 is a pro-drug of tramiprosate which was designed to improve the oral bioavailability of the active agent tramiprosate. ALZ-801 provides consistent plasma levels of tramiprosate with improved GI tolerability (Hey et al. 2018). Tramiprosate which inhibits the formation of toxic soluble amyloid oligomers (Kocis et al. 2017) without binding to amyloid plaques, was

previously evaluated in Mild to Moderate AD patients. Subgroup analyses of the completed North American (NA) Phase 3 trial, showed that patients homozygous for $\epsilon 4$ allele of apolipoprotein E (APOE4/4) showed meaningful benefits in Mild AD patients (Abushakra et al. 2016 & 2017). In this subgroup of APOE4/4 homozygous patients with Mild AD, we analyzed individual responses and response rates on cognitive and functional outcomes. **Objectives:** To analyse and share the profile of individual clinical responses to tramiprosate in AD patients who are APOE4/4 homozygotes, with Mild AD, also called a responder analysis. This will inform the proportion of patients who may have a robust response, with no decline in cognition, and preservation of function over 1.5 years. **Methods:** The 78-week NA trial enrolled 1,052 AD patients with Mild to Moderate AD (MMSE16-26) to either placebo, tramiprosate 100mg BID, or 150mg BID; and included 152 APOE4/4 homozygotes across the three dose arms. At 150mg BID, APOE4/4 homozygous patients with Mild AD (two Mild AD groups: MMSE 20 or greater; MMSE 22 and greater) showed significant and/or meaningful benefits on ADAS-cog and CDR-SB (co-primary endpoints) and DAD (disability assessment). For these two APOE4/4 Mild subgroups, individual changes from baseline were plotted for patients in the placebo and high dose arms (waterfall analysis). Responders were defined by changes on ADAS-cog ≤ 0 and CDR-SB ≤ 0 (no worsening); and DAD worsening ≤ 4 points, respectively. Responder analyses were performed on the Week 78 completer dataset using summary statistics and treatments groups were compared with Fisher's exact test. The responder analyses were also performed on subjects who completed 52 weeks, 65 weeks, and 78 weeks, using repeated measure logistic regression analysis via generalized estimating equations (GEE) to account for the effect of missing data. **Results:** The APOE4/4 Mild subgroups in the high dose and placebo arms included $n=65$ (MMSE ≥ 20) and $n=50$ (MMSE ≥ 22), respectively. In MMSE ≥ 20 group, responder proportions were: ADAS-cog 57% vs. 21% ($p=0.011$), CDR-SB 35% vs. 25% (NS), and DAD 46% vs. 18% ($p=0.039$). In MMSE ≥ 22 group, the responder proportions were: ADAS-cog 67% vs. 24% ($p=0.011$), CDR-SB 44% vs. 29% (NS), and DAD 56% vs. 20% ($p=0.024$). Responder results using the repeated measure analyses showed similar results on the 3 outcomes. The safety database of tramiprosate across all APOE genotypes includes approximately 1,600 patients exposed to active drug for up to 1.5 years, and approximately 400 patients exposed for up to 2.5 years. Safety in the APOE4/4 subgroup at the high dose was also favorable, and the most common dose-dependent treatment emergent adverse events were nausea, vomiting, and weight loss (Abushakra et al. 2017). There were no events of vasogenic edema in the subset of patients who underwent MRI analyses, including the APOE4 carriers (Abushakra et al. 2016). **Conclusion:** In APOE4/4 patients, these responder analyses suggest that tramiprosate/ALZ-801 can provide significant and meaningful benefits in patients with Early/Mild AD. At the 150mg BID dose, approximately 57-67% of patients remained cognitively stable, and 46-56% had minimal or no functional decline over 1.5 years. These results will inform cut-off points for response definition, and for responder analyses in confirmatory efficacy trials with ALZ-801, which are planned in APOE4/4 homozygotes with Early/Mild AD. Considering the favorable long term safety and the promising efficacy signals in APOE4/4 homozygotes, ALZ-801 has the potential to become a meaningful treatment for this genetically-defined high risk AD population with substantial amyloid burden.

P142: EXPLORING GENETIC ASSOCIATIONS OF ALZHEIMER'S DISEASE LOCI WITH MILD COGNITIVE IMPAIRMENT NEUROCOGNITIVE ENDOPHENOTYPES. IMPACT ON COGNITIVE AND FUNCTIONAL ENDPOINTS.

Ana Espinosa¹, Begoña Hernández-Olasagarre¹, Sonia Moreno-Grau¹, Luca Kleinedam^{2,3,4}, Stefanie Heilmann^{5,6}, Isabel Hernández¹, Steffen Wolfsgruber^{2,7}, Holger Wagner⁷, Maitée Rosende-Roca¹, Ana Mauleón¹, Liliana Vargas¹, Asunción Lafuente¹, Octavio Rodríguez-Gómez¹, Carla Abdelnour¹, Silvia Gil¹, Marta Marquí¹, Miguel A. Santos-Santos¹, Ángela Sanabria¹, Gemma Ortega¹, Gemma Mont¹, Alba Pérez¹, Marta Ibarria¹, Susana Ruiz¹, Johannes Kornhuber⁸, Oliver Peters⁹, Lutz Frölich¹⁰, Michael Hüll¹¹, Jens Wiltfang¹², Martin Scherer¹³, Tobias Luck¹⁴, Steffi Riedel-Heller¹⁴, Laura Montreal¹, Pilar Cañabate¹, Mariola Moreno¹, Silvia Preckler¹, Nuria Aguilera¹, Itziar de Rojas¹, Adela Orellana¹, Montserrat Alegret¹, Sergi Valero¹, Markus M Nöthen^{2,3}, Michael Wagner^{4,5}, Frank Jessen^{4,5,7}, Wolfgang Maier^{4,5}, Lluís Tàrraga¹, Mercè Boada¹, Alfredo Ramírez^{2,3,4,5}, Agustín Ruiz¹ (1) *Research Center and Memory Clinic. Fundació ACE. Institut Català de Neurociències Aplicades, UIC-Barcelona, Spain;* (2) *German Center for Neurodegenerative Diseases (DZNE), Bonn, Germany;* (3) *Department for Neurodegenerative Diseases and Geriatric Psychiatry, University Hospital Bonn, Bonn, German;* (4) *Department of Psychiatry and Psychotherapy, University of Cologne, Cologne, Germany;* (5) *Institute of Human Genetics, University of Bonn, Bonn, Germany;* (6) *Department of Genomics, Life and Brain Center, University of Bonn, Bonn, Germany;* (7) *Department of Psychiatry and Psychotherapy, University of Bonn, Bonn, Germany;* (8) *Department of Psychiatry and Psychotherapy, University Clinic Erlangen, Erlangen, Germany;* (9) *Department of Psychiatry, Charité University Medicine, Berlin, Germany;* (10) *Department of Geriatric Psychiatry, Central Institute of Mental Health, Medical Faculty Mannheim, University of Heidelberg, Mannheim, Germany;* (11) *Center for Geriatric Medicine and Section of Gerontopsychiatry and Neuropsychology, Medical School, University of Freiburg, Freiburg, Germany;* (12) *Department of Psychiatry and Psychotherapy, University of Göttingen, Göttingen, Germany;* (13) *Department of Primary Medical Care, University Medical Center Hamburg-Eppendorf, Hamburg, Germany;* (14) *Institute of Social Medicine, Occupational Health and Public Health, University of Leipzig, Leipzig, Germany)*

Background: Alzheimer's disease (AD) is the most common cause of dementia, representing 50–60% of all cases. The risk of AD results from complex interactions of genetics, epigenetics, and environmental factors. In AD, the contribution of genetic factors to disease occurrence is estimated at up to 79%. Since the advent of high throughput genomics and genome-wide association studies (GWAS), research into the genetics of AD has been highly successful in identifying risks factors for the disease. In 2013, the International Genomics of Alzheimer's Project consortium analyzed > 74,000 individuals, identifying 21 risk loci for AD besides apolipoprotein E (APOE), 11 of which were novel susceptibility factors; however, while such studies identified factors contributing to general susceptibility to AD, associations with specific endophenotypes, such as disease progression or cognitive functions, are less clear. For example, for disease progression to AD dementia, the only consistent association identified is with APOE. Endophenotypes are quantitative trait loci (QTLs) believed to be closely related to underlying disease pathophysiology. Hence, by using quantitative endophenotypes, rather than qualitative

case/control status, as the phenotype for a genetic study, it is possible to reduce clinical diagnostic heterogeneity, thus increasing the power to detect genetic associations. In addition, this approach can provide more specific hypotheses for the biological pathways via which associated variants modulate disease progression. As a proof of principle of this strategy in AD, we and others have identified and replicated genetic factors by analyzing GWAS data together with biomarkers of AD, such as cerebrospinal fluid levels of amyloid-42, Tau, and phosphorylated Tau. Crucially, the sample sizes required for these studies are several orders of magnitude smaller than those used in case/control designs. Neuropsychological tests represent a good source of neurocognitive endophenotypes (NEs) for AD, particularly those related to episodic memory impairment. Impairment of episodic memory is usually the earliest clinical symptom in AD dementia, and in the prodromal phase of AD dementia it is referred to as mild cognitive impairment (MCI). We reported that individuals classified as probable amnesic (Pr-aMCI), that is, those with memory storage impairment (impaired recall and recognition) and an absence of comorbidities that could explain these cognitive deficits (e.g., cerebrovascular disease, anxiety, or depression), have an 8.5-fold increased risk of conversion to dementia (mainly AD), compared with those classified as having a possible non-amnesic (Pss-naMCI) condition. Although is anticipated that the genetic factors associated with AD susceptibility will influence NEs during MCI, e.g., impaired episodic memory impairment, as a reliable early manifestation of disease, the systematic investigation of the relationships between AD genetic risk factors and their endophenotypic expression remains in its infancy. **Objectives:** The aim of the present study was to investigate the relationship between well-known AD-associated single nucleotide polymorphisms (SNPs) and individual NEs routinely evaluated during diagnosis of MCI, AD, and other dementias. Using genetic association techniques and three independent MCI datasets (n = 2332 subjects), we explored associations between AD loci and neuropsychological measures obtained from subjects with MCI. **Methods:** The Fundació ACE (ACE) dataset, comprising information from 1245 patients with MCI, was analyzed, including the total sample, amnesic MCI (aMCI) (n = 811), and non-amnesic MCI (naMCI) (n = 434). As probable MCI patients with memory impairment have a higher risk of AD, which could influence the statistical power to detect genetic associations, the MCI phenotype was also stratified into four related conditions: probable (Pr)-aMCI (n = 262), Pr-naMCI (n = 76), possible (Pss)-aMCI (n = 549), and Pss-naMCI (n = 358). Replication analyses were performed using data from the German study on Aging, Cognition and Dementia in primary care patients (AgeCoDe), and the German Dementia Competence Network (DCN). SNP associations with NEs were calculated in PLINK using multivariate linear regression analysis adjusted for age, gender, and education. **Results:** In the total MCI sample, APOE-ε4 was significantly associated with the memory function NEs 'delayed recall' ($\beta = -0.76$, $p = 4.1 \times 10^{-10}$), 'learning' ($\beta = -1.35$, $p = 2.91 \times 10^{-6}$), and 'recognition memory' ($\beta = -0.58$, $p = 9.67 \times 10^{-5}$) (Figure 1); and with 'delayed recall' in the aMCI group ($\beta = -0.36$, $p = 2.96 \times 10^{-5}$). These results were confirmed by replication in the AgeCoDe and DCN datasets. APOE-ε4 was also significantly associated with the NE 'learning' in individuals classified as having Pss-aMCI ($\beta = -1.37$, $p = 5.82 \times 10^{-5}$). Moreover, there was a near study-wide significant association between the

HS3ST1 locus (rs6448799) and the ‘backward digits’ working memory NE ($\beta = 0.52$, $p = 7.57 \times 10^{-5}$) among individuals with Pr-aMCI, while the AP2A2 locus (rs10751667) was significantly associated with the language NE ‘repetition’ ($\beta = -0.19$, $p = 5.34 \times 10^{-6}$) (Figure 2). **Conclusions:** Our findings support specific associations of established AD-associated SNPs with MCI NEs. **Keywords:** Alzheimer’s disease, mild cognitive impairment, neurocognitive endophenotypes, genome-wide association studies, single nucleotide polymorphism.

Figure 1
MCI Total sample Heat Map

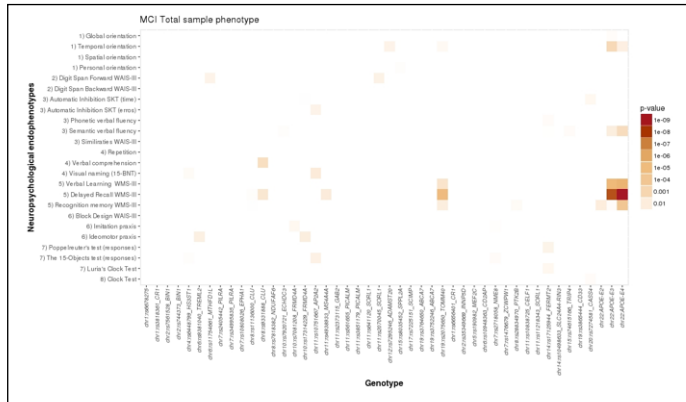

1) Orientation; 2) Attention and working memory; 3) Processing speed and Executive functions; 4) Language; 5) Verbal Learning and Memory; 6) Praxis; 7) Visual gnosis; 8) Global Cognition; Global orientation, summary of Temporal + Spatial + Personal orientations; WAIS-III: Wechsler Adult Intelligence Scale, Third edition; SKT: Syndrome Kurz Test; 15-BNT: the abbreviated Boston Naming Test with 15 items; Verbal learning WMS-III = 1st+2nd+3rd+4th trial scores; WMS-III: Wechsler Memory Scale, Third Edition.

Figure 2
Pr-aMCI subtype Heat Map

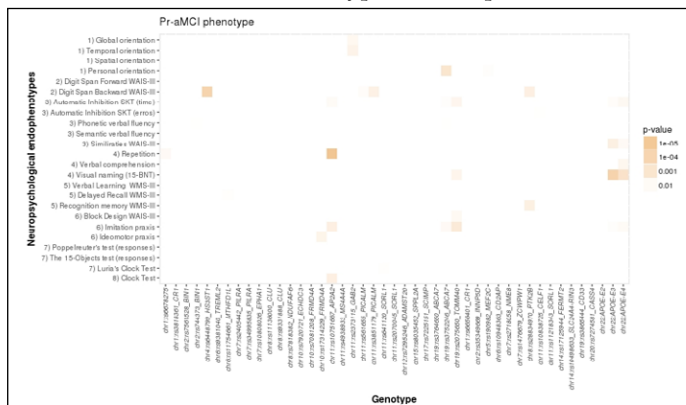

1) Orientation; 2) Attention and working memory; 3) Processing speed and Executive functions; 4) Language; 5) Verbal Learning and Memory; 6) Praxis; 7) Visual gnosis; 8) Global Cognition; Global orientation, summary of Temporal + Spatial + Personal orientations; WAIS-III: Wechsler Adult Intelligence Scale, Third edition; SKT: Syndrome Kurz Test; 15-BNT: the abbreviated Boston Naming Test with 15 items; Verbal learning WMS-III = 1st+2nd+3rd+4th trial scores; WMS-III: Wechsler Memory Scale, Third Edition.

P143: BASELINE CHARACTERIZATION OF THE EUROPEAN PREVENTION OF ALZHEIMER’S DEMENTIA (EPAD) LONGITUDINAL COHORT STUDY (LCS). Michael T. Ropacki¹, John Harrison^{2,3}, Joel Kramer³, Christopher Randolph⁴, Jeffrey Kaye⁵, Bruce Alcala⁶, Karen Ritchie^{7,8,9} ((1) Strategic Global Research & Development, Half Moon Bay, USA; (2) Metis Cognition Ltd, UK; (3) Alzheimer Center VUmc, Amsterdam, Netherlands; (4) Department of Neurology Memory and Aging Center, University of California at San Francisco – San Francisco, USA; (5) Department of Neurology, Loyola University Medical Center, Maywood, USA; (6) Neurology and Biomedical Engineering, Oregon Health and Science University, Portland, USA; (7) Institut National de la Santé et de la Recherche Médicale, U1061 Neuropsychiatrie, Montpellier, France; (8) Faculty of Medicine, University of Montpellier, Montpellier, France; (9) Center for Dementia Prevention, University of Edinburgh, Edinburgh, UK)

Background: The European Prevention of Alzheimer’s Dementia (EPAD) program aims to recruit up to 6,000 participants, from existing national and regional registers of people at-risk for developing Alzheimer’s dementia, and follow them every 6-months for the first year and then annually thereafter in a longitudinal cohort study (LCS)1, 2. From the LCS cohort, up to 1,500 participants will be enrolled in a large-scale, multiarm proof of concept (PoC) interventional trial in prodementia Alzheimer’s disease (AD). The purpose of this presentation is to provide an overview of the baseline characterization of the first 500 subjects (N= 500: EPAD V500.0), and specifically review their neurocognitive performance on the EPAD Neuropsychological Evaluation (ENE) and other clinical and cognitive outcome measures [i.e., clinical outcome assessments (COAs)] frequently employed in preclinical AD trials2,3. Sample characteristics and performance will be compared across between groups such as amyloid status and APOE. **Objectives:** 1. Characterize the first 500 subjects enrolled in EPAD and examine their performance on the ENE, as well as other clinical and cognitive outcome measures (COAs) including the Geriatric Depression Scale (GDS), State-Trait Anxiety Inventory (STAI), Pittsburgh Sleep Quality Index (PSQI), Clinical Dementia Rating (CDR) and Amsterdam Instrumental Activities of Daily Living Questionnaire. 2. Examine group differences on the ENE and the other COAs by positive/negative AD family history, amyloid, APOE, as well as tau status. 3. Explore the ENE and other COAs data for range restrictions, including floor and ceiling effects. 4. Assess the relationship (i.e., correlations) between the primary, secondary and exploratory outcome measures in the EPAD LCS. **Methods:** The EPAD LCS has been recruiting participants from existing national and regional registers of people at-risk for developing Alzheimer’s dementia, and following them every 6-months for the first year, and then annually thereafter. Longitudinal assessments include the ENE and COAs, as well as fixed (e.g., genetic) and modifiable risk factors to build robust disease and clinical models for preclinical and prodromal Alzheimer’s dementia. Presented data will focus on the baseline characterization of the first 500 enrolled subjects (EPAD V500.0 database) collected from 14 trial delivery centers across Europe. **Results:** Presented results will include analyses of the first 500 subjects enrolled in the EPAD LCS and, specifically, performance on the ENE, as well as the other COAs as detailed in the objectives. Groups defined a priori by positive/negative family history of AD, amyloid, APOE and tau status will also be compared across the ENE

and other COAs. Performance on potential covariates like the GDS and STAI will be explored, and influence on the ENE and other COAs will be presented. Finally, baseline psychometric characteristics including the ENE and COAs dynamic range of performance, as well as examination of floor and ceiling effects will be presented. **Conclusion:** Conclusions will be forthcoming following the planned analyses and review of the data. Overall, data from this presentation will be valuable to those planning, designing and running trials in early AD, especially considering the recently revised regulatory guidance (FDA: Early AD: Developing Drugs for Treatment; EMA: Guideline on the clinical investigation of medicines for the treatment of AD) and 2018 National Institute on Aging -Alzheimer's Association (NIA-AA) Research Framework. **References:** 1. Ritchie, CW, Molinuevo, JL, Truyen, L, Satlin, A, Van der Geyten, S, Lovestone, S, European Prevention of Alzheimer's Dementia (EPAD) project. Development of interventions for the secondary prevention of Alzheimer's dementia: the European Prevention of Alzheimer's Dementia (EPAD) project. *Lancet Psychiatry*, 2016 Feb; 3(2): 179-86. 2. Ritchie, K, Ropacki, M, Albala, B, Harrison, J, Kaye, J, Kramer, J, Randolph, C, Ritchie, CW. Recommended cognitive outcomes in preclinical Alzheimer's disease: Consensus statement from the European Prevention of Alzheimer's Dementia project. *AlzDem*, 2017 Dec; 13(2): 186-195. 3. Mortamais, M, Ash, JA, Harrison, J, Kaye, J, Kramer, J, Randolph, C, Pose, C, Albala, B, Ropacki, MT, Ritchie, CW, Ritchie, K. (2017). Detecting cognitive changes in preclinical Alzheimer's disease: A review of its feasibility. *Alzheimer's & Dementia*, 13(4), 468-492.

P144: TWO DISTINCT MODELLING APPROACHES OF COGNITIVE DECLINE AND TIME TO DIAGNOSIS OF MCI/DEMENTIA TO INFORM STUDY DESIGN AND TO IMPROVE RISK PREDICTION IN PRECLINICAL ALZHEIMER'S DISEASE. Angelika Caputo¹, Ana Graf¹, Cristina Lopez Lopez¹, Valery Risson¹, Giulia Lestini¹, Neva Coello¹, Amy Racine¹, Ines Paule¹, Luyuan², Helene Karcher³ ((1) Novartis Pharma AG, Basel, Switzerland; (2) Analytica Laser, a Certara company, Paris, France (3) Analytica Laser, a Certara company, London, UK)

Background: The Alzheimer's Prevention Initiative (API) Generation Program consists of two ongoing clinical trials, Generation Study 1 and 2. The trials are recruiting cognitively unimpaired participants ages 60-75 who are APOE4 carriers: homozygotes in Generation 1; homozygotes and heterozygotes with elevated brain amyloid in Generation 2. Endpoints of these trials include time-to-event (first diagnosis of mild cognitive impairment or dementia due to AD, TTE) and cognitive measures like the Alzheimer's Prevention Initiative Cognitive Composite (APCC) score. The APCC is expected to track preclinical cognitive decline in individuals who subsequently progress to the clinical stages of late-onset AD. The Insights to Model Alzheimer's Progression in real life (iMAP) study will be launched in parallel to the Generation Program to assess the ability of APCC and RBANS to predict clinically meaningful outcomes and to describe disease progression throughout the full spectrum of Alzheimer's disease (AD). **Methods:** We performed exploratory analyses of natural history data and used model-based approaches to understand the natural time course of novel endpoints in early AD. A first two-step approach was applied to fit models to TTE and APCC separately. Firstly, we developed a TTE model using parametric survival functions.

The TTE model was fitted to observational / non-intervention longitudinal data from the National Alzheimer's Coordinating Center (NACC) and from three cohort studies (ROS, MAP and MARS) of aging and dementia at the Rush Alzheimer's Disease Center. The second step consisted of mixed-effects models describing APCC scores over time that were fitted to two sub-populations in the Rush cohorts: the "progressors", i.e. subjects with first diagnosis within eight years, and "non-progressors", i.e. subjects who were either not diagnosed or only after eight years. A time scale anchored at the time of diagnosis was underlying the progressor model. These models served as basis for simulating a large pool of individual subject records to reflect a wide spectrum of relevant characteristics of the target trial population of the Generation Program. More recently and reported here for the first time, we developed a so-called joint model to fit the two outcomes together: cognition as captured by the APCC and TTE. The APCC part of the joint model is fitted on longitudinal observations of APCC via a mixed-effects model including demographic risk factors. The TTE part is fitted also adjusting for demographic risk factors, and with time-dependent APCC as a covariate to account for the hypothesized dependence of TTE on APCC decline. The estimated risk rates are therefore based on information from longitudinal APCC values. This approach is expected to deliver individual predictions for TTE that outperform predictions only using information at a specific timepoint (like baseline) and a fortiori, other approaches where a cut-off value on a continuous cognitive measure is used for predicting an event. In contrast to the first set of models used for simulation, the time scale of the APCC part of the joint model is not anchored at time of diagnosis and hence, has a more natural interpretation and can be used for risk prediction. Internal validation was performed through predictive checks for individuals and across the population. **Results:** For TTE model of the first approach, the predicted survival probabilities were adequately distributed around the observed Kaplan-Meier curves. Relevant diagnostic plots confirmed the quality and good predictive performance of the first approach APCC models. All models included important prognostic factors like APCC at study entry, APOE4 status, years of education, and age. From the simulated data pool of more than 200000 subject trajectories, we sampled up to n = 1000 clinical study populations for each scenario of interest to assess different trial design options. The joint model included terms for age at study entry, APOE4 status, and years of education as independent factors. The model-estimated time course of cognitive decline at both population and individual levels and overall time to diagnosis provided a good fit to the data. As expected, the model estimated a higher risk of developing MCI/AD symptoms for older subjects and for APOE4 carriers. **Conclusion:** The model based simulations enabled the optimal population definition for the AD prevention setting, and the assessment of the sensitivity of endpoints in early stages. This approach led to more realistic and scientifically driven trial designs and a greater probability of success of the Generation Program. The novel joint model provides a tool to dynamically estimate the individual risk of developing AD for cognitively unimpaired subjects who have longitudinal measures from sensitive neuro-psychological tests. Applied to data from the Generation Program and the iMAP study, this approach may lead to a better understanding of the predictive value and the clinical meaningfulness of early changes in APCC or other continuous measures of cognitive decline with regards to relevant long-term outcomes.

P145: ABILITY OF AN ONLINE OBJECT PATTERN SEPARATION TEST TO DETECT POTENTIAL DISRUPTIONS TO HIPPOCAMPAL NEUROGENESIS ASSOCIATED WITH AGEING, GENDER, LIFESTYLE AND DISEASE IN A LARGE COHORT OF OLDER ADULTS. Keith A. Wesnes^{1,2}, Helen Brooker^{1,2}, Clive Ballard¹, Dag Aarsland³, Zunera Khan³, Maria Megalogeni³, Anne Corbett¹ ((1) *University of Exeter Medical School, University of Exeter, Exeter, UK*; (2) *Wesnes Cognition Ltd, Stratley on Thames, UK* (3) *King's College London, London, UK*)

Background: Object Pattern Separation (OPS) tests have been demonstrated in man to have a measure sensitive to activity in the hippocampal dentate gyrus, one of the two brain areas where neurogenesis occurs. PROTECT is a UK based study being conducted entirely online, with the intention of following a large cohort volunteers aged 50 and over without dementia for 10 years (www.protectstudy.org.uk). The study involves annual assessments with a range of cognitive tests including a validated OPS test. **Objectives:** On study entry, volunteers provided a wide range of demographic, lifestyle and medical information. The purpose of this analysis is to determine factors which influence OPS in this population. **Methods:** The OPS test involves 20 very closely similar pairs of pictures of everyday scenes and objects. One of each pair is initially presented, and after a delay in which other tests are performed, the original pictures are mixed with the similar ones are presented in a counterbalanced order. For each picture, the volunteer has to decide whether or not it was the one shown earlier. It is the ability to correctly reject the closely similar pictures (often termed 'lures') which is sensitive to activity in the dentate gyrus, not the ability to correctly identify the original pictures. Thus, selective deficits to correct rejections of the lure pictures is consistent with compromised activity in the dentate gyrus. The test scores were evaluated using ANCOVAs to determine the effects of age, gender, lifestyle and various disease conditions. **Results:** OPS test data were available at study entry for 17,768 volunteers, 4,888 males (mean age 63.6 years, SD 7.7, range 50 to 93) and 12,880 females (mean age 61.2 years, SD 7.0, range 50 to 94). To confirm the sensitivity of the task to the known neurogenesis deficits which accompany ageing, the population was divided into 7 age-cohorts. The age-cohorts, type of stimuli and the interaction between them were fitted as separate factors to the ANCOVA model, along with covariates for gender and education. The interaction term confirmed a different profile of change of the two types of stimuli with ageing. This was evidenced as a marked and consistent age-cohort by cohort decline in the ability to detect the lure pictures, compared to virtually no change over the age-range for the original pictures. The detection rate of lure pictures declined by 16% ($p < 0.0001$; Cohen's $d = 1.44$) from the youngest (50 to 54 years) to the oldest cohort (80 to 93 years), in contrast to just under 1% for the originals ($p = 0.19$; Cohen's $d = 0.07$). To extend the finding, gender was introduced as a factor in the model. There were no gender differences for the ability to detect the original stimuli, but females were consistently superior to males in the ability to identify lure stimuli, the overall difference having an effect size of 0.24, the greatest difference occurring at 75 to 79 years with an effect size of 0.38. Further analyses of the population identified a variety of conditions which were associated with disrupted neurogenesis, notably Mild Cognitive Impairment ($d = 0.76$), Major Depression ($d = 0.49$), Parkinson's disease ($d = 0.48$) and Stroke ($d = 0.38$). Other conditions also

showed highly significant associations, but with smaller effect sizes, including diabetes ($d = 0.12$), high blood pressure ($d = 0.14$), and heart disease ($d = 0.13$). Further, smokers were found to show a decline on the neurogenesis sensitive measure compared to former and never smokers ($d = 0.25$). On the positive side, we have reported that exercise as well as performance of word and number puzzles has favourable effects on this measure, as does online brain training. **Conclusions:** Hippocampal neurogenesis plays a major role in cognitive function. The use of this online OPS task in such a large study has confirmed and extended previous findings, and identified further conditions in which neurogenesis may be compromised. This 10-year study will enable the longer-term implications of the various effects reported here to be evaluated. Further, PROTECT is designed to accommodate embedded trials, which will thus provide the opportunity to study treatments which could favourably affect hippocampal neurogenesis in this older population.

P146: COMPARISON OF SLEEP MEASUREMENTS FROM ACTIGRAPHY TO SELF-REPORTED SLEEP DIARIES. Kirsi Kinnunen¹, Richard Joules¹, Janet Munro¹, Iain Simpson¹, Robin Wolz^{1,2}, Yves Dauvilliers³ ((1) *IXICO Plc, London, UK*; (2) *Imperial College London, London - UK*; (3) *Sleep Unit, Department Neurology, Centre Hospitalier Universitaire, Montpellier, INSERM 1061 - France*)

Background: Sleep disturbances are common in people living with dementia. Reduced and fragmented sleep can impact pathology, worsen other symptoms, and significantly affect daytime functioning. Additionally, poor sleep quality may be a risk factor of many neurological conditions, including Alzheimer's disease (Ju et al. 2014). While polysomnography (PSG) remains the gold standard for sleep assessment, it is costly, often recorded on an isolated night with no daytime assessment, and may not be feasible in many clinical trials. The increasing availability of wearable sensor technology offers a practical, non-intrusive means of collecting continuous sleep-wake data, over several days. This provides "digital biomarkers" from real world settings that can be used to predict risk, detect symptoms and monitor changes in sleep and activity. **Objectives:** The aim of this study was to examine relationships between actigraphy-derived and self-reported sleep diary measurements within an epidemiology study cohort of elderly subjects. **Methods:** We analyzed actigraphy and sleep diary data, available for 22 subjects (Age: Mean=80.6, SD=9.9; 68% female) from a study of sleep difficulties, lifestyle factors and general health in the Centre Hospitalier Universitaire, Montpellier - France. All subjects were asked to wear an Axivity 3-axis accelerometry biosensor device (<http://axivity.com/>) on their non-dominant wrist for 14 nights and to complete sleep diaries for the same 2-week period. IXICO's fully integrated wearables work-flow (Figure 1) was employed for data analysis. This incorporated quality control (QC) for periods of perceived device "non-wear". In-bed periods were estimated with the McVeigh algorithm (McVeigh et al. 2016) and sleep and wake periods with the Cole-Kripke (CK) algorithm (Cole et al. 1992). Correlations between the actigraphy- and self-reported sleep measurements were assessed sample-wise, for all nights with both types of data available. As part of a quantitative QC, unrealistic night-time in-bed periods of <2.5 and >13 hours (N=17) were excluded from subsequent analysis, as well as self-reported nights with <1 hour of sleep (N=2). This resulted in 141 nights' data for the statistical analysis. Correlations

(Pearson's R/Spearman's Rho) were calculated between four variables available from both actigraphy and the diaries: sleep efficiency/quality, total time in bed, night-time in-bed sleep and number of awakenings. **Results:** Actigraphy-derived sleep efficiency correlated with self-reported sleep quality at $r = .16$ ($p = .06$; Figure 2). McVeigh-estimated times in bed at night and self-reported times from into-bed to out-of-bed correlated at $r = .32$ ($p = .0001$). CK-estimated in-bed sleep times and self-reported times from lights-out to awakening (minus sleep onset latency) correlated at $r = .15$ ($p = .07$). As expected, the number of estimated night-time awakenings was considerably higher from actigraphy (median=13, IQR=11) than from the diaries (median=2, IQR=2), with these measurements correlated at $r = .06$ ($p = .51$). **Conclusions:** The relatively low correlations between sleep diaries and actigraphy measures reported here may implicate poor reliability and inaccuracy of self-reported sleep measures (see e.g. Goelema et al. 2017). However, as self-reported awakenings may include lying still in bed, the higher number of actigraphy-derived awakenings may be partially explained by interpretation of the minute-wise sleep/no-sleep labeling from the algorithm: a period of wakefulness being split into several if quiet wakefulness is labelled as asleep. With sleep efficiency, we have previously shown in the same cohort that measures derived from 1-night accelerometry recordings using the CK algorithm (as above) correlated at $r = .61$ ($p = .003$) with simultaneous PSG (Wolz et al. 2017). Using a well-designed work-flow, actigraphy can provide objective real-world measures of sleep and activity from data collected over 14 days or longer, with minimal patient discomfort and acceptable QC failure rates. Although PSG can be used to assess sleep stages, apnea/hypopnea indexes and periodic leg movements, the advantages of actigraphy over traditional PSG include the well-tolerated continuous recording in real life settings and relative cost-effectiveness. The current results suggest that compared to sleep diaries, actigraphy can offer an attractive and more reliable alternative for the measurement of signs and symptoms of disease, or the evaluation of therapeutic effects. Customized data analytics, including disease-specific models, have the potential to detect sleep disturbance more accurately than widely used algorithms such as the CK, which may incorrectly interpret periods of quiet wakefulness as sleep. In the Wolz et al. (2017) 1-night study, we found the IXICO Deep Learning Sleep (DLS) algorithm to outperform the CK in estimating PSG-derived sleep efficiency (DLS: $r = .84$, $p < .0001$ vs. CK: $r = .61$, $p = .003$). Our approach of combining actigraphy with advanced data analytics shows promise for providing improved biomarkers of sleep, circadian rhythm and activity outcomes in clinical trials. In future work, we will employ the DLS algorithm to estimate sleep efficiency in elderly populations and neurodegenerative disease cohorts and will extend the presented statistical analysis to include daytime naps and an assessment of variability between night and day activity/sleep over the 14 day period. References: Cole et al. (1992). Automatic sleep/wake identification from wrist activity. *Sleep*, 12(5), 461-9. Goelema et al. (2017). Determinants of perceived sleep quality in normal sleepers. *Behavioural Sleep Medicine*, 20(1):1-10. Ju, et al. (2014). Sleep and Alzheimer disease pathology--a bidirectional relationship. *Nature Reviews Neurology*, 10(2), 115-9. McVeigh et al. (2016). Validity of an automated algorithm to identify waking and in-bed wear time in hip-worn accelerometer data collected with a 24 h wear protocol in young adults. *Physiological Measurement*, 37(10), 1636-52. Wolz et al. (2017). Extracting digital biomarkers of

sleep from 3-axis accelerometry using deep learning. *The Journal of Prevention of Alzheimer's Disease*, 4(4), P81.

P147: USING DCTCLOCK'S CLINICALLY-INTERPRETABLE ARTIFICIAL INTELLIGENCE FOR DIFFERENTIATING COGNITIVELY HEALTHY SUBJECTS FROM AMNESTIC MILD COGNITIVE IMPAIRMENT AND PROBABLE ALZHEIMER'S DISEASE. William Souillard-Mandar¹, Braydon Schaible¹, Randall Davis^{1,2}, Rhoda Au³, Dana Penney^{1,4} ((1) *Digital Cognition Technologies, Inc., Waltham, MA, USA*; (2) *MIT Computer Science and Artificial Intelligence Laboratory, Cambridge, MA, USA*; (3) *Boston University Schools of Medicine and Public Health, Boston, MA, USA*; (4) *Lahey Hospital and Medical Center, Burlington, MA, USA*)

Background: DCTclock™ is an FDA-cleared tool that transforms the traditional Clock Drawing Test into an automated, sensitive cognitive screener that rapidly detects and quantifies subtle cognitive decline. Administered using a digitizing ballpoint pen, software analyzes the entire drawing process, extracts meaningful cognitive features, constructs composite scales (Drawing Efficiency, Information Processing, Spatial Reasoning, and Simple and Complex Motor) and produces an overall score. We examine the ability of DCTclock algorithms to detect and distinguish cognitively healthy (CH) from amnesic Mild Cognitive Impairment (aMCI) and probable Alzheimer's disease (AD). **Methods:** DCTclock was administered to 512 dementia-free and stroke-free Framingham Heart Study participants (MMSE=29) and 123 Lahey Hospital and Medical Center subjects with a consensus diagnosis of aMCI ($n=56$; MMSE= 27) or probable AD ($n=67$; MMSE=21), determined using medical records review, neurological evaluation, neuropsychological testing, and neuroimaging. Group differences were tested using the Kruskal-Wallis test; post-hoc analyses were conducted using the Wilcoxon Rank Sum test, adjusting for multiple comparisons using the Bonferroni-Holm method. DCTclock scores' ability to differentiate between the groups was studied using ROC analysis. **Results:** DCTclock score (0-100) differentiates all groups ($p<0.001$, CH=86.23, aMCI=48.50, AD=15.45). DCTclock score classification accuracy was high for all group comparisons: CH and aMCI (AUC=0.84); CH and AD (AUC=0.94); aMCI and AD (AUC=0.79). There were significant differences ($p<0.05$) in the expected direction between all groups on both command and copy scores measuring drawing efficiency and spatial reasoning. CH and aMCI were similar for both conditions on information processing composite score ($p=0.095$), but differed from AD ($p<0.001$). Command and copy motor control composite scores differed between CH and aMCI ($p<0.001$), but aMCI and AD were similar ($p=0.148$). **Conclusion:** DCTclock score demonstrates classification accuracy across the impairment spectrum from cognitively healthy to mild dementia in this sample. Differences in drawing efficiency and spatial reasoning between CH and aMCI suggest subjects work harder and produce less in early stage impairment, with processing difficulties more prominent in mild dementia. The ability to detect subtle cognitive impairment holds promise for improving prescreening of subjects into AD clinical trials, while simultaneously characterizing discrete cognitive functions to provide novel metrics for assessing treatment efficacy.

Table 1

Summary of DCTclock score and composite scores stratified by diagnosis

Variable	Cognitively Healthy	P-Value	aMCI	P-Value	AD
Sample Size	512		56		67
MMSE Score	29.00 [29.00, 30.00]	<0.001	27.00 [25.25, 29.00]	<0.001	21.00 [19.00, 23.00]
DCTclock Score	86.23 [71.79, 93.68]	<0.001	48.50 [38.80, 68.40]	<0.001	15.45 [6.36, 39.94]
Command Clock					
<i>Drawing Efficiency</i>	0.16 [-0.51, 0.66]	<0.001	-0.54 [-1.75, 0.11]	0.002	-1.98 [-3.56, -0.66]
<i>Spatial Reasoning</i>	0.31 [-0.39, 0.68]	<0.001	-0.86 [-2.21, 0.12]	<0.001	-3.57 [-4.17, -2.39]
<i>Information Processing</i>	0.19 [-0.49, 0.75]	0.095	-0.26 [-1.01, 0.56]	<0.001	-1.55 [-3.10, -0.45]
<i>Motor Control</i>	0.24 [-0.48, 0.82]	<0.001	-0.74 [-1.50, 0.09]	0.148	-1.17 [-2.30, -0.29]
Copy Clock					
<i>Drawing Efficiency</i>	0.10 [-0.41, 0.58]	0.008	-0.15 [-1.58, 0.36]	<0.001	-1.51 [-3.40, -0.42]
<i>Spatial Reasoning</i>	0.27 [-0.63, 0.80]	<0.001	-1.37 [-1.75, -0.21]	0.005	-2.01 [-3.16, -1.09]
<i>Information Processing</i>	0.16 [-0.59, 0.74]	0.095	-0.07 [-0.98, 0.45]	<0.001	-1.42 [-2.25, -0.15]
<i>Motor Control</i>	0.14 [-0.44, 0.68]	<0.001	-0.44 [-1.41, 0.15]	0.148	-0.95 [-1.64, 0.03]

Figure 1

ROC curves for discrimination of specific diagnoses

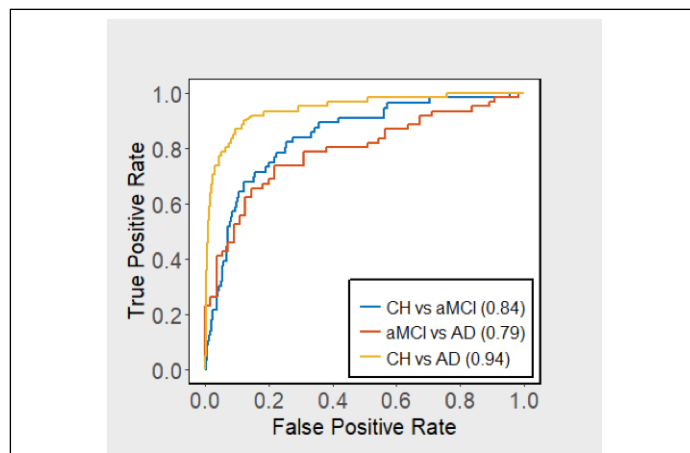

P148: ADVANCING CLINICAL AND BIOMARKER RESEARCH IN AD: THE LEAD STUDY.

Liana G. Apostolova, Paul Aisen, Ani Eloyan, Anne Fagan, Tatiana Foroud, Constantine Gatsonis, Clifford Jack, Joel Kramer, Robert Koeppe, Andrew Saykin, Arthur Toga, Prashanthi Vemuri, Gregory Day, Neill Graff-Radford, Lawrence Honig, David Jones, Sterling Johnson, Joseph Masdeau, Mario Mendez, Chiadi Onyike, Emily Rogalski, Steve Salloway, David Wolk, Thomas Wingo, Maria Carrillo, Brad Dickerson, Gil Rabinovici

Background: Approximately 5% of the 5.6 million (~280,000) Americans with Alzheimer’s disease (AD) develop symptoms at age 65 or younger and are classified as having early-onset AD (EOAD). Although EOAD and late-onset AD (LOAD) share the same pathologic substrate, there are notable differences in their clinical and biological phenotypes. Compared to LOAD, patients with sporadic EOAD show more rapid cognitive decline and lower prevalence of amnestic versus non-amnestic clinical presentations. EOAD is associated with greater baseline cortical atrophy/hypometabolism, less medial temporal lobe involvement and more severe AD pathology than LOAD. EOAD patients present with a relatively “pure” form of AD because of lower rates of age-related brain co-pathologies. Furthermore, studies suggest high heritability in EOAD in the absence of known mutations or APOE4, signifying that

this population may be enriched for novel genetic risk factors. EOAD patients often face a significant delay to diagnosis, access to AD treatments, and social and financial support services. Despite being highly motivated and having few comorbidities, EOAD patients are commonly excluded from large scale observational biomarker studies (e.g. ADNI and DIAN) and therapeutic trials due to their young age, non- amnestic deficits, or absence of known pathogenic mutations. **Objective:** Our over-arching goals are to 1) advance our knowledge about AD diagnosis, 2) develop sensitive composite clinical and biomarker tools that capture disease progression in this unique cohort for implementation in clinical trials, 3) to establish a network of EOAD sites ready to launch interventional studies in this population; and 4) explore possible genetic susceptibility factors through GWAS. **Methods:** Leveraging existing infrastructure and processes applied in ADNI and DIAN, we have launched the Longitudinal Early-onset AD study (LEADS) - a multi-site, observational clinical and biomarker study of EOAD. We plan to recruit and longitudinally follow 400 amyloid PET-positive EOAD subjects meeting NIA-AA criteria for MCI due to AD or probable AD dementia (including primary amnestic, dysexecutive, language and visuospatial presentations) and 100 age-matched controls. LEADS participants will undergo clinical assessments, psychometric testing, MRI, amyloid ([18F] Florbetaben) and tau ([18F]AV1451) PET, CSF and blood draw for collection of DNA, RNA, plasma, serum and peripheral blood mononuclear cells (PBMC). EOAD participants will be assessed at three time points. Methods will be harmonized with ADNI and DIAN. We will comprehensively characterize cognitive, imaging and biofluid changes over time in EOAD, and compare to a matched sample of LOAD participants identified in ADNI. We will employ machine learning algorithms to develop sensitive clinical and imaging measures of EOAD progression. An exploratory aim will apply next generation sequencing to assess for novel genetic risk factors for disease. **Results:** We will present an overview of the study design and will report the demographic, clinical and biomarker characteristics of participants enrolled through October 1, 2018. **Conclusions:** Successful completion of this project will address several substantial gaps in our understanding of EOAD and AD research in general. Importantly, patients with EOAD are outstanding clinical trial candidates, as they present a “pure” form of AD, tend to be otherwise healthy, and show more rapid progression on cognitive and imaging measures, allowing for the detection of a potential disease modifying drug effect in a short amount of time. This project will facilitate these trials by developing a publicly available natural history dataset of biomarker and clinical inclusion and outcome measures suited for the EOAD population and will establish a network of EOAD sites that will enable future planning and implementation of clinical trials in EOAD.

P149: MEASURING PRE-CLINICAL COGNITIVE DECLINE OVER TIME: SEPARATING AND COMBINING ALZHEIMER'S SPECIFIC DECLINE AND COGNITIVE DECLINE RELATED TO AGING IN COGNITIVE COMPOSITE SCORES. Suzanne Hendrix¹, Noel Ellison¹, Jessica B. Langbaum², Kewei Chen³, David A. Bennett⁴ ((1) *Pentara Corporation, Millcreek, UT, USA*; (2) *Arizona Alzheimer's Consortium, Phoenix, AZ, USA*; (3) *University of Arizona, Tucson, AZ, USA*; (4) *Rush University, Chicago, IL, USA*)

Background: Measuring progression in the pre-clinical stage of Alzheimer's disease presents unique challenges due to ceiling effects, subject heterogeneity, and within patient variability. Normal aging effects are particularly relevant in this stage of disease since the disease-related changes are of the same magnitude as the normal aging effects. In addition, some clinical trial interventions may be hypothesized to affect only disease related changes, only normal aging, or both, requiring different approaches for each of these measurement goals. The APCC was empirically derived to measure very early AD related change by maximizing the signal to noise ratio of the change over time in those later diagnosed with AD corrected for normal aging. **Objectives:** 1. Analyze Alzheimer's data in a multivariate way with appropriate plots for displaying analysis results. 2. Understand the value of composite scores for measuring AD progression and cognitive aging in early AD. 3. Interpret 3-D figures corresponding to principal components analysis of preclinical Alzheimer's data in terms of variable relationships, and group differences. **Methods:** A principal components analysis (PCA) was performed and graphed on Neuropsychological Test Battery (NTB) items, with and without ADLs (Lawton Brody scale), using data from older participants in 3 cohorts from the Rush AD Center who started out with normal cognition. The analysis was performed once with baseline scores and once with change from baseline scores at 4 years. Baseline age was also included to account for differences due to age. Means were compared between genders and future MCI and AD patients and those who remained normal. **Results:** The most prominent feature of the plot of the absolute scores including cognition and ADLs at each visit was the gender difference on ADL scores with females having more variability in items associated with factor 2 (ADLs, especially cleaning and walking) than males. This variability was more aging related than disease related, and involved less than 10% of females. Factor 1 was associated with NTB items, and factor 3 was associated with MMSE items. The figure showing changes at 4 years in cognition and ADLs had one factor associated with MMSE items, one associated with NTB items and one associated with function. Females tended to decline on NTB items when diagnosed with AD, and males tended to decline on MMSE items. Both groups moved toward functional impairment with AD diagnosis. **Conclusions:** A graphical display of factor loadings clearly separates ADLs and cognitive items, and shows age, gender and diagnosis group differences associated with each factor. Complex relationships between subgroups across multiple related outcome measures are easier to understand.

Theme: Cognitive assessment and clinical trials

P6: EVALUATION OF TITERS OF ANTIBODIES AGAINST PEPTIDES OF SUBUNITS NR1 AND NR2B OF GLUTAMATE RECEPTOR BY ENZYME-LINKED IMMUNOSORBENT ASSAY IN PSYCHIATRIC PATIENTS WITH ANTI-THYROID ANTIBODIES. Takahiro Ikura (*Yokohamacity Univercsity Psychiatry*)

Background: Patients with anti-thyroid antibodies (ATAs) are reported to exhibit atypical psychiatric symptoms. We have been reported that psychiatric patients with ATAs (PPATs) have anti-N-methyl-D-aspartate (NMDA) type glutamate receptor (NMDA-R) antibodies by western blot analysis. NMDA-R forms a tetramer with the subunit glutamate receptors (GluR) GluR ϵ 1 (NR1) and GluR ϵ 2 (NR2B). However, the possible etiological role of anti-NR1 and anti-NR2B antibodies in PPATs remains unclear. **Methods:** First, we evaluated titers of anti-NR1 and anti-NR2B antibodies in PPATs by enzyme-linked immunosorbent assay (ELISA). Next, we investigated the relationships among titers of anti-NR1 and anti-NR2B antibodies. Finally, we investigated the relationship between anti-NMDA-R antibodies and the psychiatric symptoms in the PPATs. **Results:** There was a strong correlation between anti-NR1 antibodies and anti-NR2B antibodies in the CSF, and some correlation between these antibodies in the serum. High titers of anti-NR2B antibodies in the serum of PPATs contributed to development of hallucinations by linear regression analysis. **Conclusion:** High titers of anti-NR2B antibodies in the serum is a risk factor for hallucinations in PPATs.

P14: ANOSOGNOSIA IN MILD COGNITIVE IMPAIRMENT AND DEMENTIA. Dong Won Yang¹, Ahro Kim¹, Dong Woo Lee², Hyun Jeong Han³, Jee Hyang Jeong⁴, Jun Hong Lee⁵, Jun-Young Lee⁶, Kee Hyung Park⁷, Kyung Won Park⁸, SangYun Kim⁹, Seong Hye Choi¹⁰, Young Chul Youn¹¹ ((1) *Department of Neurology, Catholic University of Korea, Seoul, Korea*; (2) *Department of Psychiatry, Inje University Sanggye Paik Hospital, Seoul, Korea*; (3) *Department of Neurology, Myongji Hospital, Goyang*; (4) *Department of Neurology, Ewha Womans University Mokdong Hospital, Ewha Womans University School of Medicine, Seoul*; (5) *Department of Neurology, National Health Insurance Corporation Ilsan Hospital, Goyang*; (6) *Department of Psychiatry and Neuroscience Research Institute, Seoul National University College of Medicine & SMG-SNU Boramae Medical Center, Seoul, Republic of Korea*; (7) *Department of Neurology, Gachon University Gil Hospital, Incheon, South Korea*; (8) *Department of Neurology, Cognitive Disorders and Dementia Center, Dong-A University College of Medicine, Busan, South Korea*; (9) *Department of Neurology, Seoul National University College of Medicine, Seoul National University Bundang Hospital, Seongnam, South Korea*; (10) *Department of Neurology, Inha University School of Medicine, Incheon, South Korea*; (11) *Department of Neurology, Chung-Ang University Hospital, Seoul, Korea*)

Background & Objectives: Anosognosia in dementia represented as a lack of awareness of impairment in cognition and the inability in daily activity of living. Anosognosia is a risk factor in MCI for the conversion to dementia and aggravated as disease progresses. We investigated anosognosia in MCI and dementia with different severity spectrum. **Methods:** 400 subjects (200 healthy controls, 50 MCI, 120 AD, 50 other dementias) over 65 years old and their caregivers were recruited

for this study. Korean Dementia Screening Questionnaire-cognition (KDSQ-C), Alzheimer's disease 8(AD8), and Subjective Memory Complaints Questionnaire (SMCQ) were rated separately by patients and their caregivers to evaluate their functions of cognition and the capability in activity of daily living. Mini-Mental State Examination (MMSE) was conducted to evaluate patient's global cognition. Discrepancy of scores of 3 different questionnaires between patients and their caregivers (Caregiver rated scores - Patient rated scores) was considered as severity of anosognosia. **Results:** Scores of questionnaires rated by patients were lower than the scores rated by their caregivers in MCI and dementia with different severity, clinical dementia rating (CDR) 0.5, 1 and 2. Two questionnaires (KDSQ-C, SMCQ) scores rated by patients were significantly higher than the caregiver's scores in NC. MMSE score decreased and caregiver rated questionnaire scores increased continuously from NC to dementia with CDR 0.5, 1 and 2. Questionnaire scores rated by patients were also increased from NC to dementia with CDR 1; however the scores decreased in moderate dementia (CDR 2). Severity of anosognosia correlated well with CDR and MMSE. **Conclusions:** Anosognosia could be detected even in MCI state and its severity was sustained in dementia with CDR 0.5. However, it became aggravated in mild dementia with CDR 1 and became worse in moderate dementia with CDR2. Caregivers may underestimate or subjects themselves overestimate their cognitive dysfunction in normal controls. We should be aware of anosognosia in MCI and mild dementia patients when interpret their self-reported dysfunctions.

P24: CLINICAL CORRELATES OF TYPES OF MEMORY COMPLAINTS IN MILD COGNITIVE IMPAIRMENT. Seon Young Ryu, Sang Bong Lee, Taek Jun Lee, Yu Jin Jung (Neurology Department, Daejeon St. Mary's Hospital, College of Medicine, The Catholic University of Korea, Daejeon, South Korea)

Background: Memory complaints are a frequent phenomenon in patients with mild cognitive impairment (MCI). Those memory complaints may reflect various aspects of the cognitive symptoms. **Objectives:** The aim of this study was to examine whether there are the differences of the clinical correlates due to different aspects of memory complaints (i.e. prospective memory (PM) versus retrospective memory (RM) complaints) in individuals with MCI. **Methods:** The study included a total of 152 participants (mean age: 68.16 ± 8.76 years) with MCI. Memory complaints were assessed using the Prospective and Retrospective Memory Questionnaire (PRMQ) consisting of 16 items which describe everyday memory failure of both PM and retrospective memory RM. Participants were divided into more PM complainers ($PM > RM$; $n = 93$) and more RM complainers ($PM \leq RM$; $n = 59$) according to the PM and RM subscores of PRMQ. All participants underwent clinical assessment and completed detailed neuropsychological tests. **Results:** There were no differences of depressive symptoms and instrumental activities of daily living between more PM and RM complainers group. Among cognitive measures, more RM complainers had lower verbal memory performance than more PM complainers. **Conclusions:** This study suggests that RM complaints among subjective memory complaints are more associated with decreased verbal memory performance in individuals with MCI. These results could inform diagnostic approaches to the clinical evaluation of memory complaints in individuals with MCI.

P29: A COMPARISON BETWEEN BRIEF EPISODIC MEMORY AND SEMANTIC MEMORY TASKS WITHIN A SCREENING TEST FOR MILD COGNITIVE IMPAIRMENT. Pamela Voccia, Katherine Kruczek (Bioclinica Research, The Villages, FL USA)

Background: Aptest, a memory screening tool developed for use at Bioclinica Research, has been administered to over 900 subjects between the ages of 65 and 85 who presented for consideration in Alzheimer's Dementia (AD) research trials. Trends in recent AD research suggest that tasks measuring Semantic memory may be more sensitive to Mild Cognitive Impairment (MCI) than tasks measuring Episodic memory. In an effort to maximize sensitivity of Aptest, an Episodic memory subtest was replaced with a Semantic memory subtest, and measures of Episodic and Semantic memory were compared for sensitivity to MCI. **Methods:** From March 2017 through November 2017, 293 subjects were given a version of Aptest that contained a narrative Episodic memory subtest. From December 2017 through May 2018, 628 subjects were given a version of Aptest that replaced the Episodic memory subtest with a Semantic category memory subtest. The Episodic memory subtest was comprised of a brief personal narrative read by the test administrator, which was then measured by delayed recall of 7 scorable facts. The Semantic memory subtest was comprised of a brief measure of categorical word retrieval and was administered in two separate cohorts, with either a 10 second or a 20 second task. Scores on the Episodic memory and Semantic memory subtests were compared to an alternative memory composite on Aptest that did not include Episodic or Semantic subtests. Subsequent Clinical Dementia Rating (CDR) scores were compared to subject performance on Episodic memory subtests ($n=76$) and Semantic memory subtests ($n=73$). A correlation coefficient (r) was derived for each comparison. Subjects data was further divided by a blinded rater into two cohorts, Normal vs MCI (determined by an Aptest triage score of >24), and the means were compared using t-test analysis. Episodic and Semantic memory were further compared to overall Aptest memory scores, to determine the influence of the measures on the overall score. **Results:** For both the 20 second and 10 second Semantic memory task, there was a significant discrepancy between the means of scores for Normal vs MCI groups. [$t(10\text{second}) = 12.11$, $t(20\text{second}) = 9.99$; t critical = 1.98]. When Episodic memory was compared for the Normal vs MCI groups, there was also a statistically significant discrepancy between the means ($t=11.87$, critical = 1.97). Both Episodic and Semantic memory correlated moderately to performance on the alternative memory composite (Episodic Memory $r = 0.59$; Semantic Memory $r = 0.45$). Both Episodic and Semantic memory correlated moderately with subsequent CDR ratings. (Episodic Memory $r = -0.51$; Semantic Memory $r = -0.43$). When comparing Normal vs MCI groups, there was a low correlation between performance on tests including Episodic memory tasks and overall Aptest memory for the Normal group ($r = 0.28$), but a high correlation between performance on Episodic memory tasks and overall memory performance in the MCI group ($r = 0.729$). In contrast, Semantic memory did not yield significant differences in correlation coefficients between Normal and MCI groups when compared to overall Aptest memory score (Normal $r = 0.45$, MCI $r = 0.58$). **Conclusion:** The purpose of this study was to evaluate brief Semantic and Episodic memory tasks in an effort to improve the sensitivity of a memory screening test to MCI. In this comparison between a brief

narrative Episodic memory task and a brief Semantic category memory task, it appeared that both tasks correlated moderately to overall memory performance. While Semantic memory yields moderate correlations for both Normal and MCI groups, Episodic memory appears to be significantly more sensitive to memory performance in MCI subjects. Perhaps most interesting is the finding that Semantic memory is as sensitive, if not more, at a 10 second measure as it is at a 20 second measure, which indicates that it can be used reliably in a brief memory screening. The moderate correlations may have been negatively affected by the brevity of the subtests. The results of this study suggest the need for further investigation into various lengths of Episodic and Semantic memory subtests, to optimize the validity and brevity of memory screenings for detecting Mild Cognitive Impairment.

P33: COMPARATIVE EVALUATION OF TESTS FOR THE COGNITIVE DYSFUNCTION SCREENING IN THE NATIONAL MEDICAL CHECK-UP. Ahro Kim¹, Dong Won Yang¹, Dong Woo Lee², Hyun Jeong Han³, Jee Hyang Jeong⁴, Jun Hong Lee⁵, Jun-Young Lee⁶, Kee Hyung Park⁷, Kyung Won Park⁸, SangYun Kim⁹, Seong Hye Choi¹⁰, Young Chul Youn¹¹ ((1) Department of Neurology, Seoul St. Mary's hospital, Catholic University of Korea, Seoul, Korea; (2) Department of Psychiatry, Inje University Snaggye Paik Hospital, Seoul, Korea; (3) Department of Neurology, Myongji Hospital, Goyang; (4) Department of Neurology, Ewha Womans University Mokdong Hospital, Ewha Womans University School of Medicine, Seoul; (5) Department of Neurology, National Health Insurance Corporation Ilsan Hospital, Goyang; (6) Department of Psychiatry, Seoul National University Boramae Hospital, Seoul, Korea; (7) Department of Neurology, Gachon University Gil Hospital, Incheon, South Korea; (8) Department of Neurology, Cognitive Disorders and Dementia Center, Dong-A University College of Medicine and Institute of Convergence Bio-Health, Busan, South Korea; (9) Department of Neurology, Seoul National University College of Medicine, Seoul National University Bundang Hospital, Seongnam, South Korea; (10) Department of Neurology, Inha University School of Medicine, Incheon, South Korea; (11) Department of Neurology, Chung-Ang University Hospital, Seoul, Korea)

Background: Background & Objective: With the rate of growth of the aged population, dementia has emerged as a major health problem in South Korea. In Korea there is health screening test for dementia which is covered by the National Health Insurance. There are several screening tools for dementia. We investigated which screening test is effective for screening cognitive impairment in periodic health screening by National Health Insurance. **Methods:** A total of 392 subjects (189 healthy controls, 48 Mild cognitive impairment (MCI), 113 Alzheimer disease (AD), 113, other dementias 42) over 65 years old and their caregivers from 11 hospitals were recruited for this study. All patients were grouped into normal cognition, MCI and dementia subgroups. Korean Dementia Screening Questionnaire-cognition (KDSQ-C), Alzheimer's disease 8(AD8), and Subjective Memory Complaints Questionnaire (SMCQ) were rated separately by patients and their caregivers to evaluate their functions of cognition and the capability in activity of daily living. Mini-Mental State Examination (MMSE-DS) was conducted to evaluate patient's global cognition. We calculated sensitivity and specificity of each questionnaires and MMSE and also estimated receiver operating characteristic (ROC) curve. Retest was done after 1 month. **Results:** For

questionnaires rated by patients, ROC analysis showed that the area under the curve (AUC) for the AD8 in diagnosing dementia was 0.8. AUC for KDSQ-P was 0.71 and AUC for KDSQ-C was 0.74, and AUC for SMCQ was 0.72. In other hands, for questionnaires rated by caregivers there was no difference and all tools showed high AUC values for diagnosing dementia (AUC for KDSQ-P was 0.91, AUC for KDSQ-C was 0.92 AUC for AD8, SMCQ was 0.93). With respect to a diagnosis of dementia by patients, the KDSQ-C (cut-off point 6) had a sensitivity of 63% and a specificity of 76%. The AD-8(cut-off point 2) had a sensitivity of 71% and a specificity of 75%. The SMCQ (cut off point 4) had a sensitivity of 67% and a specificity of 70%. The KDSQ was found to have a high test-retest reliability ($r=0.81$). With respect to a diagnosis of dementia by caregivers, the KDSQ-C (cut-off point 9) had a sensitivity of 79% and a specificity of 92%. The AD-8(cut-off point 2) had a sensitivity of 90% and a specificity of 81%. The SMCQ (cut off point 5) had a sensitivity of 82% and a specificity of 86%. All tools was found to have a high test-retest reliability ($r=0.76$ for KDSQ-P, 0.82 for KDSQ-C, 0.76 for AD8, SMCQ for 0.77) especially for caregivers($r=0.80$ for KDSQ-P, $r=0.87$ for KDSQ-C, $r=0.86$ for AD8, $r=0.91$ for SMCQ). **Conclusions:** When diagnosing dementia, questionnaires by caregivers showed superior result than questionnaires by patients. All tool showed high sensitivity and specificity without significant differences. In regard of questionnaires by patient, AD8 showed higher AUC values than KDSQ-C or SMCQ. But there was no significant difference for KDSQ-C vs. SMCQ. Therefore, AD8 seems to be most effective for screening cognitive impairment in periodic health screening.

P34: A MULTICENTRE, PILOT STUDY TO EVALUATE AN AUGMENTED REALITY TEST (ALTOIDATM) FOR MILD COGNITIVE IMPAIRMENT DETECTION. Mircea Balasa^{1,2}, Adrià Tort-Merino¹, Ioannis Tarnanas^{2,3}, David Bartrés-Faz⁴, Rory Boyle⁵, Laura Rai⁵, Rob Whelan^{2,5}, Raquel Sanchez-Valle¹ ((1) Alzheimer's Disease and other Cognitive Disorders Unit, Neurology Department, Hospital Clinic, Barcelona, Spain; (2) Global Brain Health Institute, Trinity College Dublin, Dublin, Ireland; (3) Altoida AG, Lucerne, Switzerland; (4) Departament de Medicina, Faculty of Medicine and Health Sciences, University of Barcelona; (5) School of Psychology, Trinity College Dublin, Dublin, Ireland)

Background: The early identification of the first signs of cognitive decline in mild cognitive impairment (MCI) has long been considered critical for providing an adequate diagnostic and prognostic assessment and for implementing early and potentially more effective pharmacological and non-pharmacological interventions. Currently-available neuropsychological tests are mostly non-ecologic, time-consuming and expensive. For that reason, the development of new sensitive, easy-access and self-administered cognitive measures could provide the opportunity to track the earliest cognitive changes in large population samples and to obtain massive data for both research and diagnosis purposes. We aimed to evaluate a self-administered Augmented Reality (AR) tool in subjects with incipient cognitive decline (MCI). **Methods:** The ALTOIDATM software, administrable by means of a tablet in less than 10 minutes, evaluates visual-spatial memory and executive function. It consists in placing three-dimensional virtual objects in a real environment (Image 1) with their subsequent recovery after a distraction task. It contains two subtests: Back-in-time (BIT, which includes a simple auditory interference) and Day-Out-Task (DOT; which includes

a “Go/No-Go” type interference). Forty-six non-demented subjects were recruited and underwent clinical, cognitive and functional assessment at two different study sites. Eighteen cognitively normal elders conformed the control group (age: 65.4, MMSE: 29.4, range: 28-30, CDR 0). Subjects with MCI (CDR 0.5) were classified based on their CSF AD biomarker profile, as prodromal AD (Prod-AD; n = 18; age: 67.7; MMSE: 24.4, range: 20-29) and non-AD amnesic MCI (aMCI; n = 10; age: 61.8; MMSE: 26.9, range: 23-29). From the panel of ALTOIDATM outputs, we chose the time (seconds) required to perform the two tasks as proxies for global cognition. Between-group differences were analyzed using mixed-model ANCOVAs controlling for age and years of education. Non-Parametric correlations between demographics, cognition (Mini-Mental State Examination, MMSE), function (Clinical Dementia Rating – Sum of Boxes score, CDR-SB) and biomarkers results and the time required to perform the ALTOIDATM tasks were performed. Additionally, in MCI subjects, a self-administered questionnaire evaluating the perceived invasiveness of the conventional neuropsychological assessment and the augmented reality tool was administered at the end of the study procedures. Subjects were asked to rate on a scale from 0 to 10 (none to extreme) the degree of discomfort involved when performing the study procedures. **Results:** Distinct patterns of CSF biomarkers were observed between Prod-AD (CSF A β 42: 519.1 \pm 111.6 pg/ml, CSF tau: 567.6 \pm 213.8 pg/ml and CSF ptau: 85.6 \pm 26.2 pg/ml) and aMCI groups (CSF A β 42: 912.2 \pm 198.6 pg/ml, tau: 208.4 \pm 109.2 pg/ml and ptau: 41.7 \pm 18.5 pg/ml). The execution time on BIT and DOT tasks discriminated between cognitively normal subjects and the MCI groups: Prod-AD (F(1,32)=32.95; p<0.01 and F(1,32)=40.31; p<0.01, respectively) and aMCI (F(1,24)=16.63; p<0.01 and F(1,32)=25.06; p<0.01), with the control group showing better performance. We did not find differences on BIT and DOT between the two MCI groups (F(1,24)=1.01; p=0.325 and F(1,24)=1.47; p=0.237). The performance in BIT (Fig. 2A) and DOT (Fig. 2B) correlated with MMSE (r= -.639, p<0.01 and r= -.745, p<0.01) and with the CDR-SB score (r= .618, p<0.01 and r= .515; p<0.01), showing a clear association with the degree of cognitive decline. Additionally, correlation analyses in symptomatic subjects regarding the association between BIT and DOT performance and specific cognitive domains showed the strongest correlations with the executive functions domain (r= .574, p<0.01 and r= .512, p<0.01). We did not find correlations between the time required to perform the two ALTOIDATM tasks and the years of education or the CSF biomarkers. There was a trend for the participants to perceive ALTOIDATM test as less invasive than conventional neuropsychology (mean invasiveness score 2 vs 3 points; t(27)= -1.939, p=0.06). **Conclusions:** The existence of effective population screening tools for incipient cognitive decline is crucial for testing new disease modifying pharmacological and non-pharmacological strategies. ALTOIDATM discriminates between normal cognitive performance and MCI. It seems to be a rapid, ecological, well-accepted and more economic test than conventional neuropsychology and, in case of complete validation, opens the doors to large-scale population screening.

Figure 1
Screenshot of the ALTOIDA’s BIT task

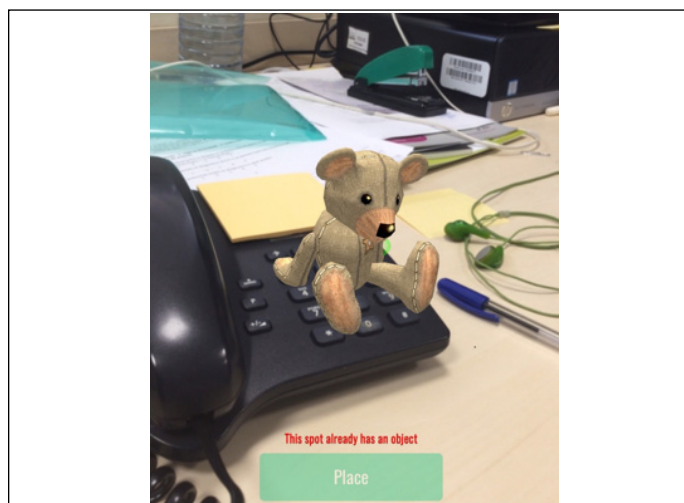
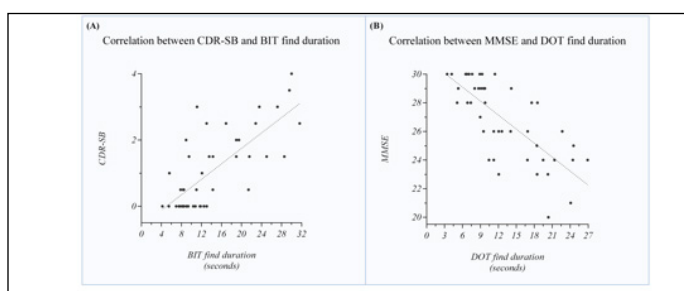

Figure 2
Correlation between functional (CDR-SB) and cognitive (MMSE) measures and the ALOTIDA outcomes



Key: CDR-SB: Clinical Dementia rating - Sum of Boxes score; BIT: Black-in Time; MMSE: Mini-Mental State Examination; DOT: Day-Out-Task

P41: COGNITIVE IMPAIRMENT UNDER TREATMENT WITH 2ND AND 3RD GENERATION ANTIHISTAMINES IN ELDERLY SUBJECTS. Georg Adler, Nadja Baumgart (Institut für Studien zur Psychischen Gesundheit, Mannheim, Germany)

Background: Brain histamine is involved in the regulation of arousal, cognition, and memory mainly through interactions with histamine H1 receptors. Histamine H1 antagonists often prescribed for treatment of allergic disorders, may induce sleepiness and cognitive deficits. Sedation as a consequence of treatment with 1st generation antihistamines has led to the development of 2nd and 3rd generation antihistamines, which are thought to be free of cognitive side effects. This proved to be true in studies on the cognitive effects of single doses in healthy volunteers. However, the relationship between treatment with 2nd or 3rd generation antihistamines and cognitive performance so far has not been examined within a naturalistic study under everyday conditions. This may be relevant for Alzheimer’s disease treatment studies, because cognitive side effects as a consequence of treatment with 2nd or 3rd generation antihistamines may act as a confounding variable. **Objective:** To assess cognitive side effects of treatment with 2nd and 3rd generation antihistamines in subjects with chronic spontaneous urticaria (CSU). **Methods:** 250 CSU patients were assessed in 15 dermatological practices and outpatient clinics in Germany. Severity of disease was assessed

by means of the Urticaria Activity Score (UAS-7) and the Urticaria Control Test (UCT), quality of life by the Dermatology Life Quality Index (DLQI) and the Chronic Urticaria Quality of Life Questionnaire (CU-Q2oL). Cognitive performance was studied by means of the computer-based Memory and Attention Test (MAT). Sociodemographic data, current medication in treatment categories, comorbidities, obesity, smoking and drinking habits are taken by a questionnaire. **Results:** The effect of antihistamines was assessed separately for patients aged between 18 and 60 years (mean: 40.5 years) and patients between 61 and 80 years (mean: 67.9 years). In patients under treatment with 2nd or 3rd generation antihistamines (n=134 or 27 resp.) compared to patients not under treatment with antihistamines (n=47 or 6 resp.), we found a significant impairment of episodic working memory for both age groups. The impairment was found independently whether antihistamines were applied at dosages licensed for treatment or at higher dosages. Episodic short-term memory and selective attention were unimpaired. **Conclusions:** Treatment with 2nd or 3rd generation antihistamines may be associated with cognitive impairment, particularly in elderly patients. This effect should be considered regarding the handling of concomitant medications in Alzheimer's disease treatment trials.

P42: USING BAYESIAN METHODS TO MODEL NORMATIVE CANTAB COGNITION DATA ACROSS ADULTHOOD. Pasquale Dente¹, Elizabeth Baker¹, Jack Cotter¹, Francesca Cormack¹, Jennifer H Barnett^{1,2} ((1) *Cambridge Cognition Limited, Cambridge, UK*; (2) *University of Cambridge, Cambridge, UK*)

Background: Interpretation of cognitive test score performance requires evaluation within the context of general population performance, across age, gender and educational ability. Typically, normative data are described by grouped means, which may lead to unreliable estimates when sample sizes are small within certain demographic groups. This study uses an innovative method including Bayesian techniques to incorporate information on age distribution and capture cognitive task structure to maintain sensitivity of cognitive task to cognitive domain relationships. This approach allows robust and reproducible estimation of performance percentiles for Cambridge Neuropsychological Test Automated Battery (CANTAB) tasks, to further support diagnostic criteria and patient selection within the context of clinical trial recruitment. **Objectives:** The objectives of this study are firstly, to describe cognitive performance of a healthy population sample using CANTAB cognitive assessment battery across age, gender and education groups. Secondly, to utilise an approach that can capture appropriate cognitive task structures for robust estimation of performance percentiles. **Methods:** Data were collected using a web-based cognitive assessment application between September 2017 and April 2018. Participants were recruited using Prolific (<https://www.prolific.ac/>), an online platform for advertising web-based studies. In order to take part, participants had to confirm that they were aged ≥ 18 years of age; a fluent English speaker; had not experienced a significant head injury (that resulted in a loss of consciousness); had not been diagnosed with a mental health condition that is uncontrolled (by medication or intervention) and which has a significant impact on daily life; had never been diagnosed with mild cognitive impairment or dementia. Participants were asked to provide basic demographic information including their

age, sex and highest level of education. They then completed a cognitive assessment, lasting approximately thirty minutes, consisting of a series of three CANTAB tasks. Participants were asked to perform all of the cognitive tests on their own, in a quiet room and to the best of their ability. They were instructed that they should not conduct these tests if they were feeling unusually stressed, tired, or unwell, or under the influence of alcohol or other substances. All subjects provided informed consent prior to their participation and were reimbursed for their time on completion of the study. All the data were pre-processed in a reproducible R (version 3.4.4) environment using version control (git version 2.15) in a standalone Docker Container (version 18.03). CANTAB test performance was modelled as a function of age using a Bayesian GLM. The Bayesian GLM was crucial as it allowed incorporation of prior information about age distribution. At the same time, the parameterisation of response distribution allowed the appropriate test structure to be taken into account. For example, certain cognitive tests rely heavily on error-count type response variables; thus, it is important to fit a zero-inflated distribution (e.g., error count). Taking this approach is even more relevant when a disease groups is compared to a healthy or normative sample. **Results:** In total, 728 participants were included in the study, 49% of whom were female and aged between 18 and 75 (mean 39, standard deviation 13). The six levels of education were collapsed into two categories of «high» vs. «low» educational performance. Performance on the episodic memory test CANTAB Paired Associates Learning (PAL) outcome measure Total Error Adjusted (PALTEA) is discussed here. This measure describes number of errors with an adjustment for the number of attempts and the level of difficulty completed. Exploratory data analysis showed four key demographic groups male-high education, male-low education, female-high education and female-low education have different profiles of performance with age. On PALTEA, both male and females with high education are characterised by lower number of errors compared to the low education levels, as expected, with the high educated females having the lowest number of errors. The rate of change with age for females is greater than for the males, with high educated females showing the fastest cognitive decline. These differences are captured across the percentile performance tables. **Conclusions:** This study demonstrates the use of reproducible and robust methods to describe normative cognitive performance on CANTAB computerised test battery across demographic groupings.

P47: PREDICTING THE COURSE OF ALZHEIMER'S. Samuel Iddi^{1,3}, Dan Li¹, Wesley K Thompson², Michael S. Rafii¹, Paul S. Aisen¹, and Michael C Donohue¹ ((1) *ATRI, University of Southern California, San Diego, CA, United States*; (2) *Department of Family Medicine and Public Health, University of California, San Diego, USA*; (3) *Department of Statistics, University of Ghana, Legon-Accra, Ghana*)

Background: To better understand and predict the course of Alzheimer's disease (AD) from the asymptomatic to dementia stage, it is critical to study the patterns of progression of multiple markers of AD. Prediction of future clinical diagnosis of an individual (CN, MCI, or dementia) is very challenging due to high individual-level variability on cognitive assessments and biomarkers; as well as subjectivity and high clinician-to-clinician variability in diagnosis. **Objectives:** In this study, we proposed a two-stage approach to modeling and predicting markers of

Figure 1

Weighted error score for each of the models' ability to predict continuous disease markers over time. Note that all models include baseline diagnosis as a covariate except the LTJMM, which might explain its inferior performance. Jointly modelling continuous outcomes yields better performance relative to separate independent models (IMM); and including both cognitive assessments and imaging markers seems to improve prediction

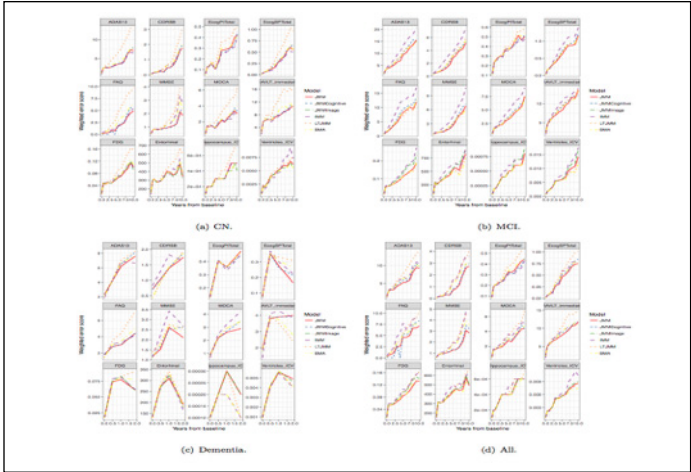

Abbreviations: CN; Control, MCI; Mild Cognitive Impairment, IMM; Independent Mixed-effects model, JMM; Joint Mixed-effects Model, LTJMM; Latent-time Joint Mixed-effects Model, BMA; Bayesian Model Averaging.

Figure 2

Diagnostic classification error for each model over time. Again, note that all models include baseline diagnosis as a covariate except the LTJMM, which might explain its inferior performance. Jointly modelling continuous outcomes seems yield better performance relative to separate independent models; and including both cognitive assessments and imaging markers seems to improve prediction

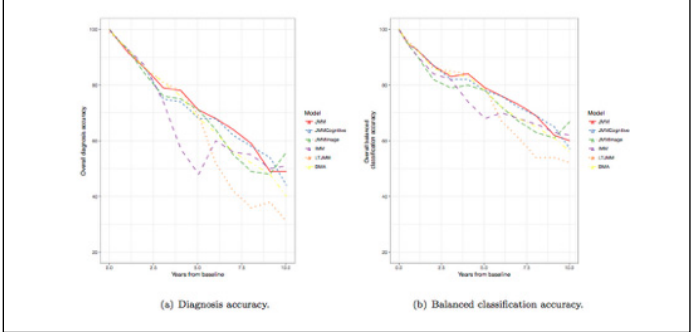

Abbreviations: CN; Control, MCI; Mild Cognitive Impairment, IMM; Independent Mixed-effects model, JMM; Joint Mixed-effects Model, LTJMM; Latent-time Joint Mixed-effects Model, BMA; Bayesian Model Averaging.

cognition, function, brain atrophy and metabolism, as well as diagnosis. We apply the approach to data from Alzheimer's Disease Neuroimaging Initiative (ADNI), and assess the ability to predict future cognitive performance, biomarkers and clinical diagnosis. **Methods:** In the first stage of the two-stage methodology, mixed-effects models are used to simultaneously model multiple markers over time. We considered different types of models, namely, separate or independent mixed effects models (IMMs), a joint mixed effects model (JMM), a latent-time joint mixed effects model (LTJMM) and a Bayesian model averaging of all the approaches. Furthermore, we consider cognitive and functional outcomes separately (JMMCog), from imaging markers (JMMImage) to demonstrate how each of these markers perform as predictors of change. In the second stage, random forest models were used to derive clinical diagnosis using markers predicted from the first stage model. We test the performance of the two-stage approach on data from the Alzheimer's disease neuroimaging initiative (ADNI). To evaluate the quality of continuous marker predictions, we use two metrics, the mean absolute error (MAE) and the weighted error score (WES). The latter takes into account confidence interval widths. Diagnostic classification error of the random forest algorithm is assessed by overall accuracy and balanced classification accuracy (BCA). The BCA accounts for imbalance in the proportions with each diagnosis. ADNI 1 and ADNI GO individuals made up the training dataset. In addition, baseline data from individuals in ADNI 2 were included in the training data to allow for estimation of their random effects for individual-specific predictions. The follow-up data from all ADNI 2 individuals was used as the test or validation dataset. Outcome measures included ADAS13-Cog, CRDSB, MMSE, MOCA, RAVLT, ECog, and FAQ, entorhinal cortical thickness, ventricular and hippocampal volume as measured by MRI, and regional metabolism as measured by FDG-PET. Baseline diagnosis, age, gender, and carriage of APOE e4 allele were included as covariates. **Results:** Results are summarized in Figure 1 and Figure 2. From Figure 1, we observe that predictions from the joint models perform quite well over two years, yielding lower mean absolute errors and weighted error scores. Not unexpectedly, the MAE and WES increase beyond two years. All models yield consistent performance over time with the JMM occasionally out-performing the other models. The IMM seems to perform worse for MCI and dementia subgroups. Also, the JMM with all markers seem to outperform domain-specific joint models. From Figure 2, we observe that the classification accuracy of disease status based on prediction from the joint mixed effects models outperforms those of independent models. Overall diagnostic accuracy above 80% was achieved over a period of 2.5 years. The results further indicate that, overall accuracy is improved when markers from all domains such as cognitive, functional, and imaging are used in the prediction algorithm as compare to the use of outcomes from a single marker domain. **Conclusions:** We have demonstrated the utility and limitations of the proposed two-stage modelling approach for predicting disease course in AD. The approach can be used to aid in clinical trial participant selection and study design, and might be useful for guiding clinical care.

P48: IMPAIRED DELAYED RECALL ON THE INTERNATIONAL SHOPPING LIST TASK PREDICTS AMYLOID POSITIVITY AND LONGITUDINAL DECLINE IN CDR-SB SCORES IN MCI. Sharon Rosenzweig-Lipson¹, Richard Mohs¹, Paul Maruff², Michela Gallagher^{1,3}, Arnold Bakker³ ((1) *Agenebio, Inc. 1101 E. 33rd Street, Suite C310, Baltimore, MD, USA*; (2) *Cogstate, Ltd., Melbourne, Victoria, Australia*; (3) *Johns Hopkins University, Baltimore, MD, USA*)

Background: Mild Cognitive Impairment (MCI) represents a broad category of cognitive impairments that may or may not progress to Alzheimer's dementia. Clinically, MCI is defined by impairment in performance on objective cognitive tests, most often memory, and acknowledgement by the individual or a close confidant that their cognition has declined previous time. Determining which patients will have abnormally high levels of amyloid (A β +) and will continue their cognitive decline is critical for identifying patients that more specifically have MCI due to Alzheimer's Disease (AD). The MCI due to AD condition is a critical phase in disease progression where early interventions have the potential to alter long-term outcome. The International Shopping List Task (ISLT) was developed specifically to assess verbal list learning and memory in people from different language and cultural backgrounds and can be administered repeatedly in patients with memory impairments (Thompson et al., 2011; Lim et al., 2012). Patients with MCI and AD demonstrate impairments on both total and delayed recall in the ISLT (Thompson et al., 2011; Lim et al., 2012) and this task is currently being used as part of enrollment criteria in clinical trials of MCI due to AD. The HOPE4MCI trial will assess the effects of AGB101 (low dose levetiracetam) in patients with MCI due to AD. As A PET imaging remains both invasive and expensive, optimal screening of memory impairment with methods sensitive to amyloid positivity and longitudinal decline are key to limiting the numbers of amyloid negative patients that are evaluated with PET imaging. To most effectively enroll patients in this trial with MCI due to AD, we evaluated the utility of the ISLT to predict A β + and subsequent cognitive/functional decline in patients with MCI. **Objectives:** The purpose of the present study was to evaluate the sensitivity of varying cut-scores on the ISLT immediate and delayed recall scores that would predict amyloid positivity and subsequent longitudinal cognitive/functional decline on the CDR sum of boxes score (CDR-SB). in patients with MCI. **Methods:** Data for 425 patients who met clinical criteria for MCI and who had undergone assessment with the ISLT, Clinical Dementia Rating Scale (CDR) and well as A PET imaging, as part of their enrollment in the inception and enrichment cohorts from the Australian Imaging Biomarkers and Lifestyle (AIBL) study were analyzed. Change over 18 months on the CDR-sum of boxes scores (CDR-SOB), as a measure of cognitive and functional decline, over 18 months was treated at the dependent variable. Cut-scores for abnormal performance on the ISLT were developed using age-stratified normative data and the rate of classification of AB+ and change in CDR-SOB was computed for each. **Results:** Cut-scores on the ISLT total recall of 1-1.5 standard deviations (SD) below the normative mean showed modest effect sizes for change of CDR-SB scores with high sensitivity to A β + but poor specificity to amyloid burden with high inclusion of amyloid negative cases. Cut-scores on the ISLT delayed recall of 1-1.25 SD below the normative mean showed similarly modest effect sizes for change of CDR-SB scores with high sensitivity but also poor specificity.

However, a cut-score of 1.5 SD below the normative mean specifically on the ISLT delayed recall showed a large effect size on change in the CDR-SB score over a period of 18 months with both high sensitivity and reasonable specificity for A β +. **Conclusions:** The ISLT is an objective cognitive assessment of memory function robust to variations in language and culture and sensitive to AD related memory impairment. Results from this study show that impairments on the delayed recall portion of the ISLT of less than, or equal to, 1.5 SD below the mean predicts longitudinal decline on the CDR-SB score and amyloid positivity with reasonable sensitivity and specificity. Together these results show the ISLT is a useful tool for initial selection of patients with MCI for further screening with amyloid imaging and enrollment in clinical trials. This research is supported by R01AG048349 to M.G and R56 AG055416 to R.M.

P49: MMSE SCREENING DATA QUALITY FOR ALZHEIMER'S DISEASE STUDIES ACROSS COUNTRIES. Jordan Mark Barbone¹, Todd M. Solomon^{1,2}, H. Todd Feaster¹, Macarena Garcia-Valdecasas Colell³, David S. Miller¹ ((1) *Bracket, Wayne, PA, USA*; (2) *Boston University School of Medicine, Boston, MA, USA*; (3) *Bracket, Reading, UK*)

Background: In part to better generalize to a global population, Alzheimer's disease (AD) clinical trials are becoming increasing inclusive of countries around the world. Given this evolving geographic expansion, identifying regions and countries that are able to enroll appropriate subjects and provide high quality outcome data continues to be paramount. This analysis included raters from several multinational phase 2 and 3 AD clinical trials. All studies employed an enhanced electronic version of the Mini-Mental State Exam (eMMSE). We evaluated both administration and scoring errors at both Screen and Baseline visits per country. The use of Electronic Clinical Outcome Assessments (eCOA) with internal scale logic and automatic scoring algorithms has been shown to significantly reduce error rates when compared to both paper and non-enhanced eCOA versions of the scales without compromising clinical validity. The addition of audio review of scale assessments has been shown to reveal errors otherwise virtually impossible to identify through review of the scale data alone. **Objective:** To determine differences in error rates in the administration and scoring of the MMSE across countries who participated in multiple AD clinical trials. **Methods:** Data from 12,206 visits from 43 countries across four multi-national phase 2 and 3 AD clinical trials which utilized an enhanced electronic Clinical-Reported Outcome (eClinRO) version of the MMSE with Bracket's, Rater StationSM tool were evaluated. In all studies, raters were qualified and provided scoring and administration training on the eMMSE and an active study surveillance program for data quality was implemented which included monitoring at the item level data. Audio recordings of scale administration were reviewed in half of these studies. As all Screening and Baseline eMMSE data were reviewed across all studies, error rates from these visits were calculated by subtest and type (i.e., scoring and/or administration). Countries were included in the analysis if they performed a minimum of 30 assessments for each visit. **Results:** A total of 24 countries with 11,168 eMMSE assessments met the criteria for evaluation of scoring errors. Across all programs, the overall error rate in scoring was 9.00%. Of these, the country with the highest scoring error rates was Israel with 29.41% (of 34 visits) and the country with the lowest was Turkey with 1.08% (of 93

visits). As not all studies utilized audio assessment, a total of 15 countries and 5,228 eMMSE assessments were reviewed for administration deviations. Across all programs, the overall error rate of 8.82%. Of these, the highest administration deviation rate was 16.17% (of 167 visits) found in Poland and the lowest was 1.27% (of 79 visits) found in Serbia. **Conclusions:** Prior research has demonstrated the benefits of utilizing enhanced electronic outcome measures combined with an in-study surveillance program to decrease rater error over the course of AD clinical trials. The current analysis indicates there can be substantial differences in eMMSE scale performance across countries. This variability, if not addressed, has the potential to impact data quality and lead to inappropriate enrollment of subjects in a clinical trial. Our analysis sample was limited in some regards to unbalanced number of sites, raters, and enrolled subjects per country. Error rates may be driven by early visits – or a handful of raters – but errors were remediated and reduced as the studies progressed. Thus while we do not immediately endorse changes in site selection simply based on these country findings we will continue to explore other methods in which to derive meaningful metrics for site selection. Continuing to identify raters and sites that provide high data quality remains critical to the success of AD clinical trials.

P50: AFFECTIVE VARIABILITY PREDICTS COGNITIVE FLUCTUATION AND DECLINE IN OLDER ADULTS. Edward Zamrini¹, Michael Malek-Ahmadi², Kathy O'Connor¹, Sharon Schofield¹ (1) Banner Sun Health Research Institute, Sun City, USA; (2) Banner Alzheimer's Institute, Phoenix, USA)

Introduction: Previous research has shown that the presence of affective symptoms associated with depression and anxiety can have a detrimental impact on cognitive function in cognitively unimpaired (CU) older adults. Many studies reporting this association are cross-sectional and have not investigated whether affective changes correlate with cognitive changes over time. **Objective:** The objective of this study was to determine whether intraindividual variability of self-reported affective symptoms is associated with year-to-year cognitive fluctuations and cognitive decline. **Methods:** Data from 639 older adult participants in the Longevity Study were used for this analysis. Subjects were assessed on an annual basis and did not have clinically significant cognitive or functional impairment. Subjects ranged in age from 54 to 102 with 71% of the sample being female. Intrasubject standard deviation (ISD) was used to quantify year-to-year variability and best linear unbiased predictor (BLUP) values were used as a measure of intraindividual linear change in cognition. The Montreal Cognitive Assessment (MoCA) was used as the cognitive outcome variable while the Centers for Epidemiologic Studies-Depression (CESD), Penn State Worry Questionnaire (PSWQ), and the perceived stress scale (PSS) were used to measure self-reported affective symptoms at each visit. The ISD for each of the affective scales was used as the predictor variable. Robust generalized linear models that adjusted for baseline age, gender, and education were used to analyze the data. **Results:** ISDs for all of the affective measures were positively associated with year-to-year variability on the MoCA (CESD: $\beta = 0.05$, 95% CI (0.007, 0.10), $p = 0.02$; PSWQ: $\beta = 0.07$, 95% CI (0.02, 0.13), $p = 0.01$; PSS: $\beta = 0.08$, 95% CI (0.01, 0.04), $p = 0.01$). ISDs for the affective measures were inversely associated with MoCA linear decline (CESD: $\beta = -0.06$, 95% CI (-0.10, -0.01),

$p = 0.02$; PSWQ: $\beta = -0.10$, 95% CI (-0.16, -0.05), $p < 0.001$; PSS: $\beta = -0.15$, 95% CI (-0.22, -0.10), $p < 0.001$). **Conclusions:** These results show that affective variability is associated with greater year-to-year MoCA performance variability and with greater linear decline on the MoCA. Given that both depressive and anxiety symptoms are known to negatively impact cognitive function, these results provide additional evidence supporting this relationship in a longitudinal context. In addition, the use of intraindividual measures is novel and may provide clinicians with a better understanding of how affective symptoms impact cognition. Given that affective symptoms can fluctuate greatly over time, understanding their subsequent impact on cognition is important for observational studies of aging and for clinical trial efficacy analyses.

P51: VALIDATION OF THE GERIATRIC DEPRESSION SCALE IN THE ELDERLY KOREAN WITH ALZHEIMER'S DISEASE. Moon Ho PARK, Do-Young Kwon (Department of Neurology, Korea University Ansan Hospital, Ansan, South Korea)

Background: Backgrounds: The Geriatric Depression Scale has been shown to be an effective screening test for depression in selected geriatric populations. However, it has not been evaluated as a screening test for depression among the elderly Korean with Alzheimer's disease. **Objectives:** This study aimed to evaluate the validity of Geriatric Depression Scale (GDpS) in the community-dwelling elderly cohort. **Methods:** The Korean version of GDpS was administered to 774 subjects with Alzheimer's disease, older than 60 years. The GDpS was measured and compared with the diagnosis of DSM-IV depression. The optimal cut-off point evaluation and ROC curve analysis were done to investigate the screening validity of the GDpS. **Results:** We suggest the optimal cut-off point for mild depression was 10 and that point for moderate depression was 22. **Conclusions:** The Korean version of the GDpS is an appropriate screening tool for geriatric depression, and a scores of 10 and 22 are the optimal cut-off for the elderly Korean with Alzheimer's disease. Screening for depression in the elderly population using the GDpS would be valuable when medically ill patients show depressive symptoms in a primary health care setting.

P52: CAN TMT-BLACK AND WHITE PREDICT THE WHITE MATTER HYPERINTENSITY OF MRI IN THE COMMUNITY BASED ELDERLY? Young Chul Youn

Table 1

White matter hyperintensity volume and performance of TMT-B&W in participants with Fazekas grade 0-3

WMH Fazekas grade	N	WMHV/ICV*	TOTAL-A**	MISS-A†	TOTAL-B	MISS-B
Grade 0	32	1.588 ± 1.050	71.26 ± 30.73	0.6 ± 0.9	178.30 ± 113.62	3.6 ± 3.8
Grade 1	38	2.055 ± 0.883	82.29 ± 40.23	1.0 ± 1.4	185.65 ± 109.67	5.2 ± 5.3
Grade 2	14	3.142 ± 1.423	107.28 ± 49.47	1.6 ± 1.8	224.78 ± 216.63	7.3 ± 7.9
Grade 3	5	11.83 ± 5.670	137.24 ± 57.89	4.0 ± 7.8	193.90 ± 66.25	1.8 ± 1.8
Total	89	2.853 ± 2.488	86.58 ± 47.70	1.1 ± 2.4	197.66 ± 130.68	5.2 ± 4.4

Values are presented by mean ± standard deviation. WMH: white matter hyperintensity; WMHV/ICV: white matter hyperintensity volume that is normalized with intracranial volume; TOTAL-A: time completing type A of TMT-B&W; TOTAL-B: time completing type B of TMT-B&W; MISS-A: Number of errors in doing type A of TMT-B&W; MISS-B: Number of errors in doing type B of TMT-B&W *ANOVA test, p-value <0.001, **p-value =0.011, †p-value =0.010

Figure 1

Boxplot presenting complete time doing type A of TMT-B&W depending on Fazekas' scale. Completing time doing type A of TMT-B&W (TOTAL-A) are increasing in the cognitive normal subject with higher Fazekas' scale from community

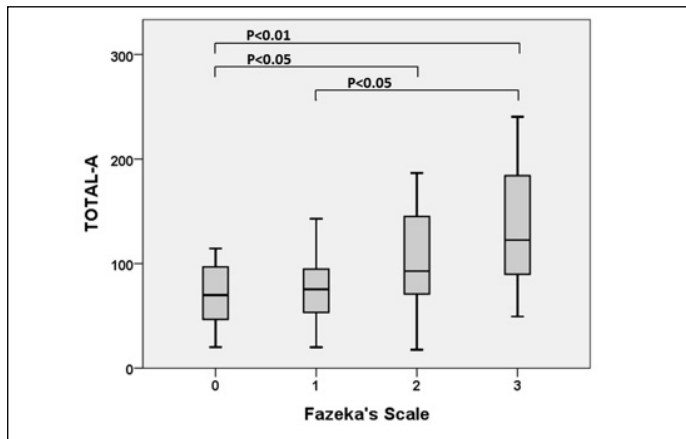

Table 2

The times and numbers of errors in performing TMT-B&W type A and B, and their composites (mean ± standard deviation)

	WMH (n=19)	WMH (n=70)	P-value
Age	70.8 ± 5.2 yrs	65.9 ± 4.4 yrs	<0.001
Sex (male/female)	4/15	33/37	0.005*
MMSE	27.5 ± 1.8	28.2 ± 1.3	0.058
WMH/ICV	5.37 ± 0.418	5.85 ± 0.092	0.005
Lt.Hipp/ICV	2.82 ± 0.202	2.91 ± 0.205	0.131
Rt.Hipp/ICV	2.40 ± 0.146	2.55 ± 0.141	0.131
TOTAL-A	115.38±6.81 sec	76.76±6.56 sec	0.015
TOTAL-B	254.25±108.14 sec	182.22±110.54 sec	0.032
SUB-AB	139.16±104.87 sec	103.46±98.33 sec	0.376
DIV-AB	2.55±1.07	2.42±1.19	0.573
MISS-A	2.971 ±0.0302 ±0.48	1000 ±0 ±1079.00	0.047
MISS-B	2.23±1.18	0.80±0.21	0.160
MISS-D	2.50±1.49	3.30±1.66	0.722

The WMH and hippocampal volumes differences and TMT-B&W performance variables between WMH(+) and WMH (-). The significance of each variables were tested with student t-test, but sex difference(*) between groups was evaluated with chi-square. yrs: years; sec: seconds; WMH: white matter hyperintensity; ICV: intracranial volume; Lt.Hipp/ICV: left hippocampal volume normalized with intracranial volume; Rt.Hipp/ICV: right hippocampal volume normalized with intracranial volume; TOTAL-A: time completing type A of TMT-B&W; TOTAL-B: time completing type B of TMT-B&W; SUB-AB: subtraction TOTAL-A from TOTAL-B; DIV-AB: division TOTAL-B by TOTAL-A; MISS-A: Number of errors in doing type A of TMT-B&W; MISS-B: Number of errors in doing type B of TMT-B&W

P55: CANTAB TESTS PREDICT CHANGE IN GLOBAL FUNCTIONING IN PATIENTS WITH AMNESTIC MILD COGNITIVE IMPAIRMENT. Elizabeth Baker¹, Peter Annas¹, Giovanni B. Frisoni^{2,19}, David Bartres-Faz³, Beatriz Bosch³, José Luis Molinuevo³, Mira Didic^{4,5}, Francesca De Anna^{4,5}, Lucilla Parnetti⁶, Nicola Salvadori⁶, Jens Wiltfang^{7,15}, Flavio Nobili⁸, Nicola Gartner⁸, Peter Schönknecht⁹, Pieter J. Visser¹⁰, Paolo M. Rossini¹¹, Paola Chioyenda¹¹, Pierre Payoux¹², Andrea Soricelli¹³, Marco Salvatore¹³, Magda Tsolaki¹⁴, Jill C. Richardson¹⁶, Régis Bordet¹⁷, Olivier Blin¹⁸, Gianluigi Forloni²⁰ on behalf of the PharmaCog Consortium ((1) *Cambridge Cognition Ltd, Bottisham, Cambridge, UK*; (2) *Laboratory of Alzheimer's Neuroimaging & Epidemiology, Saint John of God Clinical Research Centre, Brescia, Italy*; (3) *Department of Psychiatry and Clinical Psychobiology, Faculty of Medicine, University of Barcelona and Institut d'Investigacions Biomediques August Pi i Sunyer (IDIBAPS), Barcelona, Catalunya, Spain*; (4) *Aix-Marseille Universite, INSERM, France*; (5) *Service de Neurologie et Neuropsychologie, APHM Hôpital Timone Adultes, Marseille, France*; (6) *Clinica Neurologica, Università di Perugia, Ospedale Santa Maria della Misericordia,*

Perugia, Italy; (7) *Department of Psychiatry and Psychotherapy, Faculty of Medicine, LVR-Hospital Essen, University of Duisburg-Essen, Essen, Germany*; (8) *Clinical Neurology, Department of Neurosciences, Rehabilitation, Ophthalmology and Maternal-Fetal Medicine, University of Genoa, Genoa, Italy*; (9) *Department of Psychiatry and Psychotherapy, University of Leipzig, Leipzig, Germany*; (10) *Department of Neurology, Alzheimer Centre, VU Medical Centre, Amsterdam, the Netherlands*; (11) *Department of Gerontology, Neurosciences & Orthopedics, Catholic University, Rome, Italy*; (12) *ToNIC, Toulouse NeuroImaging Center, Université de Toulouse, Inserm, UPS, France*; (13) *SDN Istituto di Ricerca Diagnostica e Nucleare, Naples, Italy*; (14) *Third Neurologic Clinic, Medical School, G. Papanikolaou Hospital, Aristotle University of Thessaloniki, Thessaloniki, Greece*; (15) *Department of Psychiatry and Psychotherapy, University Medical Center, Georg-August-University, Goettingen, Germany*; (16) *Neurosciences Therapeutic Area, GlaxoSmithKline R&D, Stevenage, UK*; (17) *University of Lille, Inserm, CHU Lille, U1171 – Degenerative and Vascular Cognitive Disorders, Lille, France*; (18) *Aix-Marseille University, UMR Inserm 1106, Institute Neurosciences Sytemes, Marseille, France*; (19) *Memory Clinic and LANVIE – Laboratory of Neuroimaging of Aging, University Hospitals and University of Geneva, Geneva, Switzerland*; (20) *Department of Neuroscience, Mario Negri Institute for Pharmacological Research, Milan, Italy*)

Background: Changes in episodic memory is present very early in the development of Alzheimer's disease. In fact, one study has shown that episodic memory deficits are present more than 6 years prior to diagnosis. A cognitive test of episodic memory is the Cambridge Neuropsychological Test Automated Battery (CANTAB) Paired Associate Learning (PAL) task. This test has in a number of clinical studies shown to be sensitive to different stages of disease progression, to drug effects and to different relevant AD biomarkers. **Objectives:** Patients with amnesic mild cognitive impairment (aMCI) were monitored for changes in functional ability alongside episodic memory using Functional Activities Questionnaire (FAQ). The objective of the present analysis was to explore the relationship between CANTAB tests PAL, CANTAB Spatial Working Memory (SWM) and change over time in activities of daily living. **Methods:** The study sample comprised 147 aMCI patients, aged 55 to 90 years, who were enrolled in 13 European memory clinics Amsterdam (n = 4); Barcelona (n = 13); Brescia (n = 29); Essen (n = 1); Genoa (n = 16); Leipzig (n = 8); Lille (n = 2); Marseille (n = 8); Naples (n = 6); Perugia (n = 28); Rome (n = 6); Thessaloniki (n = 19) and Toulouse (n = 7). The individuals has subjective memory complaints, a Mini-mental State Examination score ≥24 and Clinical Dementia Rating score of 0.5 and were free of other neurological, systemic or psychiatric illness including depression (≤5 on the 15-item Geriatric Depression Scale and no usage of antidepressant drugs). Informed written consent was obtained from all patients and the study was reviewed and approved by the local ethics committees. Cerebrospinal Fluid (CSF) samples were collected and levels of Amyloid-β 42, phosphorylated tau 181 (p-tau) and tau proteins were measured. The FAQ and the CANTAB cognitive test battery were administered throughout study follow-up. For the analysis, prediction models were developed to classify individuals by change in FAQ. Participant demographics and performance on CANTAB tests were split into training, validation and test set fractions. For model building, the training and validation sets were used. Whilst the test set was used for reporting of performance. The models were trained using a five-fold cross

validation scheme. **Results:** CANTAB PAL in combination with age, gender and CANTAB SWM tasks were able to predict those subjects with the greatest decline in FAQ with excellent performance (Accuracy 0.83, Specificity 0.75 and Sensitivity 1.0). Whilst the group with greatest decline in FAQ was enriched for individuals with both low levels of CSF amyloid and AD diagnosis at last follow-up, 31% of individuals within the non-declining group had low CSF amyloid levels, reflecting those that were still MCI at last follow-up. Taken together these results suggests that scores on CANTAB PAL and SWM correlate with future functional deterioration, providing useful screening information for recruitment into Alzheimer's disease clinical trials. **Discussion:** Tests of episodic and working memory, which are sensitive to early biomarker changes in Alzheimer's disease, are also able to predict those who undergo functional decline in a sample of aMCI individuals. This provides encouraging evidence to support the use of these tests to identify those most at risk of progression to Alzheimer's disease.

P63: VALIDATING SIMULATED COGNITION TRAJECTORIES BASED ON ADNI AGAINST TRAJECTORIES FROM THE NATIONAL ALZHEIMER'S COORDINATING CENTER (NACC) DATASET. Ali Tafazzoli¹, Josh Weng², Kelly Sutton³, Michal Litkiewicz³, Ameya Chavan¹, Mira Krotneva⁴, Anuraag Kansal¹ ((1) Evidera, Bethesda, MD, USA; (2) Evidera, Waltham, MA, USA; (3) Evidera, London, UK; (4) Evidera, Montreal, Canada)

Background: Simulation offers a potential mechanism for extending the findings of AD clinical trials over longer times and to broader populations that those considered in the clinical trial itself. It is necessary, however, to understand the range of settings for which simulation results may have validity. An important test of that range is external validation – the comparison of the simulation outcomes with observed clinical data that were not used in its construction. **Objectives:** The aim of this study was to compare trajectories of cognitive change from a disease simulation built using ADNI data with observed trajectories from the NACC dataset. **Methods:** Simulation outcomes from the Alzheimer's Disease Archimedes Condition-Event (AD ACE) simulator were compared to observed trajectories from NACC. Observed trajectories were based on the set of all NACC patients with at least three visits (including baseline visit) with a baseline cognitive status of: 1) normal cognition or subjective memory complaint (CN-SMC), 2) mild cognitive impairment (MCI), or 3) mild AD. Population average trajectories were computed for each subgroup independently, adjusting each visit timing to the nearest six month timepoint. No imputation was performed for missing data, so the population average trajectories included different sets of patients at each time point. The AD ACE is a disease simulator that predicts the progression of AD in terms of multiple interacting trajectories of key biomarkers and major cognition, behavior, function, and dependence scales. The core disease progression in the AD ACE uses predictive equations derived from statistical analyses of the ADNI data for rate of change in CSF t-tau, FDG-PET, hippocampal volume, amyloid PET, MMSE, CDR-SB, ADAS-Cog, and NPI (Kansal et al., 2018). Patients in the AD ACE were split into three subgroups based on the range of cognition scores for those groups in the NACC data. The simulations sampled 500 patients from each subgroup in AD ACE and simulated each patient over a 10-year time

horizon outputting all measures of disease progression each six months. No modifications or fitting was performed in the disease simulation for these analyses. **Results:** A total of 385 patients were identified in NACC for inclusion (40 CN-SMC, 125 MCI, 220 mild AD). The filtered subgroups in the AD ACE were well-matched with the NACC subgroups in terms of mean age and cognitive levels (CDR-SB and MMSE) at baseline (year 0 in Figures 1 and 2). The simulated trajectories for CDRSB and MMSE agree well with the mean trajectories from NACC in all subgroups (Figures 1 and 2). The observed trajectories show greater variance at late times as patient counts decrease and the population of patients at each time point becomes less consistent. **Conclusions:** A disease simulator developed using data from ADNI was able to reproduce cognitive decline in three subgroups of the NACC dataset, supporting the external validity of the disease equations in incorporates. [1] Kansal, AR et al. Alzheimer's & Dementia: Translational Research & Clinical Interventions 4 (2018) 76-88.

Figure 1

Mean CDRSB trajectories for NACC vs. AD ACE for different AD disease severity levels

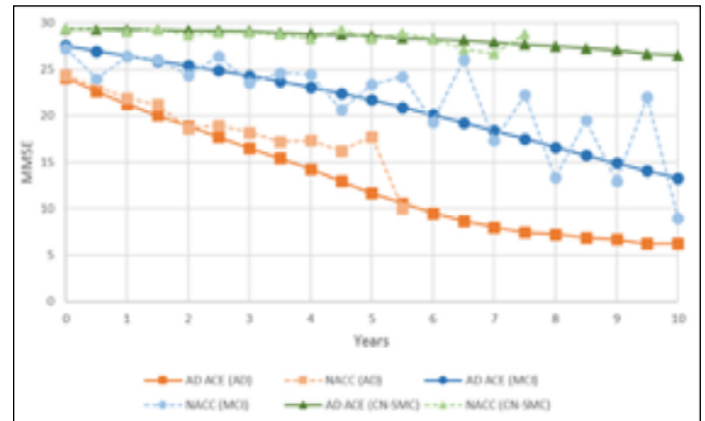
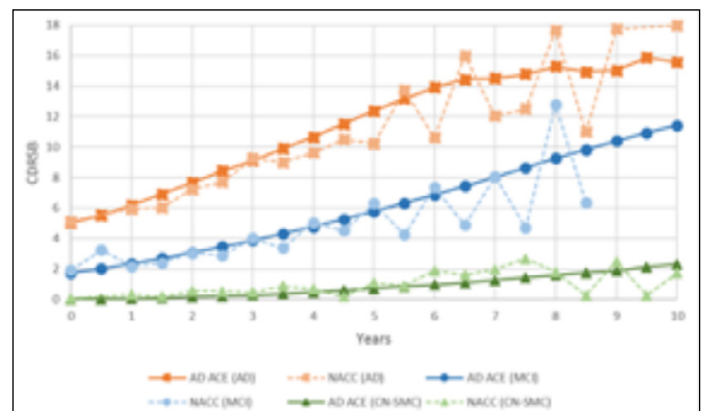

Figure 2

Mean MMSE trajectories for NACC vs. AD ACE for different AD disease severity levels



CN, cognitively normal; SMC, significant memory concern; MCI, mild cognitive impairment; AD, Alzheimer's disease; MMSE, mini-mental state examination; CDRSB, clinical dementia rating scale-sum of boxes; NACC, national Alzheimer's coordinating center; AD ACE, Alzheimer's disease Archimedes condition-event

P68: RECRUITMENT USING THE DCTCLOCK™. Daniel Lawler, Stephen Thein (*Pacific Research Network Inc., San Diego, CA, USA*)

Background: Patient recruitment has become the largest single reason cited as a delay in on-time clinical trial completion. Experience has shown that denial of memory impairment adds significantly to the problem. When a patient must return to the clinic for a skilled assessment instead of doing a quick on the spot assessment, attrition is inevitable. One solution identified was to “cast a wider net” method of quickly identifying potentially memory-impaired people using a tool which does not require special skills. It was theorized that if an accurate and fast, non-confrontational cognitive assessment method could be utilized, fewer patients would be lost to attrition. **Objective:** The DCTclock™ test from Digital Cognition Technologies is FDA cleared for the assessment of impairment in cognition via a simple clock drawing process. Each person serves as their own control, first drawing a clock from memory and then copying that same clock from a drawing using a digitizing ballpoint pen that samples the drawing process 75 times a second. This non-confrontational test requires just minutes to complete, with the added benefit of needing only simple directions for administration. Scoring is done immediately and automatically via a computerized algorithm that yields a numerical score of 0 to 100; the lower the score the greater the impairment. We classify those with scores under 55 as suggestive of some memory changes and invite them to our clinic for further evaluation. **Methods:** Initially three advertisements were created for placement in our newspaper, identical in size, placement and script; the only differences were minor graphics and the addition of a sentence inviting people to “draw a figure for a memory analysis associated with aging.” In this manner it was hoped that a difference in ad response rates might speak to the value of conducting a cognitive assessment via the DCTclock. Unfortunately, the ad response rate was unchanged from historical ad response rates. It was then theorized that using the DCTclock in a social setting, such as a community memory event, might demonstrate its usefulness but it was quickly determined that too many barriers existed to simply evaluate the effectiveness of the DCTclock as a sole determinate in identifying those with some memory impairment. Several consents were required, which were time consuming and tended to discourage people. This is contrary to what this assessment was intended to do—to provide a quick and non-intrusive way of ascertaining cognitive function. Our research protocol was amended and a shorter, one-page consent was drafted which incorporated both the California Bill of Rights for Research Subjects, and the use of the DCTclock in researching memory. **Results:** Historical data will be used to examine the number of patients who attended a community event (“memory fair”, Alzheimer’s event, etc.), who then self-refer to our clinic for formal memory testing. This will be compared to those who attended an event where the DCTclock is used as the only cognitive screening device. The use of our combined HIPPA form allows us to identify and call patients later for follow up. This prevented patients from “conveniently forgetting” to return for initial assessment. Both groups will be adjusted so that they are similar in size. The two groups will then be analyzed to determine the total numbers of subjects actually consenting for further procedures specific to study entry. The net result of how many subjects actually enter trials will not be determined and is beyond the

scope and time allowance of this poster. The purpose of this study is not to look at success in numbers entering trials but in enlarging the recruitment pool of potential subjects for trials. **Conclusions:** Traditional recruiting methods do not appear to benefit from advertising a “special pen and technique” of assessing cognition. We learned that the need for multiple consent forms act as a barrier to recruitment. We hope to present data which show that similar memory events are “more productive” (produce greater numbers of perspective subjects) using the DCTclock than having people self-refer, at a later date, to the clinic for assessment. **Discussion:** Community events which have a preponderance of older people, are more likely to draw attendees with some memory impairments. The DCTclock is a non-threatening, simple and easy way to assess cognition. It requires no special training and can rapidly identify those with some cognitive impairment. Consents and similar “contracts” create barriers and reluctance. The use of the DCTclock normally does not require a consent. A HIPPA form, however, is required if one wants, at a later, time to contact subjects for follow up.

P70: STRATEGY OR SYMPTOM: SEMANTIC CLUSTERING AND RISK OF ALZHEIMER’S DISEASE. Jamie Ford, Bang Zheng, Barbara Hurtado, M.A, CPsychol, Chi Udeh-Momoh, Geraint Price (*Imperial College London, UK*)

Background: In clinical trials for Alzheimer’s disease (AD), List Learning Tasks (LLTs) are commonly used as a cognitive outcome to evaluate changes in episodic memory. Performance on LLTs can be enhanced by the use of mnemonic strategies to aid word consolidation and recall. Consequently, they are often proposed as a means of compensating for memory decline. One example of such a strategy is the grouping of words of similar meaning - a process called Semantic Clustering (SC). However, the use of mnemonic strategies is itself compromised in MCI and dementia due to AD, thus undermining their beneficial value in clinical populations. In earlier stages of AD (prior to the development of MCI), the effectiveness of mnemonic strategies is unknown. One possibility is that in preclinical or at-risk states for AD, the use of such strategies may be preserved and could help to maintain memory performance despite underlying pathology. Another possibility is that strategy use may decline early in the course of AD, thus contributing to (rather than protecting from) a decline in episodic memory. This study aimed to investigate these two contrasting aspects of mnemonic strategy use, with specific reference to the use of SC in LLTs amongst cognitively healthy individuals at risk of AD. **Methods:** The CHARLOTTE PRO Main Study recruited cognitively healthy individuals aged 60-85, some of whom were at increased risk of AD due to their genotype (APOE ε4 carriers). Participants underwent a wide range of biomedical, lifestyle and cognitive assessments. Previous analyses of this sample (Udeh-Momoh et al., 2017) found subtle differences in cognitive performance between APOE sub-groups. The present study analysed data from 696 participants’ performance on the Memory and Executive Function modules of the Neuropsychological Assessment Battery (NAB). The Executive Function module includes a direct measure of the underlying ability to form semantic groupings (the Categories task, CAT). The Memory module includes a LLT in which the participant’s usage of SC is quantified. A semantic cluster is defined by the NAB as a group of two or more words of similar meaning being verbally recalled in succession. These are recorded and participants

are scored one point every time a semantic cluster is formed. Analyses investigated relationships between executive function (CAT), strategy use (SC), and performance in an episodic memory test (LLT), in relation to APOE ϵ 4 genotype status, with adjustments for age, gender and educational level. **Results:** CAT scores were not significantly lower amongst APOE ϵ 4 carriers, suggesting that this aspect of executive function has been preserved in the at-risk group. There were significant correlations (ranging from 0.63 to 0.71) between SC use and List Learning scores. In regression analyses, executive function (as measured by the CAT task) significantly predicted List Learning performance (crude regression coefficient = 0.47; $p < 0.001$). After controlling for SC use, the association was weakened (regression coefficient = 0.25; $p < 0.001$). Thus SC use appears to partially mediate the relationship between executive function and LLT performance. **Conclusion:** Our results demonstrate a significant relationship between executive function and list learning performance. This relationship was partially mediated by the use of semantic clustering. Better executive function is associated with greater use of mnemonic strategies and, in turn, with better performance on memory tasks. Furthermore, APOE ϵ 4 carriers did not demonstrate deficits in executive function in comparison with non-carriers. It is therefore likely that at the preclinical stage, these participants retain the ability to make use of mnemonic strategies in memory tasks. A moderation analysis (to be presented at the conference) will test the “cognitive reserve” hypothesis that strategy use confers preferential protection against episodic memory deficits in APOE ϵ 4 carriers. This possibility (that underlying memory decline may be masked by preserved executive function and compensatory strategy use) is of relevance to the value and interpretation of LLTs as outcome measures in clinical trials. Key words: Alzheimer’s disease, Semantic Clustering, memory, list learning.

P72: TAU IS ASSOCIATED WITH LONGITUDINAL MEMORY DECLINE IN HEALTHY SUBJECTS: THE NEED FOR AN EARLY DETECTION OF SUBTLE COGNITIVE CHANGES. Adrià Tort-Merino¹, Jaume Olives¹, María León¹, Claudia Peñaloza², Natalia Valech¹, Petra Grönholm-Nyman³, Pablo Martínez-Lage⁴, Juan Fortea^{5,6}, José Luis Molinuevo^{1,7}, Raquel Sánchez-Valle^{1,8}, Matti Laine¹, Antoni Rodríguez-Fornells^{2,9,10} Lorena Rami^{1,8} (1) *Alzheimer’s Disease and Other Cognitive Disorders Unit, Neurology Service, Hospital Clínic, Barcelona, Spain;* (2) *Cognition and Brain Plasticity Group, Bellvitge Biomedical Research Institute- IDIBELL, L’Hospitalet de Llobregat, Barcelona, Spain;* (3) *Department of Psychology, Åbo Akademi University, FIN-20500 Turku, Finland;* (4) *Neurología, Fundación CITA-Alzheimer Fundazioa, Centro de Investigación y Terapias Avanzadas, San Sebastián, Guipúzcoa, España;* (5) *Memory Unit, Department of Neurology, Hospital de la Santa Creu i Sant Pau and Institute of Biomedical Research, Barcelona, Spain;* (6) *Centro de Investigación Biomédica en Red de Enfermedades Neurodegenerativas Neurodegenerativas, CIBERNED, Spain;* (7) *BarcelonaBeta Brain Research Center, Pasqual Maragall Foundation, Barcelona, Spain;* (8) *August Pi i Sunyer Biomedical Research Institute (IDIBAPS), Barcelona, Spain;* (9) *Catalan Institution for Research and Advanced Studies (ICREA), Barcelona, Spain;* (10) *Department of Cognition, Development and Education Psychology, Campus Bellvitge, University of Barcelona, L’Hospitalet de Llobregat, Barcelona, Spain*

Background: Since the usefulness of standard neuropsychological tests for detecting subtle cognitive changes

in cognitively healthy individuals has been questioned, there is an increasing need to develop more sensitive cognitive measures in order to test new disease modifying pharmacological and non-pharmacological strategies in at-risk subjects. Using previous research on the neural mechanisms involved in language learning and memory, our working group recently evaluated a highly demanding learning and memory test called the Ancient Farming Equipment Test (AFE-T). This task engages the declarative memory system in order to learn to associate unfamiliar names (new labels or words) to completely new objects. In a recent study, we employed the AFE-T to detect subtle cognitive difficulties in preclinical AD subjects. The AFE-T was found to be a promising tool for characterizing the cognitive profile of preclinical AD, being sensitive enough to detect initial learning difficulties in at-risk population. Here, our aim was to examine and follow up a sample of cognitively healthy subjects with a normal pattern of CSF biomarkers in order to detect demographical and biological variables related to the longitudinal decline in memory function. Employing the sensitive AFE-T cognitive measure, we specifically wanted to investigate if a biomarker related to neurodegeneration (i.e., CSF tau) is associated with the longitudinal decline of learning and memory function in normal aging; **Methods:** Thirty-two cognitively and biologically normal (CBN) subjects underwent MRI, neuropsychological assessment and the AFE-T at baseline and 18 months later. The AFE-T called for learning of two lists of new object/name pairs. List A was administered at the baseline assessment and list B at the 18-month follow-up. For both lists, the objects were 24 black-and-white images of ancient farming equipment. Each object was paired with a pseudoword, that is, a non-existing word that follows the phonotactic rules of Spanish. The object names consisted of 14 bisyllabic and 10 trisyllabic pseudowords that do not exist in the Spanish dictionary. Word lists were administered in two initial learning sessions that were performed on two consecutive days. Each learning session included a total of seven runs and took approximately 45 minutes and the range of scores was 0-24 per run. After the last run of the second learning day, an immediate cued recall (ICR) was administered. To explore the relationship between the memory performance and relevant factors, a linear model was set up. After main analyses, to further explore the effect of tau, we divided the present sample into two groups. Subjects were experimentally classified into CBN-Tau \downarrow and CBN-Tau \uparrow according to their CSF tau levels. Subjects with CSF tau levels below 228.64 pg/ml were classified as CBN-Tau \downarrow (n=16) and subjects with CSF tau above 228.64 pg/ml were included in the CBN-Tau \uparrow group (n=16). Follow-up between-group differences were analyzed using mixed-model ANCOVA controlling for age, years of education and CSF A β 42 levels with post-hoc Bonferroni corrections. **Results:** In the whole sample, age ranged between 53 and 78 years and educational level between 5 and 18 years. Female/male ratio was 62.5/37.5. Regarding the CSF biomarker levels, the mean CSF A β 42 was 824.1 (SD 210.9) pg/ml [557.5-1405.0], CSF tau was 228.6 (SD 72.3) pg/ml [83.5-364.2] and CSF ptau was 50.9 (SD 13.5) pg/ml [23.5-71.0]. Only 2 subjects (6.2%) were APOE ϵ 4 positive. Main linear model results showed an association between CSF tau levels and longitudinal memory decline measured with the AFE-T ($B = -0.18$; $p < 0.01$; Fig. 1) Further analyses showed no differences between CBN-Tau \downarrow and CBN-Tau \uparrow groups in age ($t(30) = 0.80$; $p = .428$), years of education ($t(30) = 0.09$; $p = .928$), cognitive reserve ($t(26) = -1.03$; $p = .312$), or CSF A β 42 levels ($t(30) = 2.04$; $p = .039$). There were

no significant differences between groups in terms of gender distribution ($\chi^2=0.35$; $p=.554$) or in APOE- $\epsilon 4$ allele frequency ($\chi^2=1.88$; $p=.170$). Significant differences were naturally enough found in CSF tau ($t(30)=9.32$; $p<0.01$) and CSF ptau ($t(30)=6.31$; $p<0.01$). Comparative analyses showed different longitudinal learning patterns between groups, indicating an accelerated memory decline in individuals with higher tau ($F(1,31)=8.37$; $p<0.01$; Fig. 2). **Conclusions:** Our findings provide evidence for biological markers linked to cognitive aging highlighting the role of tau, a marker of neurodegeneration, which can be related with longitudinal memory decline even in healthy subjects. The AFE-T was able to detect subtle cognitive changes which were otherwise undetected by the standard neuropsychological tests. The development of new cognitive measures is crucial to test new disease modifying pharmacological and non-pharmacological strategies in at-risk subjects.

Figure 1

Correlation in the whole sample between CSF tau levels and the ICR difference score of the AFE-T

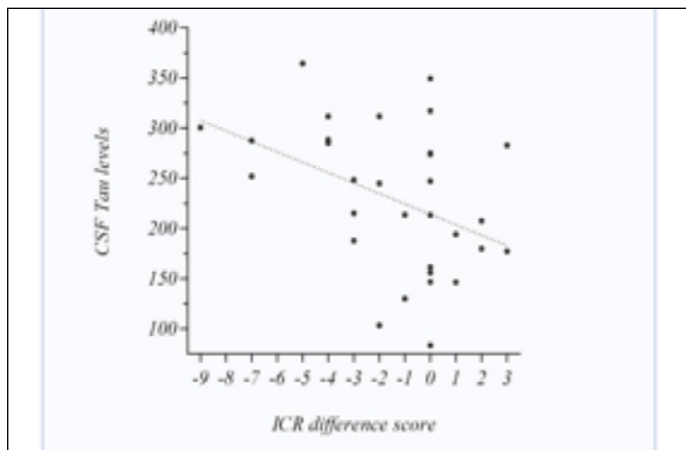

Key: ICR, immediate cued recall of the AFE-T (difference between baseline and follow-up scores)

Figure 2

Comparison of the AFE-T baseline and follow-up performance in the CBN-Tau \downarrow and CBN-Tau \uparrow groups

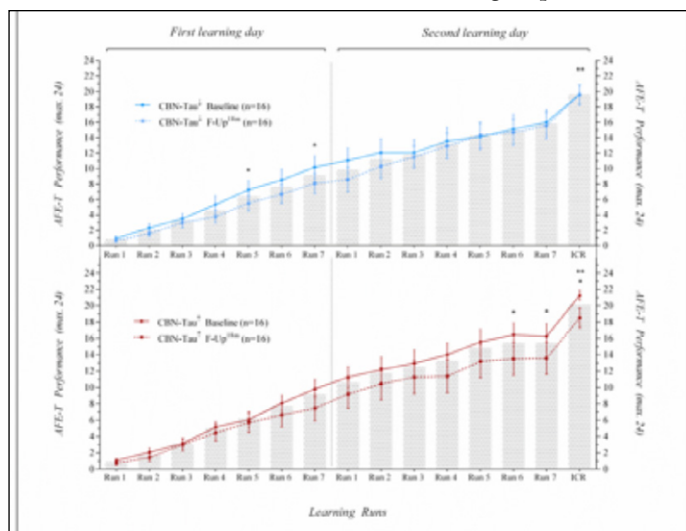

Key: CBN, Cognitively and Biologically Normal; ICR, immediate cued recall; * $p<0.01$ (within-group differences); ** $p<0.01$ (between-group difference)

P87: CLINICAL EFFECTS OF ORAL TRAMIPROSATE IN APOE4/4 HOMOZYGOTES WITH MILD ALZHEIMER'S DISEASE (AD): RESPONDER ANALYSES OF COGNITIVE AND FUNCTIONAL OUTCOMES. Alexandra S. Atkins¹, Anzalee Khan^{1,2}, Daniel Ulshen¹, John Harrison^{3,4}, Brenda L. Plassman⁵, Kathleen A. Welsh-Bohmer⁵, Richard S.E. Keefe^{1,6} ((1) *NeuroCog Trials, Durham, NC*; (2) *Nathan S. Kline Institute for Psychiatric Research, Orangeburg, NY*; (3) *Alzheimer Center, VUmc, Amsterdam, The Netherlands*; (4) *IoPPN, King's College, London, UK*; (5) *Duke University Bryan ADRC, Durham, NC*; (6) *Duke University Medical Center, Durham, NC*; (7) *Duke University Medical Center, Durham, NC*)

Background: Clinical drug trials in preclinical AD populations will require novel approaches to participant identification, screening, and enrollment. Cognitive screening instruments must be straightforward, sensitive to disease-specific pathology, and allow for the interpretation of findings over time relative to demographically age-matched normative samples. Well-designed assessments of visuospatial working memory may serve as fruitful screening measures. Specific impairments in visuospatial working memory related to hippocampal-dependent binding of stimulus features have been suggested as a potential early marker AD neuropathology. Prior work in this area has shown that subjects with mild cognitive impairment may not differ from healthy controls in basic working memory tasks, but tasks that require encoding and maintenance of combined object features, such as identity and location, demonstrate increased sensitivity. The specificity of these deficits suggest a potential relationship between task performance and reduced integrity of the hippocampal, perirhinal and entorhinal cortices which are affected early in AD pathology. We describe results of a recent study utilizing a novel tablet-based visuospatial working memory (VSWM) task to examine differences between healthy older adults with and without subjective cognitive decline (SCD). **Methods:** Participants included 168 healthy young adults (YA, <55 years), 275 healthy older adults (OA, ≥ 55 years), and 60 individuals with subjective cognitive decline (SCD). Participants with SCD were categorized as such based on total scores of ≥ 4 on the Mail-In Function Cognitive Screening Instrument (MCSFI). Participants completed the VSWM task along additional assessments of cognition and function at two study visits approximately 1 week apart. In the VSWM task, participants encoded object-location pairs by tapping items as they appeared in sequence on a grid. Next, a central probe appeared and participants tapped the location where the object first appeared. A sequence was considered correct only when each item in the sequence was located correctly. Sequence length and grid size increased throughout the task. In the Sequential portion of the task, memoranda were probed in the order or encoding. In the Random portion of the task, memoranda were probed in random order. The VSWM total score was calculated as the sum of the total sequences correct in the Sequential and Random portions of the task. Group differences in VSWM total score were assessed, as were differences in Sequential and Random sub-scores. P-values for post-hoc pairwise comparisons were corrected using the Bonferroni procedure. Intraclass correlation coefficients (ICC, two-way random effects model for absolute agreement) were computed to assess test-retest reliability. **Results:** Statistically significant differences were demonstrated among the three groups for the VSWM total score as well as the Sequential and Random subscores ($p<.001$ for all). Bonferroni

post hoc tests showed a significant differences between the YA group, the OA group and the SCD group, with the OA group performing significantly worse than the YA group and the SCD group performing significantly worse than the OA group on three measures ($p < 0.001$ for all comparisons). The SCD group also performed significantly worse than the OA group on standard objective cognitive tests ($p < .001$ for all), suggesting concordance between subjective and objective cognitive decline. On the MoCA, the SCD group performed 0.92 SDs (2.67 points) lower than the OA group. On the TMT-B, the SCD group took an average of 37.62 seconds (0.69 SDs) longer than the OA group to complete the task. Test-retest reliability of the VSWM test was strong. ICCs for VSWM total scores were .82 for YAs, .78 for OAs and .81 for participants with SCD. **Conclusions:** A brief assessment of visuospatial working memory is sensitive to differences between healthy older adults with and without subjective cognitive decline, suggesting the instrument may be sensitive to the earliest stages of cognitive impairment. The specificity of observed declines in hippocampal-dependent tasks such as this offer a link to underlying AD pathology not provided by more global cognitive screening instruments.

P88: SEVERE COGNITIVE IMPAIRMENT IN OLDER ADULT HEART FAILURE PATIENTS: PRELIMINARY FINDINGS FROM THE DEUS EX MACHINA STUDY. Emília Moreira¹, Sónia Martins^{1,2}, Luís Filipe Azevedo^{1,3}, José SilvaCardoso^{1,4,5}, Lia Fernandes^{1,2,6} ((1) Center for Health Technology and Services Research/CINTESIS, Faculty of Medicine, University of Porto - Portugal; (2) Department of Clinical Neurosciences and Mental Health, Faculty of Medicine, University of Porto - Portugal; (3) Department of Community Medicine, Information and Health Decision Sciences/MEDCIDS, Faculty of Medicine, University of Porto - Portugal; (4) Department of Medicine, Faculty of Medicine, University of Porto - Portugal; (5) Department of Cardiology S. João Hospital Center, Porto - Portugal; (6) Clinic of Psychiatry and Mental Health, S. João Hospital Center, Porto - Portugal)

Background: Cognitive impairment (CI) is common in Heart Failure (HF) patients, ranging from 25% to 80%, depending on HF severity and cognitive assessment procedures. Several pathophysiological processes connecting HF and CI have been explored, such as brain hypoperfusion and inflammation processes. Overall importance of cardiovascular risk factors on dementia onset are well established, but evidence from longitudinal studies relating HF to dementia show some inconsistencies, mostly due to methodological differences and because population studies are frequently too small to detect clinically relevant associations. HF patients also show great heterogeneity regarding cognitive function. In order to identify different HF patient groups and their prognosis, more studies are needed. **Objectives:** To determine the presence of severe cognitive impairment in HF outpatients aged ≥ 60 years old and to analyse the associated factors. **Methods:** Participants were randomly selected from the patient list of an HF outpatient clinic in a University Hospital. Sociodemographic data, Left Ventricular Ejection Fraction (LVEF) and New York Heart Association (NYHA) class were registered. Cognitive function was assessed using the Montreal Cognitive Assessment Test (MoCA). Mild and severe cognitive impairment were defined as MoCA score < 22 and < 17 , respectively. A predefined checklist was used to register the observation of the participants' behaviours during the cognitive assessment procedure.

Instrumental Activities of Daily Living (IADL) were assessed with the Lawton & Brody Scale. Associations with CI were explored using univariate analysis and a logistic regression model, with CI as the dependent variable, entered as covariates age, education, LVEF and NYHA. **Results:** A total of 45 HF patients were included, with a mean age of 68 ± 5 years, 36% women, 56% with reduced LVEF (rLVEF), 20% intermediate LVEF (iLVEF) and 24% preserved LVEF (pLVEF). Regarding NYHA class, 25%, 55% and 20% were respectively at class I, II and III. MoCA median score was 20 (IQR=16-22). Patients performed worse in delayed recall (Md=2; IQR=0-3), executive function (Md=2; IQR=1-4) and abstraction (Md=1; ICR=0-1) subtests. Overall 42% and 29% of patients showed mild and severe CI. Patients showing severe CI had lower education (85% ≤ 4 years old; $U=7.186$, $p=0.007$) and lower income (85% vs 34% with family monthly income lower than 1000€; $X^2=9.8$, $p=0.020$). They also needed more help of a caregiver to manage their medication ($U=4.703$, $p=0.030$). No significant differences were found in NYHA class nor in FEVE. In cognitive assessment, severe impaired patients performed worse in all MoCA subtests, with the exception of the orientation subtest ($K=4.701$, $p=0.095$). No differences were found between severe and mild cognitive impaired patients in their performance in the abstraction subtest ($U=0.648$, $p=1.0$). Regarding delayed recall task, patients with severe CI needed significantly more recognition clues than the remaining in order to recall the word list ($X^2=4.678$, $p=0.031$). In the behaviour checklist, these patients also showed great need for additional explanations ($X^2=8.8$; $p=0.003$), more tiredness during execution of the cognitive tasks ($X^2=4.5$, $p=0.033$) and less awareness of their errors ($X^2=4.8$; $p=0.028$). In the regression model, explaining overall 42% of total variance, only education ($p=0.048$) showed an independent association with severe CI. Higher education revealed a significant protective effect (OR=0.582; 95% CI: 0.341 to 0.994). **Conclusions:** Severe CI was found in 24% of HF patients, being associated with less education. These patients also showed specific behaviours during cognitive assessment that may be taken into consideration, in order to tailor the assessment procedures in clinical trials. Moreover, HF patients with severe CI showed more difficulties in managing their medication independently, limiting their capacity for good therapeutic adherence. Despite these preliminary data, cognitive function in HF patients should be further studied, to better understand cognitive prognosis in these patients. **Acknowledgments:** This work is supported by ERDF through POCI-01-0145-FEDER-007746, funded by COMPETE2020, National Funds through FCT, within CINTESIS(UID/IC/4255/2013), and Project-»NORTE-010145-FEDER-000026 - Symbiotic technology for societal efficiency gains: Deus ex Machina», financed by NORTE2020 under PORTUGAL2020.

P89: THE EFFECT OF DIZZINESS IN PATIENTS WITH COGNITIVE IMPAIRMENTS. Seunghee Na, In-Uk Song (Department of Neurology, Incheon St. Mary's Hospital, the Catholic University of Korea, Incheon, Korea)

Background: Dizziness is a false spatial sensation such as spinning, floating, unsteadiness. There have been several reports that dizziness, especially vestibular vertigo may be associated with cognitive decline, poor concentrating, and psychiatric problem such as depression in general population. However, the correlation between the dizziness and the degree of cognitive dysfunction in patients with diagnosed

cognitive impairment such as mild cognitive impairment (MCI) or dementia is not fully elucidated. **Objective:** we performed a single-center, pilot research which examining various tests evaluating dizziness in patients with MCI or dementia and their association with the cognitive dysfunction. **Methods:** We performed a cross-sectional analysis using outpatient memory clinic data. We included 41 patients with MCI or dementia scored less than CDR 2 using Seoul neuropsychological screening battery (SNSB), from February 1, 2018 to May 31, 2018. Patients with Parkinson's disease or atypical Parkinson's disease were excluded. We collected demographics, self-reporting dizziness questionnaires such as dizziness handicap inventory (DHI, 0-100 points, higher scores indicating more severe handicap) and The University of California Los Angeles Dizziness Questionnaire (UCLA-DQ, 5-25 points, higher scores indicating more severe handicap) in addition to the results of neuropsychological battery. **Results:** We enrolled total 41 patients; 32 patients with mild cognitive impairment, 9 patients with dementia. Twenty-two patients had no complaints of dizziness, but remaining 19 patients reported subjective dizziness (Table 1). Baseline characteristics including demographics, short-form of geriatric depression scale (sGDS), NPI, and frequencies of taking cholinesterase inhibitors (ChEIs) were not different between the two groups (Table 1). Interestingly, the DHI values were significantly correlated with sGDS scores in the patients with dizziness ($p=0.043$, $r=0.314$), suggesting MCI or dementia patients with dizziness might be at risk of depression. Next, we evaluated whether the cognitive dysfunction is different between two groups in detail using neuropsychological battery (Table 2). The patients with dizziness showed significantly poorer performance in Rey-complex figure copy (RCFT-copy), Korean version of Boston naming test (K-BNT), and controlled oral word association test-phonemic (COWAT-p) than the patients without dizziness, suggesting certain cognitive dysfunctions might be associated with dizziness. **Conclusion:** Our findings indicate that dizziness is associated with low performance in several cognitive tests and depression scale. Although the nature of dizziness was not specified, the results suggest that complaining of dizziness might be related with more severe cognitive dysfunction. Furthermore, alleviating dizziness symptom in patients with cognitive impairment might be helpful to improve cognitive decline or behavioral symptoms such as depressive mood. Therefore, prospective, large scale-multicenter studies are needed to confirm the clinical impact of dizziness on neuropsychiatric symptoms and cognitive impairment in patients with MCI or dementia.

Table 1
Demographics and clinical features

	Dizziness		p value
	No (DHI = 0) N=22	Yes (DHI > 0) N=19	
DHI	0	10.63 ± 11.2	
UCLA-DQ	5.10 ± 0.44	9.31 ± 4.22	
Age	72.96 ± 9.69	74.05 ± 6.70	0.790
Female (%)	16 (69.6%)	15 (79.0%)	0.491
Dementia	7 (30.4%)	2 (10.5%)	0.118
Diabetes	7 (30.4%)	6 (31.6%)	0.936

Hypertension	14 (60.9%)	10 (52.6%)	0.291
Ischemic heart disease	1 (4.3%)	2 (10.5%)	0.439
Symptomatic stroke	2 (8.7%)	0 (0.0%)	0.188
Dyslipidemia	8 (34.8%)	6 (31.6%)	0.826
Education level (years)	7.77 ± 4.89	5.32 ± 5.44	0.150
CDR	0.55 ± 0.21	0.53 ± 0.11	0.719
CDR-SB	1.84 ± 1.65	1.53 ± 1.06	0.786
MMSE	23.55 ± 3.69	21.52 ± 4.13	0.101
sGDS	4.73 ± 4.26	5.53 ± 4.05	0.446
NPI	6.36 ± 8.97	3.16 ± 5.15	0.503
Taking ChEIs	15 (65.2%)	7 (36.8%)	0.067
Taking SSRIs	6 (26.1%)	3 (15.8%)	0.418

Values are shown as mean ± standard deviation or number (%). DHI, dizziness handicap inventory; UCLA-DQ, The University of California Los Angeles Dizziness Questionnaire; CDR, the Clinical Dementia Rating; CDR-SB, Clinical Dementia Rating Sum of Boxes; MMSE, Mini-Mental State Examination; sGDS, SGDS = Short Geriatric Depression Scale; NPI, the Neuropsychiatric Inventory; ChEIs, Cholinesterase inhibitors; SSRIs, Selective serotonin reuptake inhibitors.

Table 2
Results of Neuropsychological battery

	Dizziness		p value
	No (DHI = 0) N=22	Yes (DHI > 0) N=19	
Digit span forward	5.14 ± 1.58	5.26 ± 2.08	0.774
Digit span backward	3.00 ± 1.41	2.42 ± 1.50	0.130
Korean-Boston naming test	34.45 ± 11.57	26.68 ± 11.92	0.036
RCFT copy	27.32 ± 9.33	22.32 ± 9.65	0.025
SVLT delayed recall	2.82 ± 2.48	1.89 ± 2.23	0.244
RCFT delayed recall	6.00 ± 6.79	3.63 ± 5.26	0.136
COWAT-animal	10.82 ± 4.08	8.95 ± 3.80	0.186
COWAT-phonemic	20.63 ± 9.33	7.59 ± 7.12	<0.001
Stroop test-color reading	64.42 ± 28.74	46.63 ± 34.50	0.171

Values are shown as mean ± standard deviation; RCFT, the Rey-complex figure test; SVLT, Seoul verbal learning test; COWAT, Controlled oral word association test.

P151: SELECTION OF DEPRESSION-SPECIFIC DEMENTIA CASES WITH REPLICATION IN TWO COHORTS. Donald R. Royall^{1,4}, Raymond F. Palmer³ ((1) Department of Psychiatry, The University of Texas Health Science Center at San Antonio (UTHSCSA), San Antonio, Texas, USA; (2) Department of Medicine, UTHSCSA, San Antonio, Texas, USA; (3) Department of Family & Community Medicine, UTHSCSA, San Antonio, Texas, USA; (4) South Texas Veterans Health Administration Geriatric Research Education and Clinical Center (GRECC), San Antonio, Texas, USA)

Background: Depressive symptoms, age, and the apolipoprotein E (APOE) ε4 allele are independently associated with our "agnostic" omnibus dementia severity metric i.e., the latent variable "δ" (for "dementia"). We have identified the

serum protein mediators of each predictor's unique association with δ in the Texas Alzheimer's Research and Care Consortium (TARCC) (N = 3,500). The biomarker profiles are distinct. Thus, these dementia risks appear to effect conversion to clinical "Alzheimer's Disease" (AD) by independent means. If so, then it becomes necessary to distinguish individuals demented by these processes from AD-specific dementia conversions. Serum resistin partially mediates the adverse effects of depressive symptoms on δ in TARCC and fully attenuates depression's = twofold 5yr conversion risk. **Objectives:** Here we demonstrate our ability to select individuals demented solely by depression's effect, and replicate their higher resistin levels in both TARCC (serum) and the Alzheimer's Disease Neuroimaging Initiative (ADNI) (N = 1,750). **Methods:** We recently validated a δ homolog, engineered to replicate across TARCC and ADNI (i.e., "dT2A). dT2A is indicated by a common battery of six cognitive measures. dT2A's target indicator is informant-rated Instrumental Activities of Daily Living (IADL) in TARCC and the Functional Activities Questionnaire (FAQ) in ADNI. First, we constructed dT2A in both cohorts. No covariate adjustments were applied to the raw data. Next, we adjusted dT2A for scores >10/30 on the Geriatric Depression Scale (GDS). Next, we regressed the adjusted and unadjusted dT2A composites. Next, we identified the thresholds for dementia conversion for both composites, in both datasets, by Receiver Operating Characteristic Curve (ROC) analysis. The thresholds were set at Specificity = 0.85. Next, we dichotomized each cohort into "demented" and "non-demented" cases, by both the adjusted and unadjusted composites. Next, we compared the adjusted and unadjusted classifications in a CHI-SQ table. "Off-diagonal" cases represent individuals whose classification changes when depression's unique effect on δ is considered. Serum (TARCC) and plasma (ADNI) resistin levels were contrasted across these groups, and the fraction of "AD" cases demented by GDS >10 in each cohort was estimated. **Results:** dT2A's unadjusted model had excellent fit in both cohorts. The GDS adjusted models also fit well [i.e., TARCC: CHI SQ = 50.9 (7), p < 0.001; CFI = 0.998; RMSEA = 0.042; ADNI: CHI SQ = 71.7 (7), p < 0.001; CFI = 0.994; RMSEA = 0.064]. The adjusted composites achieved high AUCs for AD's discrimination from NC [i.e., TARCC: AUC = 0.964 (0.976-0.985); ADNI: AUC = 0.988 (0.983-0.993)]. The adjusted and unadjusted composites were strongly correlated in both datasets (i.e., TARCC: r = 0.987, p < 0.001; ADNI: r = 0.998, p < 0.001). Both regressions exhibit GDS effects on dT2A. The vast majority of participants were "on-diagonal" given selection against clinically depressed cases by both studies. Regardless, n = 36 participants, 2.82% of all TARCC "AD" cases, were identified as being demented by their depressive symptom burdens. n = 4 (0.07% of ADNI's "AD" cases) were demented by depression. The adversely affected off-diagonal group had significantly higher resistin levels in TARCC (p = 0.006). Plasma resistin levels could not be replicated in ADNI because of the small number of off-diagonal cases. **Conclusions:** This analysis provides proof of concept for the rational selection of anti-dementia targets, and offers a foundation for precision anti-dementia therapy. 1-3% of well-characterized "AD" cases are demented solely by the effect of depressive symptoms. Such cases can be identified as individuals, and may revert back to non-demented states with treatment of depression's specific effect, mediated through resistin. It is currently unknown whether "effective" antidepressant treatment has effects on either δ or resistin. However, cholinesterase-inhibitors have been reported to lower serum resistin and may have

a role in the treatment of depressed "AD" cases. In all, 20% of well-characterized "AD" cases appear to be demented by AD-independent processes. This may explain the similar fraction of amyloid negative "AD" cases in ADNI and other cohorts.

Figure 1

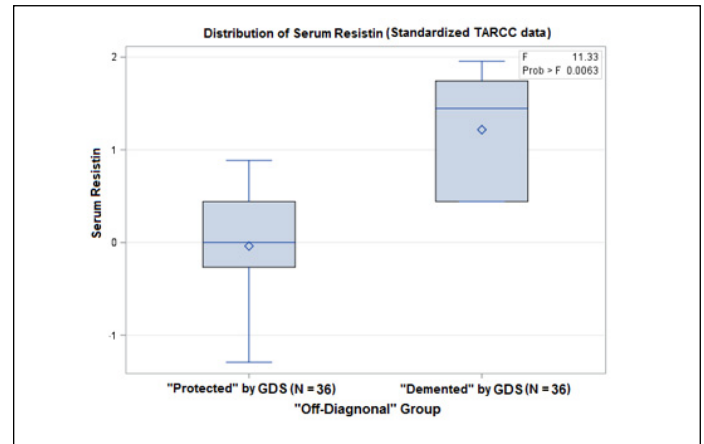

P152: SELECTION OF SENILITY-SPECIFIC DEMENTIA CASES WITH REPLICATION IN TWO COHORTS. Donald R. Royall^{1,4}, Raymond F. Palmer³ ((1) Department of Psychiatry, The University of Texas Health Science Center at San Antonio (UTHSCSA), San Antonio, Texas, USA; (2) Department of Medicine, UTHSCSA, San Antonio, Texas, USA; (3) Department of Family & Community Medicine, UTHSCSA, San Antonio, Texas, USA; (4) South Texas Veterans Health Administration Geriatric Research Education and Clinical Center (GRECC), San Antonio, Texas, USA)

Background: Age, depressive symptoms, and the apolipoprotein E (APOE) ϵ 4 allele are independently associated with our "agnostic" omnibus dementia severity metric i.e., the latent variable " δ " (for "dementia"). We have identified the serum protein mediators of each predictor's unique association with δ in the Texas Alzheimer's Research and Care Consortium (TARCC) (N = 3,500). The biomarker profiles are distinct. Thus, these dementia risks appear to effect conversion to clinical "Alzheimer's Disease" (AD) by independent means. If so, then it becomes necessary to distinguish individuals demented by these processes from AD-specific dementia conversions. Serum Insulin-like Growth Factor Binding Protein-2 (IGF-BP2) partially mediates the adverse effects of age >80 yr on δ in TARCC as well as age's = twofold 5yr conversion risk. **Objectives:** Here we demonstrate our ability to select individuals demented solely by age's effect, and replicate their lower IGF-BP2 levels in both TARCC (serum) and the Alzheimer's Disease Neuroimaging Initiative (ADNI) (N = 1,750). **Methods:** "dT2A" is a δ homolog engineered to replicate findings between TARCC and ADNI. dT2A is indicated by a battery of six cognitive measures common to both cohorts. dT2A's target indicator is informant-rated Instrumental Activities of Daily Living (IADL) in TARCC and the Functional Activities Questionnaire (FAQ) in ADNI. First, we constructed dT2A in both cohorts. No covariate adjustments were applied to the raw data. Next, we adjusted dT2A for age >80yrs. Next, we regressed the adjusted and unadjusted dT2A composites. Next, we identified the thresholds for dementia conversion for both composites, in

both datasets, by Receiver Operating Characteristic Curve (ROC) analysis. The thresholds were set at Specificity = 0.85. Next, we dichotomized each cohort into “demented” and “non-demented” cases, by both the adjusted and unadjusted composites. Next, we compared the adjusted and unadjusted classifications in a CHI-SQ table. “Off-diagonal” cases represent individuals whose classification changes when age’s unique effect on δ is considered. The serum (TARCC) and plasma (ADNI) IGF-BP2 levels were contrasted across these groups, and the fraction of “AD” cases demented by APOE in each cohort was estimated. **Results:** dT2A’s unadjusted model had excellent fit in both cohorts. The age adjusted models also fit well [i.e., TARCC: CHI SQ = 61.5 (7), $p < 0.001$; CFI = 0.997; RMSEA = 0.046; ADNI: CHI SQ = 73.1 (7), $p < 0.001$; CFI = 0.994; RMSEA = 0.065]. The adjusted composites achieved high AUCs for AD’s discrimination from NC [i.e., TARCC: AUC = 0.960 (0.952-0.967); ADNI: AUC = 1.0 (0.999-1.0)]. The adjusted and unadjusted composites were strongly correlated in both datasets (i.e., TARCC: $r = 0.97$, $p < 0.001$; ADNI: $r = 0.99$, $p < 0.001$). Both regressions exhibit age effects on dT2A. The vast majority of participants were “on-diagonal”. Regardless, $n = 179$ TARCC participants, 7.6% of all “AD” cases, were identified as being demented by their age >80 . $n = 15$ (4.4% of “AD” cases) were demented by age in ADNI. The adversely affected off-diagonal group had significantly lower serum IGF-BP2 levels in TARCC. Plasma IGF-BP2 levels were not available in ADNI. **Conclusions:** This analysis provides proof of concept for the rational selection of anti-dementia targets, and offers a foundation for precision anti-dementia therapy. 4-8% of well-characterized “AD” cases are demented solely by the effect of age. Such cases can be identified as individuals, and may revert back to non-demented states with effective treatment of age’s unique effect, partially mediated through IGF-BP2 and other “somatomedins”. In all, 20% of well-characterized “AD” cases appear to be demented by AD-independent processes. This may explain the similar fraction of amyloid negative “AD” cases in ADNI and other cohorts.

Figure 1

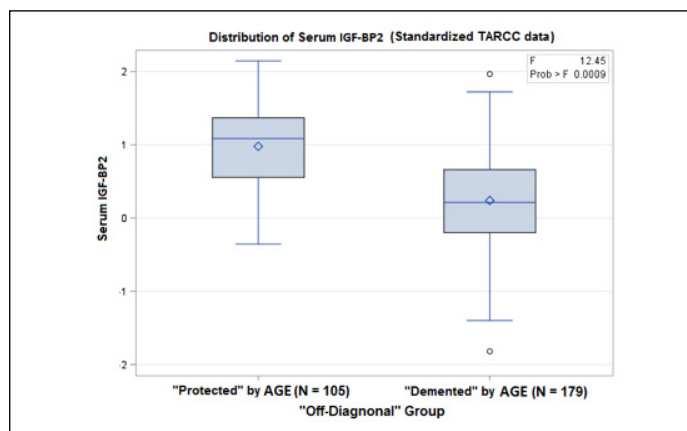

P153: ASSESSMENT AND SPEECH-LANGUAGE INTERVENTION PROGRAM IN NON-FLUENT PRIMARY PROGRESSIVE APHASIA: A CASE STUDY. Beatriz Valles-González¹, Vicent Rosell-Clari^{1,2} ((1) *Speech and Language Pathology Clinic. Lluís Alcanyís Foundation-Universitat de Valencia*; (2) *Basic Psychology Department. Universitat de Valencia*)

Background: Primary Progressive Aphasia (PPA) is a syndrome where language disorders manifest as an initial symptom when expressing and comprehending language and therefore lead to a dramatic loss of the ability to communicate effectively. Non-Fluent Primary Progressive Aphasia (NF-APP) is a type of PPA characterized by the presence of agrammatism, marked effort in the production of speech associated with apraxia, non-fluent expressive language, phonemic paraphasias, and dysprosody. **Objectives:** This research sought to know the linguistic-cognitive profile of a patient with PPA-NF and evaluate the effectiveness of a language intervention program aimed at improving the affected linguistic-cognitive skills. **Methods:** A case study was designed. A male adult of 60 years right handed whit diagnoses of NF-PPA was selected. The initial symptoms date from 2012 and anticipated the future presence of verbal apraxia. As of this date, his oral expression has worsened. The initial symptoms were: phonemic paraphrases, faults in the access to the lexicon, reduction of the grammatical structure of the sentences, mental blocks, and rhythm failures. The main alterations were: substitutions of words and syllables, and articulatory disorders. The results of the patient’s brain MRI (05/30/2013) showed a «minimal left frontal atrophy”. At the end of July 2016 the patient was evaluated through two types of tests adapted to the Spanish population, which allowed to identify cognitive-linguistic symptoms in this type of disorder and which were useful in the task of designing the speech and language intervention program. One of them was the Addenbrooke’s Cognitive Examination-III or ACE-III Spanish version (Matías-Guiu et al., 2015), this cognitive test assessments five cognitive domains: attention, memory, verbal fluency, language and visuospatial function; the other was the MetAphAs Test (Rosell-Clari & Hernández Sacristán, 2014), which is a protocol for to assessment metalinguistic skills in patients with aphasia that includes 40 items distributed in six sections, namely: 1) Internal language, ability to inhibit and discourse. 2) Control of concurrent semiotic procedures. 3) Paraphrastic skills and associated phenomena. 4) Say referral and associated phenomena. 5) Monitoring capacity. Contextualization marks. 6) Displaced Uses of Language and Theory of Mind (ToM). Based on this initial evaluation, the patient’s level of functioning was analyzed and the speech and language intervention program was designed taking into consideration the particular profile of the individual case under study. The general objective was oriented to improve oral communication and linguistic functioning. The specific objectives selected were: improving oral motor skills, ToM skills, lexical access, recent memory, oral expression and the ability to read the context. Also different materials and strategies focused on these areas were organized. The designed plan was applied over eighteen months (between December 2016 and January 2018), in a forty-five minute weekly session. Exercises were delivered each week at home. A second assessment was made six months later and a third was developed after 18 months of treatment. The results obtained were compared and analyzed from a qualitative as well as a quantitative point of view. **Results:** The results show that these tests are useful

to determine the cognitive-linguistic deficits in patients with NF-PPA and also serve as a basis for the scaffolding of linguistic and cognitive rehabilitation. The patient improved his ability to nominate and in the articulation of two-syllabic words, verbal fluency maintained the same level and some skills worsened as it was the case of the understanding of complex oral texts and the use of grammatical elements, in their oral and written expression. Regarding cognition, there was an improvement in the visuospatial skills, but a marked deterioration in recent memory. The patient also presents a limited level of communication due to severe difficulties in oral expression compensated by using isolated words at low speed or writing very short messages. With respect to the scores obtained when evaluating the patient with MetAphAs, statistically significant differences were observed when comparing the scores obtained in July 2016 with those obtained in December 2016 or January 2018. No statistically significant differences were observed when comparing the scores obtained in December 2016 and January 2018. That is, the patient made an improvement in the first half year of rehabilitation that is maintained for a year after.

Table 1
Descriptive statistics MetAphAs

	Minimum	Maximum	Sum	Media	Desv. typ.
MetAphAs. July 2016	0	4	74	1,85	1,167
MetAphAs. December 2016	0	4	94	2,35	1,210
MetAphAs. January 2018	0	4	96	2,40	1,277
Evolution MetAphAs.					
				Wilcoxon Test	
MetAphAs. July 2016 vs December 2016				0,030*	
MetAphAs. July 2016 vs January 2018				0,013*	
MetAphAs. December 2016 vs January 2018				0,770	

*Significance level 0.05 Regarding the results in the evaluation made with the ACE III, no significant differences were observed when comparing the scores obtained in July 2016 with those obtained in November 2016 or in December 2017. Nor when comparing the scores obtained in November 2016 and December 2017. This is interpreted as maintaining the patient's his cognitive state in a general way, although specific variations can be observed.

Table 2
Descriptive statistics ACE

	Minimum	Maximum	Sum	Media	Desv. typ.
ACE July 2016	1	21	89	8,09	6,833
ACE November 2016	1	24	80	7,27	7,030
ACE December 2016	1	23	89	8,09	6,745
Evolution ACE.					
				Wilcoxon Test	
ACE July 2016 vs November 2016				0,172	
ACE July 2016 vs December 2017				0,798	
ACE November 2016 vs December 2017				0,236	

Conclusions: This case study shows that patients with NF-PPA can improve their linguistic-cognitive functioning,

but it is necessary to use tests that are useful to establish the initial profile of functioning, aspect absolutely necessary in the selection of the ideal objectives of the intervention program. Key words: Non-Fluent Primary Progressive Aphasia, assessment, speech-language intervention.

P154: PREDICTION OF APOE E4 BURDEN FROM COGNITIVE ASSESSMENT. Royall DR^{1,4}, Palmer RF³ for the Alzheimer's Disease Neuroimaging Initiative* ((1) *Departments of Psychiatr1, (2) Medicine, (3) amily & Community Medicine, (4) The University of Texas Health Science Center at San Antonio and the South Texas Veterans Health Administration Geriatric Research Education and Clinical Center (GRECC)*)

Background: We use theory-driven confirmatory factor analysis (CFA) in a Structural Equation Model (SEM) framework to construct relatively error free, continuous latent measures of dementia severity. However, our approach can derive the cognitive correlates of ANY target variable. In this analysis, we derive the cognitive correlates of the apolipoprotein E (APOE) ε4 allele in data from the Alzheimer's Neuroimaging Initiative (ADNI) (N = 1,750). Methods: First, we regressed APOE ε4 burden onto an ad hoc selection of cognitive measures. Those exhibiting statistically weak associations with ε4 burden (i.e., $r < 0.25$) were deleted. Six measures were retained (Figure 1). Next, we fixed the surviving regression weights. Next, we introduced a latent variable indicated by the same set of measures. This variable, i.e., "g", represents the fraction of Spearman's general intelligence factor "g" that is residual (i.e., unrelated) to APOE ε4 burden. Next, we fixed g' s parameters. Then, we removed the regression paths from the model. Next, we introduced a second latent variable, i.e., "d". d represents the fraction of g that IS related to APOE ε4 burden. We confirmed d's significant association with observed APOE ε4 burden by correlation. Next, we used observed APOE ε4 burden as the "target" indicator of a bifactor δ "paralog" i.e., "dAPOE". In genetics, a paralog is a gene descended from an ancestral gene in the same species but often having a novel function. dAPOE's residual in d (i.e., the fraction of d that is NOT related to APOE ε4 burden) was labeled "g". At this point, dAPOE's parameters were fixed. Next, observed APOE ε4 burden was removed from dAPOE's indicators, leaving only cognitive indicators. We confirmed this construct's association with APOE ε4 burden by correlation. dAPOE's association with APOE ε4 burden was compared with CDR-SB's by multivariate regression. The entire analysis was replicated in TARCC's data. **Results:** dAPOE's final model had excellent fit. [i.e., CHI SQ = 104.04 (15), $p < 0.001$; CFI = 0.987; RMSEA = 0.052]. dAPOE correlated significantly with APOE ε4 burden ($r = 0.97$, $p < 0.001$) (Figure 1). dAPOE's association with APOE ε4 burden was independent of both CDR-SB and ADAS-Cog, stronger than both effects and largely attenuated both. **Conclusions:** This analysis provides proof of concept for our ability to accurately predict APOE ε4 burden from cognitive performance alone. Our approach implicates intelligence as the mediator of amyloid's associations with cognitive performance. Because g is "indifferent" to its cognitive indicators, we should be able to achieve similar results from any convenient cognitive battery including, but not limited to, telephone assessments, bedside screening measures, and /or the itemsets of individual screening tests.

Figure 1

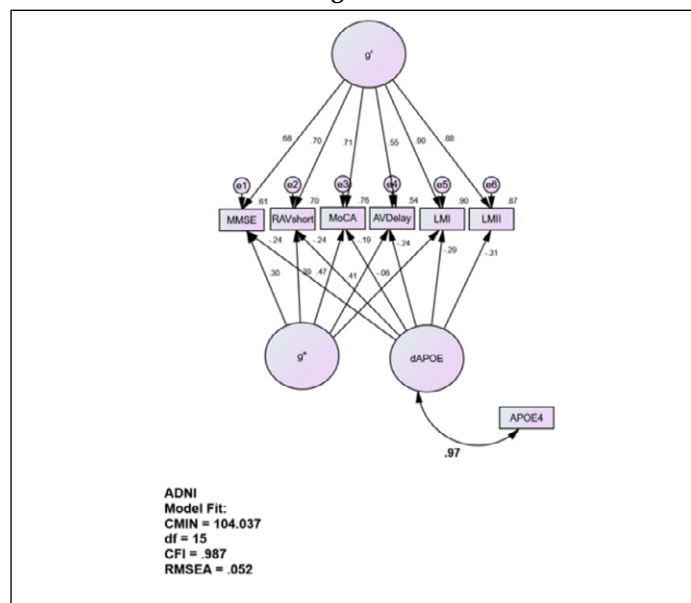

P155: CLINICAL EFFECTS OF ORAL TRAMIPROSATE IN APOE: COULD TELEMEDICINE IMPROVE NEUROCOGNITIVE DISORDERS DETECTION AND DIAGNOSIS IN NURSING HOME? Armelle Leperre-Desplanques¹, Isabelle Hauger², Sylvain Gaulier¹, Antonis Politis³, Shima Mehrabian⁴, Audrey Maillat¹, Pierre Krolak-Salmon¹ (1) *Clinical and Research Memory Centre, Lyon Institute for Elderly, Hospices Civils de Lyon, Inserm UMR1028, CNRS UMR 5292, Lyon University, France*; (2) *Résidence Talanssa, Talence, France*; (3) *National and Kapodistrian University of Athens, Athens, Greece*; (4) *Clinic of Neurology, UH "Alexandrovska", Medical University, Sofia, Bulgaria*)

Background: There is a lack of neurocognitive disorders (NCD) detection in primary care, including in the nursing home setting (NH). Possible explanation factors in NH include general practitioner's (GP) limited consultation time, unawareness of diagnosis guidelines and tools, difficulties to refer to NCD specialists and disabled patient mobilisation. Thereby, telemedicine could be a way to improve access to specialist and NCD diagnosis. **Method:** Three countries (Bulgaria, France, Greece) participating in the European Joint Action "Act on Dementia" (Work Package 4) propose to test telemedicine for NCD detection/diagnosis in some NH, with or without dedicated units for NCD patients. Face to face workshops and conference calls enable to share similar NCD detection and data collection tools. NH teams (nurses and sometimes GPs) were trained and the experiments implemented from April to June 2018. **Results:** Within 500 people from 7 NH participating to the experiments (1 in Bulgaria [Bankia] ; 4 in Greece [Larissa, Alexandroupolis, Vari, Athens]; 2 in France [Villeneuve d'Ornon, Pessac], patients characteristics, cognitive and behavioral scales, diagnosis and post diagnosis supports are collected for the telemedicine consultations eligible patients. Qualitative interviews including barriers and facilitators for NCD telemedicine experiment are performed with NH teams and patients. **Conclusion:** These experiments describe the feasibility of telemedicine for NCD detection/diagnosis in NH from 3 European countries with different economical resources (from 1 to 5 per capita gross domestic product), based on a

shared detection/diagnosis approach. Telemedicine for NCD could be all the more useful for countries with few resources and specialists and whose populations are not any less exposed to NCD.

P156: COGNITIVE BLACKOUTS IN MILD COGNITIVE IMPAIRMENT OF THE AMNESTIC TYPE AND MILD ALZHEIMER'S DEMENTIA. Georg Adler, Agnies Marczak, Jana Binder, Katharina Gnosa (*Institut für Studien zur Psychischen Gesundheit, Mannheim, Germany*)

Background: Cognitive blackouts, e.g. moments of amnesia, disorientation, or perplexity may be an early sign of incipient Alzheimer's dementia (AD). On the basis of interviews with patients with mild AD we developed a short questionnaire describing frequent self-observations in patients with beginning AD, the checklist for cognitive blackouts (CCB), and evaluated it cross-sectionally in users of a memory clinic. The 5 items of the CCB are: Within the last six months how often did it happen to you that (1) ... you wanted to get something from another room and when you go there you had forgotten what it was that you went there for? (2) ... you forgot to keep a date or an appointment or would have forgotten them without being reminded about it beforehand (e.g. by a calendar or by others)? (3) ... you took a break from reading a book or a text and when you returned to it you had serious difficulties in recalling what you had read or picking up where you had left off? (4) ... you had to think about what month it is? (5) ... you had significant difficulties finding your way at a place that was new to you (e.g. in a hotel or locating your car in a big shopping center's parking lot)? For items 2 to 5, the frequency of occurrence of the respective observations is graded as "0" (for "never"), "1" (for "rarely" or "less than once a week"), "2" (for "frequently" or "once or several times a week"), and "3" (for "permanently" or "once or several times a day"). Item 1, the frequency of which had been found to be inversely correlated with cognitive impairment, is used to compensate for underreporting and is graded in the reverse sense. For each of these items 0 to 3 points are issued, leading to CCB scores between 0 and 15. **Objective:** Evaluation of a new checklist for cognitive blackouts (CCB) for the early recognition of subjects with amnesic mild cognitive impairment and mild AD. **Methods:** The CCB was evaluated in 130 consecutive users of our memory clinic, 81 women (62%) and 49 men (38%) at ages between 50 and 85 years (mean: 62.7 years). Subjects with dementing disorders other than AD, Parkinson syndrome or a diagnosis of depression were not included. Assessment of cognitive performance and assignment to the diagnostic groups of "no cognitive impairment" (NCI), "mild cognitive impairment of the amnesic type" (MCIa) and "mild AD" (mAD) was performed by means of the Structured Interview for the Diagnosis of dementia of the Alzheimer type, Multi-infarct dementia and dementias of other aetiology according to ICD-10 and DSM-III-R (SIDAM). If appropriate, further clinical, laboratory or imaging investigations were initiated. After a normal distribution of the CCB values had been ascertained, differences in the CCB score between diagnostic groups were examined by a one-way ANOVA and subsequent Student t-tests. For the prediction of diagnosis by means of the CCB score a binary logistic regression analysis was applied, using a CCB cutoff score of >7. Relationships between CCB score and SIDAM syndromes or scores were studied by means of linear regression analyses using the Pearson correlation coefficient,

relationships between CCB score and responses to the SMI questions by Student t-tests. **Results:** NCI was found in 67 subjects (52%), MCIa in 41 (31%) and mAD in 22 (17%). A one-way ANOVA revealed significant differences of the CCB score for subjects with NCI, MCIa and mAD ($P<0.001$). Subsequent t-tests showed significantly increased values in comparison with NCI subjects for subjects with MCIa ($P<0.005$) and subjects with mAD ($P<0.001$). The binary logistic regression analysis with the CCB score as independent variable (cutoff >7) and diagnosis (NCI versus MCIa/mAD) as dependent variable showed a significant improvement of classification by 12.3% ($P<0.001$). The positive predictive value of the CCB score for MCIa or mAD was 69.2%, the negative predictive value was 84.8%. There were significant negative correlations between the CCB score and the SIDAM syndromes and scores. Correlation with the MMSE score was -0.426 ($P<0.001$). Among the SIDAM syndromes, the correlations were highest for "orientation" ($R=-0.432$; $P<0.001$) and "short-term memory" ($R=-0.386$; $P<0.001$). **Conclusions:** The CCB allowed a prediction of MCIa or mAD with a positive predictive value of 69.2% and a negative predictive values of 84.8% in the users of an outpatient memory clinic. It was negatively correlated with cognitive performance and positively correlated with depressive symptoms. Thus, the CCB may be a helpful tool for screening purposes and may be readily applied in general medicine settings. In further studies underway the relationship of the CCB to known risk factors and the course of cognitive performance are examined.

P157: FEASIBILITY OF THE NEUROPSYCHOLOGICAL BATTERY CAMCOG-DS FOR THE DETECTION OF COGNITIVE DECLINE IN PEOPLE WITH DOWN SYNDROME. Laura Videla^{1,2,3}, Bessy Benejam¹, María Carmona-Iragui^{1,2,3}, Susana Fernández¹, Isabel Barroeta^{1,2,3}, Sebastián Videla², Alberto Lleó^{2,3}, Rafael Blesa^{2,3}, Juan Fortea^{1,2,3} ((1) Alzheimer Unit - Down, Down Medical Center, Fundació Catalana Síndrome de Down; (2) Memory Unit of the Neurology Service of the Hospital de la Santa Creu and Sant Pau. Biomedical Research Institute of Sant Pau. Universitat Autònoma de Barcelona (3) Central Biomedical Research Center (CIBERNED))

Background: Down syndrome (DS) is a genetic disorder caused by the triplication of chromosome 21. Most people with Down syndrome will develop presenile onset Alzheimer disease (AD) by the third decade in life due to the presence of an extra copy of the amyloid precursor protein gene. Consequently, Down syndrome has been conceptualized as a genetically-determined expression of Alzheimer's disease. The increased life expectancy of people with Down syndrome in recent years has led to an increase in dementia incidence in this population. However, AD detection represents a diagnostic challenge due to the intellectual disability (ID) associated with DS and because the onset and course of the disease in DS population is not well characterized. At the Barcelona Down Medical Center and Hospital of Sant Pau, we have developed a pioneering population-based health plan with periodical evaluations to screen for AD in adults with DS in Catalonia. **Objectives:** The main objective of this work is to describe the feasibility and utility of the cognitive battery of the Cambridge Exam for Mental Disorders of the Elderly with Down Syndrome, (CAMCOG-DS) to detect cognitive decline in people with DS. **Methods:** This is a prospective cohort study. We included adults with DS with and without cognitive impairment and with different grades of Intellectual Disability (ID): mild, moderate,

severe and profound. We performed neurological and neuropsychological assessments in the Alzheimer-Down Unit, including the CAMCOG-DS. Following consensus between the neurologist and the neuropsychologist, we classified the subjects in four diagnostic groups: DS asymptomatic (DS-A), DS with prodromal AD (DS-pAD), DS with AD dementia (DS-dAD) and DS with a non-degenerative neurocognitive disorder (DS-nonDD). We used SPSS software to analyze the data and we carried out a descriptive analysis of the feasibility of the test according to diagnostic groups and grade of ID. We used receiver-operated characteristic curves of the total score in CAMCOG-DS and for all subtests to assess diagnostic performance. **Results:** From February 2014 to April 2018, we assessed 522 subjects (mean age 41.4 years, 46.2% women). The diagnostic distribution was: 24.1% of DS-dAD, 7.5% of DS-pAD, 62.1% DS-A and 6.3% had a non-degenerative neurocognitive disorder. We were able to apply the CAMCOG-DS to 63% of the sample (331 subjects). The battery showed excellent sensitivity and specificity for the detection of cognitive decline with an AUC of 0.95 in mild ID group and 0.84 in the moderate ID groups. Only 39% of subjects in the severe ID group were able to be assessed with the CAMCOG battery, and the AUC for those who were assessed with CAMCOG-DS was 0.727; none of the patients with a profound ID could complete the test. Of those who did not complete the test, 47% had advanced stage of dementia, and a large proportion had severe to profound ID. The new learning memory subtest showed greater sensitivity and specificity in the mild and moderate ID groups than the total score of the test, with an AUC of 0.966 and 0.92, respectively. **Conclusion:** The new learning memory subtest, CAMCOG-DS, can detect cognitive decline in subjects with mild to moderate ID with higher sensitivity and specificity than the global score for detecting cognitive impairment. DS could be a key population for clinical trials targeted at preclinical and prodromal AD stages. However, the difficulty of AD diagnosis in DS has led to their exclusion. Incorporation of CAMCOG-DS into the test battery would allow inclusion of the DS population into clinical trials. New neuropsychological tools are necessary to be able to evaluate the cognitive performance of those individuals with a severe to profound intellectual disability.

Figure 1

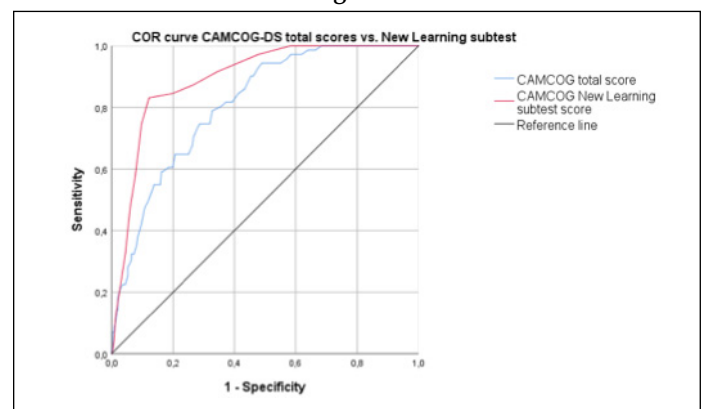

P158: DISTINCT PATTERNS OF COGNITIVE DECLINE BETWEEN EARLY-ONSET ALZHEIMER'S DISEASE AND LATE-ONSET ALZHEIMER'S DISEASE.

Adrià Tort Merino, Jaume Olives, Neus Falgàs, Mírcia Balasa, Magda Castellví, Sergi Borrego, Beatriz Bosch, María León, Ana Salinero, Guadalupe Fernández, Anna Antonell, Raquel Sánchez-Valle, Lorena Ramí, Albert Lladó (*Alzheimer's Disease and other Cognitive Disorders Unit, Neurology Service, Hospital Clínic, Barcelona, Spain*)

Background: In the last years, there has been intensive research on the differences between early onset Alzheimer's disease (EOAD) and late onset Alzheimer's disease (LOAD). Although distinct neuropsychological profiles have been identified between these populations, whether age influences AD progression (prognosis and/or severity) is still unclear. Our aim was to compare the neuropsychological patterns of cognitive decline between EOAD and LOAD patients and to assess the value of CSF total tau (t-tau) and phosphorylated tau (p-tau) as prognosis biomarkers of cognitive decline in EOAD subjects. **Methods:** We included 51 subjects with a confirmed AD CSF biomarker profile. The study sample was divided into two groups: EOAD (n=27; mean age: 58.7±4.2; years of education: 11.6±4.7, MMSE: 22.4±4.1) and LOAD (n=24; mean age: 73.7±4.8; years of education: 9.0±3.7; MMSE: 23.6±3.2). All participants were assessed both in the baseline and in a follow-up session (one year later) with a comprehensive neuropsychological battery, administered by a trained neuropsychologist. The battery encompassed five cognitive domains. The memory domain included the Free and Cued Selective Reminding Test (FCSRT) for the assessment of verbal memory, and the Landscape Test (LT) for visual memory; the language domain comprised of the Boston Naming Test (BNT), a semantic fluency task (SFT) and the auditory comprehension subtest of the Boston Diagnostic Aphasia Examination (BDAE); the praxis domain included the drawing subtest of the Consortium to Establish a Registry for Alzheimer's Disease battery (CERAD) and the ideomotor apraxia subtest of the Western Aphasia Battery (WAB); the visual perception domain included the letters and number location subtests of the Visual Object and Space Perception battery (VOSP); and the executive functions domain consisted of the Trail Making Test (Forms A and B; TMT-A/B), letter fluency test (LFT) and the Digit Span subtest of the Wechsler Adult Intelligence Scale (WAIS). Premorbid intelligence was assessed with the Spanish word accentuation test (WAT) and global cognition with the MMSE. Statistical analyses were performed using the SPSS (v.22.0) package for Windows. All analyses, a p<0.05 was considered to be significant. Demographical data and APOE-ε4 frequencies were compared using Student t-tests for independent samples and Chi-square analyses when appropriate. We ran mixed-model analyses of covariance (ANCOVA) controlling for years of education with post-hoc Bonferroni corrections to explore possible cross-sectional differences on the neuropsychological tests between EOAD and LOAD subjects. In order to compare cognitive decline in the different neuropsychological tests between the groups, we set up a repeated measures model. Finally, Pearson correlations were run in order to find possible associations between CSF biomarkers and cognitive decline. **Results:** There were no significant differences between groups in terms of gender distribution ($\chi^2=2.41$; p=.121), APOE-ε4 allele frequency ($\chi^2=5.67$, p=.225) or global cognition (t(47)=-1.18, p=.243). The EOAD group was significantly younger

(t(49)=-11.91, p<0.01) and more educated (t(49)= 2.15, p<0.05) than the LOAD group. In the baseline assessment, the EOAD group showed better performance in the drawing subtest of the CERAD battery (F(1,44)= 8.78, p<0.01) and in numbers subtest of the VOSP battery (F(1,46)= 12.83, p<0.01). Longitudinally, a greater cognitive decline of the EOAD group was observed when compared with LOAD in global cognitive function (F(1,45)= 8.60, p<0.01), the total delayed recall score of the FCSRT (F(1,42)= 4.28, p<0.05), BNT (F(1,48)=3.94, p<0.05), semantic fluency task (F(1,48)=3.89, p<0.05) and the auditory comprehension subtest of the BDAE (F(1,48)=9.68, p<0.01), and the TMT-A (F(1,46)= 8.29, p<0.01) (see fig. 1). In the whole sample, Pearson correlations showed no associations between CSF t-tau or CSF p-tau and cognitive decline in none of the standard neuropsychological tests. However, we ran the analyses for the specific groups and we found significant associations in EOAD patients between (1) decline on the ideomotor apraxia test and CSF t-tau (r= .515, p<0.01) and CSF p-tau (r= .507, p<0.01), and 2) decline in the free learning score of the FCSRT and CSF p-tau (r= .427, p<0.05). **Conclusions:** EOAD patients exhibit higher cognitive decline than LOAD in most cognitive domains during the first year of follow-up. Considering our reduced sample size and follow-up period, data regarding the role of CSF t-tau and p-tau as prognosis biomarkers of cognitive decline in EOAD subjects have to be interpreted with caution and replication is called for in further studies.

Figure 1
Cognitive decline in specific neuropsychological tests between EOAD and LOAD

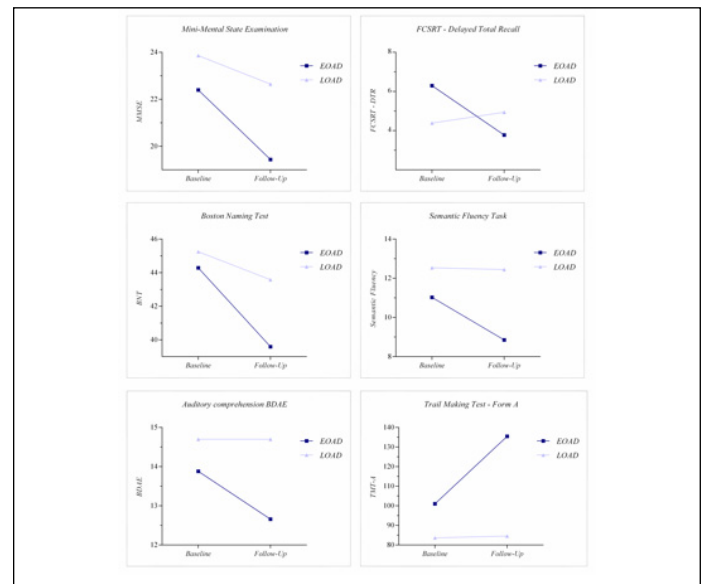

P159: HIGH LEVEL OF PLASMATIC AMYLOID AB 1-40 INCREASE THE RISK OF COGNITIVE DECLINE IN 3C STUDY WITH 14 YEARS OF FOLLOW-UP. Audrey Gabelle^{1,2,3}, Laure-Anne Gutierrez^{2,3}, Thibault Mura^{2,3}, Jean-François Dartigues^{4,5}, Olivier Rouaud⁶, Jean-Charles Lambert^{7,8,9,10}, Catherine Helmer^{4,5}, Claudine Berr³ ((1) *Memory Research and Resources Center, Montpellier University Hospital, Montpellier*; (2) *Inserm U1061, La Colombière Hospital, Montpellier*; (3) *University of Montpellier, MUSE University, Montpellier*; (4) *Bordeaux University, Inserm, Bordeaux Population Health Research Center, UMR 1219, Bordeaux, France*; (5) *CHU Bordeaux, Department of Public Health, F-33000 Bordeaux, France*; (6) *CHRU Dijon, Centre Mémoire Ressources et Recherche, Dijon, France*; (7) *CHRU de Lille, Lille, France*; (8) *INSERM U744, Lille, France*; (9) *Institut Pasteur de Lille, Lille, France*; (10) *Université de Lille Nord de France, Lille, France*)

Background: In order to develop preventive strategies, biomarkers are needed to assess people at risk of cognitive decline in the population. **Objective:** We evaluated whether plasma amyloid A β levels were associated with cognitive decline risk in a subsample of the French Three-City (3C) prospective cohort study over a 14-year follow-up period. **Methods:** We analysed 1121 participants from the 3C cohort, free from dementia at baseline, with plasma amyloid data available at baseline and at least one follow-up cognitive evaluation. Cognitive decline was assessed using the Mini-Mental State Evaluation (MMSE), the Benton Visual Retention test, the Trail-making Test and the Isaacs Set Test. Plasma A β levels were considered in tertiles. Associations between plasma A β and cognitive decline were evaluated with the multivariate mixed models adjusted for age, gender, educational level and their interactions with time. **Results:** Higher plasma A β 1-40 concentrations at baseline were associated with a higher risk of cognitive decline at MMSE (β (SE): 0.014 (0.007); $p=0.04$). A β 1-42 concentrations and A β -ratio at baseline were associated with MMSE at baseline but not with the cognitive decline within time. Relations between plasma amyloid A β levels and other cognitive tests were not statistically significant. **Conclusions:** Plasma A β 1-40 level seems associated with cognitive decline with time. These results will be consolidated with the longitudinal data from the 3C study with 17 years of follow-up.

P160: EVIDENCE THAT REGULARLY PERFORMING WORD OR NUMBER PUZZLES COULD HELP PROTECT AGAINST COGNITIVE DECLINE IN A LARGE COHORT OF ADULTS AGED 50 TO 92. Keith A. Wesnes^{1,2}, Helen Brooker^{1,2}, Clive Ballard¹, Adam Hampshire³, Dag Aarsland⁴, Zunera Khan⁴, Rob Stenton⁵, Maria Megalogeni⁴, Anne Corbett¹ ((1) *University of Exeter Medical School, University of Exeter, Exeter, UK*; (2) *Wesnes Cognition Ltd, Streatley on Thames, UK*; (3) *Imperial College London, London, UK*; (4) *King's College London, London, UK*; (5) *Manta software, Cambridge, UK*)

Background: As longevity increases it is important to understand how cognitive deterioration in older age can be prevented or at least reduced. PROTECT is a UK based study conducted entirely online, with the intention to follow volunteers aged 50 and over without dementia for 10 years (www.protectstudy.org.uk). Involving annual assessments of core aspects of cognitive function, it is designed to contribute to growing research into the influence of genetic, lifestyle, medical and other factors on cognitive ageing. **Objectives:** On study

entry, volunteers complete a series of online questionnaires and are invited to perform a range of online cognitive tests from the CogTrack System and the PROTECT Cognitive Test Battery (PCTB) on up to three occasions. Two of the lifestyle questions concern the frequency with which the volunteers engage in word and number puzzles. Previously reported analyses of the baseline cognitive data identified that for both types of puzzle, the frequency with which they were undertaken was related to the quality of a range of aspects of cognitive function; with more frequent use being associated with superior function. At the start of the second year, cognitive function was again assessed. Declines in cognitive function over the year were identified on a number of measures. The purpose of the present analysis was to determine whether the frequencies of use of the two types of puzzle had any influence on the cognitive measures which had declined over the year. **Methods:** This analysis involves the 10,360 volunteers who at study entry had undertaken cognitive testing on more than one occasion and had repeated testing a year later. The mean age was 62 years (SD= 7.1, range 50 to 92), and 7,540 were female. For each type of puzzle, 3 frequency groups were identified: those who never performed puzzles, those who performed them infrequently (occasionally or monthly), and those who performed them regularly (weekly or daily). The group sizes for the never, infrequent and regular groups were 1,572, 3,822 and 4,966 respectively for word puzzles, and 3,021, 3,318 and 4,021 for number puzzles. Four composite measures of cognitive function were analysed, three from the CogTrack tests of attention, and the fourth from the PCTB working memory tests. The attention measures reflected the intensity of focussed attention, the ability to maintain focus without moment to moment fluctuations, and the speed of cognitive processing. The fourth measure was created from 3 PCTB tests and reflected the ability to hold different types of information in working memory. For each type of puzzle, the changes over the year in the four measures of cognitive function were subject to ANCOVAs. The main factor fitted to the models was the 3 frequency levels of puzzle use, and the covariates included age, gender, education level and the baseline score. Cohen's d effect sizes were calculated using the residual error terms from the ANCOVAs. **Results:** The ANCOVAs identified statistically significant main effects of the frequency of puzzle use on all measures for both types of puzzle. The consistent pattern was for the declines to be greatest for the group who never performed puzzles, smallest or not present on the group regularly used them, with the infrequent group falling in between. For both types of puzzle, the Attentional Intensity Index not only declined significantly for all groups ($p<0.0001$), but also to a significantly different extent for each group. The differences between the never and regular groups for word and number puzzles had effect sizes of 0.12 and 0.16 respectively (both $p<0.0001$). A similar pattern was seen for the Attentional Fluctuation Index, the effect sizes of differences between the never and regular groups being 0.08 ($p<0.012$) for word and 0.12 ($p<0.0001$) for number puzzles. For Cognitive Reaction time, the group who never performed puzzles again declined significantly for both types of puzzle, the infrequent group showed declines which were not significant, while the regular group showed improvements over the year which reached significance for number puzzles ($p<0.004$). The effect size of the differences between the never and regular groups was 0.11 ($p<0.002$) for word puzzles and 0.12 ($p<0.0001$) for number puzzles. Finally, on the working memory measure, in contrast to the regular use group, the infrequent or never

groups declined significantly over the year for both types of puzzle. The differences between all 3 groups were significant for both types, and the effect sizes of the difference between regular use and never were 0.13 ($p < 0.0001$) for word and 0.19 ($p < 0.0001$) for number puzzles. **Conclusions:** This analysis has found that the frequency with which individuals aged 50 to 92 perform word and number puzzles is related to the degree to which various aspects of cognitive function decline over a year. This interesting and potentially important finding will continue to be investigated as the PROTECT study progresses and nested intervention studies are conducted.

P161: IS THE PRESENCE OF NEUROPSYCHIATRIC SYMPTOMS IN THE 5 DOMAINS OF THE MILD BEHAVIOURAL IMPAIRMENT CHECKLIST (MBI-C) ASSOCIATED WITH THE QUALITY OF CORE ASPECTS OF COGNITIVE FUNCTION IN OLDER ADULTS? Keith A. Wesnes^{1,2}, Helen Brooker^{1,2}, Byron Creese¹, Zahinoor Ismail³, Zunera Khan⁴, Maria Megalogeni⁴, Anne Corbett¹, Adam Hampshire⁴, Dag Aarsland⁴, Clive Ballard¹ ((1) *University of Exeter Medical School, University of Exeter, Exeter, UK*; (2) *Wesnes Cognition Ltd, Streatley on Thames, UK*; (3) *University of Calgary, Calgary, Canada*; (4) *King's College London, London, UK*; (5) *Imperial College London, London, UK*)

Background: The construct of Mild Behavioural Impairment (MBI) concerns the emergence at 50 years of age onwards of neuropsychiatric symptoms (NPS) which could lead to cognitive decline and dementia. The MBI checklist (MBI-C) is a recently developed 34-item scale, based on the ISTAART-AA MBI diagnostic criteria, which can be completed by the individual, informant or clinician (Ismail et al, 2017). It assesses 5 domains: decreased motivation, emotional dysregulation, impulse dyscontrol, social inappropriateness, and abnormal perception or thought content. **Objectives:** To determine whether the presence of NPS in the 5 MBI-C domains are associated with the quality of cognitive function in a large population of adults aged 50 and over. **Methods:** PROTECT is a UK based study conducted entirely online, with the intention to follow volunteers aged 50 and over without dementia for 10 years (www.protectstudy.org.uk). At the start of the second year the volunteers were asked to self-administer the MBI-C online. As part of their annual assessments they perform a range of cognitive tests from the CogTrack™ System and the PROTECT Cognitive Test Battery (PCTB), up to 3 times over 7 days. The 9 tests across the batteries assess various aspects of attention, information processing, working memory, executive function and episodic memory. Six composite indices from 8 of the tests were analysed, 4 reflecting different aspects of attention and information processing, and the others working memory capacity and executive function. The other test assessed object pattern separation using a visual episodic memory recognition procedure, and the scores for both correctly detecting previously presented stimuli as well as correctly rejecting closely similar 'lure' stimuli were analysed. For each MBI-C domain, the volunteers were divided into two groups, those who reported NPS and those who did not. Volunteers with depression, schizophrenia or other psychiatric conditions were excluded from the analysis, as were those who showed deficits to cognitive function consistent with Mild Cognitive Impairment. For the 6 composite scores, ANCOVAs were conducted for each domain, with NPS fitted as the main effect (2 levels, present or absent). The covariates included age, gender,

education and the number of times the tests were performed. For the pattern separation test, the type of stimuli was also fitted to the models, as well as an interaction term with NPS. Cohen's *d* effect sizes were calculated using the residual error terms from the ANCOVAs. Due to the number of ANCOVAs conducted, the Bonferroni correction was applied to determine statistical significance. **Results:** After exclusions, data were available for 10,793 volunteers, 7,911 females (mean age 61.3 years, SD 6.9, range 50 to 92) and 2882 males (mean age 63.9 years, SD 7.5, range 50 to 91). The consistent pattern over the 5 MBI-C domains was for volunteers who reported NPS to have poorer performance on all measures of cognitive function. NPS were associated on all domains with significant difficulties on measures both of focusing and sustaining attention. The ability to hold information in working memory was also significantly poorer in volunteers with NPS in all 5 domains. Moment to moment fluctuations in attention were significantly greater in volunteers with NPS in all but the impulse dyscontrol domain. Executive function was disrupted with NPS for the impulse dyscontrol and abnormal perception or thought content domains. The speed of processing information was not reliably disrupted in any domain. Finally, the pattern separation test on each domain showed a highly selective and statistically reliable deficit in volunteers reporting NPS on the ability to correctly identify closely similar stimuli. This measure is known to reflect activity in the hippocampal dentate gyrus, one of the 2 brain areas where neurogenesis occurs, unlike the ability to correctly detect the original stimuli. Thus, the selectively inferior scores on this measure suggest that NPS be associated with compromised neurogenesis. Overall the Cohen's *d* effect sizes of the reliable effects ranged from 0.09 to 0.24. **Conclusions:** These are the first findings of impaired cognitive function associated with the presence of NPS in each of the 5 individual domains of the MBI-C. The impairments on the domains in this analysis cover a range of core aspects of cognitive function and support the possibility that MBI symptoms could be early indicators of cognitive decline in a population aged 50 years and older. Reference: Ismail Z., Agüera-Ortiz L., Brodaty H et al (2017). The Mild Behavioral Impairment Checklist (MBI-C): A rating scale for neuropsychiatric symptoms in pre-dementia populations. *J Alzheimers Dis.* 56(3): 929–938.

P162: USING GRAPHICAL HIERARCHICAL BAYESIAN COGNITIVE PROCESS MODELS APPLIED TO COMMON MEMORY TESTS TO DETECT AD PATHOLOGY WITHIN NORMAL SUBJECTS. William R. Shankle^{1,2,3}, Junko Hara^{1,3}, Jason R. Bock¹, Dennis Fortier¹, Tushar Mangrola¹, Michael Lee², Gregory E. Alexander², William H. Batchelder², Ronald C. Petersen⁴, Walter Kremers⁴ ((1) *Medical Care Corporation, Newport Beach, CA, USA*; (2) *Dept. of Cognitive Sciences, University of California at Irvine, Irvine, CA, USA*; (3) *Pickup Family Neuroscience Institute, Hoag Memorial Hospital, Newport Beach, CA, USA*; (4) *Mayo Clinic, Rochester, MN, USA*)

Background: Animal models have shown that Alzheimer's dementia (AD) pathology first affects episodic retrieval activated by perforant path synapses onto dentate gyrus engram neurons. Human fMRI and FDG PET studies of normal, high AD risk subjects have shown relatively increased medial temporal lobe activity, which may represent increased encoding and/or storage to compensate for decreased retrieval capacity. These cognitive processes can be indirectly measured using graphical Hierarchical Bayesian Cognitive Processing (HBCP)

Figure 1

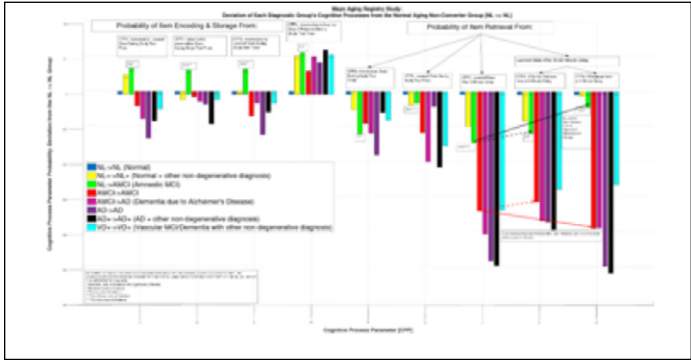

models applied to standard clinical memory tests. **Objectives:** 1. Use a validated, longitudinal sample of normal, amnesic MCI, AD and cerebrovascular disease subjects. 2. Apply graphical HBCP models to a wordlist memory task to extract underlying cognitive processes of encoding/storage, and retrieval from working and long-term memory states. 3. Assess effects of diagnosis and severity on these cognitive processes in relation to normal aging subjects who remain stable longitudinally.

Methods: Sample: Mayo Alzheimer’s Disease Patient Registry 10 Year study of subjects diagnosed at baseline as either Normal (NL), Normal with a non-degenerative abnormality (NL+; e.g., B12 deficiency), Amnesic MCI (AMCI), Alzheimer’s dementia (AD), AD plus non-degenerative disorder (AD+), Cerebrovascular Disease with a non-degenerative abnormality (VD+), or other etiologies. Subjects were annually assessed for up to 10 years. Diagnostic Groups: The following table shows the Non-Converter (diagnosis unchanged over study) and Converter (diagnosis changed over study) diagnostic groups, numbers of subjects analyzed within each group.

Group	NL	NL+	AMCI	AD	AD+	VD+	NL→AMCI	AMC→AD
Sample Size	365	110	51	191	99	51	32	44
Converter?	No	No	No	No	No	No	Yes	Yes

Cognitive Task: The AVLT 15-word memory task item responses from the initial assessment of each diagnostic group were used as input data to the model. **Markov Model:** Consisted of unlearned (U), intermediate (I: prefrontal), and learned (L: medial temporal) states connected by encoding/storage processes, plus retrieval processes from states I and L. **Analysis:** The posterior predictive distributions of each diagnostic group’s cognitive processes were inferred using graphical Hierarchical Bayesian methods. We assessed the impact of each diagnostic group on each cognitive process by subtracting its parameter probabilities from those of the NL→NL group. We computed Savage-Dickey odds ratios to determine the likelihood that a given cognitive process parameter from a given diagnostic group differed from that of the NL→NL group. **Results:** Only the NL+→NL+ and NL→AMCI groups showed (1) higher encoding/storage probabilities than those of the NL→NL group; and (2) higher delayed item retrieval probabilities at 30-60 minutes if retrieved at 5 minutes. Savage-Dickey odds ratios showed that these differences from the NL→NL groups were highly significant. **Conclusions:** By the time amnesic MCI has developed, prior delayed retrieval of information no longer improves later retrieval. Our analysis suggests that, prior to amnesic MCI, neurophysiological mechanisms can still compensate for accumulating AD pathology by: (1) using delayed retrieval to further strengthen long-term memory retrieval later on; and by (2) increasing encoding and storage into dorsolateral prefrontal and medial temporal cortices to at least partly counteract the concomitant decrease in retrieval strengths from these areas. By the time amnesic MCI has developed, AD pathology is severe enough to block these neurophysiological mechanisms. Hierarchical Bayesian Cognitive Processing models applied to wordlist memory tasks make it possible to detect AD pathology early enough to optimize therapeutic interventions that strengthen long-term memory by preserving compensatory processes of encoding, storage, and delayed retrieval.

Theme: Behavioral disorders and clinical trials

P32: EFFECT OF MEMANTINE ON BEHAVIORAL AND PSYCHOLOGICAL SYMPTOMS OF DEMENTIA (BPSD) OF ALZHEIMER’S DISEASE - STUDY OF CHANGES IN CEREBRAL BLOOD FLOW BY SPECT IMAGINGAIMS. Kiyoshi Kanaya¹, Shine Abe² ((1) MD, Geriatric medicine, Tokyo Medical University Hachioji medical center; (2) MD, Geriatric medicine, Tokyo Medical University Hachioji medical center)

Background: The mechanism of the onset of BPSD associated with Alzheimer’s disease (AD) is unclear, and the incidence and frequency of these symptoms are difficult. We conducted a retrospective study on sites of decreased cerebral blood flow(CBF) during onset along with sites of increased blood flow following administration of memantine (MEM) for three BPSD parameters consisting of «agitation/irritability», «hallucinations/delusions» and «wandering/appeal to return home» using SPECT imaging. **Method:** The study was targeted at 41 DAT outpatients diagnosed with DAT and presenting with BPSD (agitation/irritability: 11 cases, hallucinations/delusions: 19 cases, wandering/appeal to return home: 11 cases). Sites of decreased CBF during onset of BPSD were extracted using the statistical parametric mapping (SPM8) followed by an examination of their responsible lesions. SPECT was repeated about six months after additional administration of MEM followed by an examination of the correlation between sites of increased CBF attributable to MEM and improvement of symptoms. **Results:** 1 With respect to agitation/irritability, decreases in CBFwere observed in the dorsolateral prefrontal cortex bilaterally, angular gyrus, right-dominant parietal association area and posterior cingulate gyrus, while increases in CBF following administration of MEM were observed in the orbital gyribilaterally, right occipital lobe and left ventral prefrontal cortex. 2 With respect to hallucinations/delusions, decreases in CBF were observed in the posterior cingulate gyrus, occipital lobe and lt.-dominant parietal association area, while increases in CBF following administration of MEM were observed in the parietal lobe, orbital gyrus and prefrontal cortex bilaterally. 3 With respect to wandering/appeal to return home, decreases in CBF were observed in the mid-cerebellum, occipital lobe and parietal lobe, while increases in CBF following administration of MEM were observed in midcerebellum, left parietal lobe, occipital lobe, posterior cingulate gyrus, prefrontal cortex and ventral central pons. **Conclusion:** There was suggested to be a correlation between sites of CBF following administration of MEM and improvement of BPSD.

P37: CLUSTERIZATION OF BEHAVIORAL AND PSYCHOLOGICAL SYMPTOMS OF DEMENTIA (BPSD).

Timofey L. Galankin, MD, PhD², Anton Y. Beshpalov^{1,2}, Hans J. Moebius¹ ((1) *EXCIVA, Am Aukopf 14/1, Heidelberg 69118, Germany*; (2) *Valdman Institute of Pharmacology, Pavlov First Saint Petersburg State Medical University, 6/8 Lev Tolstoy Str., St. Petersburg 197022, Russia*)

Background: Regulators have addressed the persisting high medical need by opening up the range of approvable dementia medications to therapies with syndromal indication labels. Such a syndromal indication label might, for instance, cover Behavioral and Psychiatric Symptoms in Dementia (BPSD) as discussed by Sano et al (2018). Although principal component and factor analyses are commonly applied to reveal clusterization of BPSD, results cannot guide drug development efforts because clusters derived from such analyses seem to be a statistical phenomenon that cannot be visualized and interpreted in a clinically meaningful way.

Objectives: The primary aim of the present study was to characterize co-occurrence of BPSD dimensions as assessed by NPI and present the results in a format that could inform clinical development and use of existing and future BPSD treatments. To that end, we have used the NPI scores from the Aging, Demographics, and Memory Study (ADAMS) in the US. **Methods:** In the previous analyses of BPSD in patients with dementia, various tools were applied to identify clusters of the BPSD symptoms. Advantages and disadvantages of these different methods are not always obvious, particularly to non-statisticians. Thus, prior to analyzing the NPI scores from the ADAMS database, we have designed and conducted a series of simulation experiments with different degrees of complexity. Three types of simulations (A – easy, B – intermediate, C – complex) were run 100 times each to trace the capability of principal component analysis (PCA), factor analysis (FA) and cluster analysis (CA) to detect true but not false symptom associations. Each simulation had ten symptoms (1-10) that were simulated either as “signals” (random values from 1 to 12) or as “noise” (random values from 0 to 2). “Signal” simulated presence of a symptom, “noise” simulated absence of a symptom. Each pattern (symptom association or mono-symptom) was simulated with 200 subjects. The Wave A NPI data set of the Aging, Demographics, and Memory Study (ADAMS) consisted of 856 subjects. A total of 316 (36.9%) subjects who had at least 1 NPI symptom and no missing values for any of the NPI items were used for the analysis. The resulting clusters were further analyzed to extract the most prevalent symptom associations that they contained. Statistical analysis was performed in R software (version 3.4.2, 2017, The R Foundation for Statistical Computing) utilizing “Stats” inbuilt package functions: “prcomp”, “factanal”, and “kmeans”. **Results:** Simulation experiments have indicated several advantages of CA over PCA and FA: 1. CA provides each subject with his/her own group (cluster) that makes it easy to visualize the actual NPI scores and make sure that the detected associations are real. 2. Size of the clusters provide epidemiological estimates of the prevalence of each pattern. 3. CA does not ignore subjects with low composite scores for all symptoms (such subjects represent an absolute majority of the ADAMS NPI data set and are ignored by PCA and FA). 4. The number of components/factors is limited by the number of variables. In case of 10 NPI symptoms, the PCA can provide up to 10 components, FA can provide only up to 5 factors. The

CA is free of such limitations. The main disadvantage of the CA is that its use is labor-intensive comparing to PCA/FA. Since the CA correctly describes associations of NPI symptoms while the PCA and FA fail in situations with multiple overlapping associations, the CA was chosen as the main tool to evaluate the ADAMS Wave A NPI data set. CA was able to identify 13 distinct patterns of symptom associations, while PCA discovered only 3 and FA only 4 patterns. **Conclusions:** We have identified Cluster Analysis as the statistical method that: a) correctly describes clinical associations of NPI symptoms, and b) allows graphical presentation of the results in a way that is easily interpretable by non-statisticians. **Acknowledgment:** The ADAMS is a supplement to the Health and Retirement Study (HRS) data that is sponsored by the National Institute on Aging (U01-AG009740) and conducted by the University of Michigan with the specific aim of conducting a population-based study of dementia. **Literature:** Sano, M. et al. *J Prev Alz Dis* 2018;5(2):98-102

P43: THE EFFECT OF DIZZINESS IN PATIENTS WITH COGNITIVE IMPAIRMENTS.

Seunghee Na, MD, In-Uk Song, (*Department of Neurology, Incheon St. Mary's Hospital, the Catholic University of Korea, Incheon, Korea*)

Background: Dizziness is a false spatial sensation such as spinning, floating, unsteadiness. There have been several reports that dizziness, especially vestibular vertigo may be associated with cognitive decline, poor concentrating, and psychiatric problem such as depression in general population. However, the correlation between the dizziness and the degree of cognitive dysfunction in patients with diagnosed cognitive impairment such as mild cognitive impairment (MCI) or dementia is not fully elucidated. **Objective:** we performed a single-center, pilot research which examining various tests evaluating dizziness in patients with MCI or dementia and their association with the cognitive dysfunction. **Methods:** We performed a cross-sectional analysis using outpatient memory clinic data. We included 41 patients with MCI or dementia scored less than CDR 2 using Seoul neuropsychological screening battery (SNSB), from February 1, 2018 to May 31, 2018. Patients with Parkinson's disease or atypical Parkinson's disease were excluded. We collected demographics, self-reporting dizziness questionnaires such as dizziness handicap inventory (DHI, 0-100 points, higher scores indicating more severe handicap) and The University of California Los Angeles Dizziness Questionnaire (UCLA-DQ, 5-25 points, higher scores indicating more severe handicap) in addition to the results of neuropsychological battery. **Results:** We enrolled total 41 patients; 32 patients with mild cognitive impairment, 9 patients with dementia. Twenty-two patients had no complaints of dizziness, but remaining 19 patients reported subjective dizziness (Table 1). Baseline characteristics including demographics, short-form of geriatric depression scale(sGDS), NPI, and frequencies of taking cholinesterase inhibitors(ChEIs) were not different between the two groups (Table 1). Interestingly, the DHI values were significantly correlated with sGDS scores in the patients with dizziness ($p=0.043$, $r=0.314$), suggesting MCI or dementia patients with dizziness might be at risk of depression. Next, we evaluated whether the cognitive dysfunction is different between two groups in detail using neuropsychological battery (Table 2). The patients with dizziness showed significantly poorer performance in Rey-complex figure copy (RCFT-copy), Korean

version of Boston naming test (K-BNT), and controlled oral word association test-phonemic (COWAT-p) than the patients without dizziness, suggesting certain cognitive dysfunctions might be associated with dizziness. **Conclusion:** Our findings indicate that dizziness is associated with low performance in several cognitive tests and depression scale. Although the nature of dizziness was not specified, the results suggest that complaining of dizziness might be related with more severe cognitive dysfunction. Furthermore, alleviating dizziness symptom in patients with cognitive impairment might be helpful to improve cognitive decline or behavioral symptoms such as depressive mood. Therefore, prospective, large scale-multicenter studies are needed to confirm the clinical impact of dizziness on neuropsychiatric symptoms and cognitive impairment in patients with MCI or dementia.

Table 1
Demographics and clinical features

	Dizziness		p value
	No (DHI = 0) N=22	Yes (DHI > 0) N=19	
DHI	0	10.63 ± 11.2	
UCLA-DQ	5.10 ± 0.44	9.31 ± 4.22	
Age	72.96 ± 9.69	74.05 ± 6.70	0.790
Female (%)	16 (69.6%)	15 (79.0%)	0.491
Dementia	7 (30.4%)	2 (10.5%)	0.118
Diabetes	7 (30.4%)	6 (31.6%)	0.936
Hypertension	14 (60.9%)	10 (52.6%)	0.291
Ischemic heart disease	1 (4.3%)	2 (10.5%)	0.439
Symptomatic stroke	2 (8.7%)	0 (0.0%)	0.188
Dyslipidemia	8 (34.8%)	6 (31.6%)	0.826
Education level (years)	7.77 ± 4.89	5.32 ± 5.44	0.150
CDR	0.55 ± 0.21	0.53 ± 0.11	0.719
CDR-SB	1.84 ± 1.65	1.53 ± 1.06	0.786
MMSE	23.55 ± 3.69	21.52 ± 4.13	0.101
sGDS	4.73 ± 4.26	5.53 ± 4.05	0.446
NPI	6.36 ± 8.97	3.16 ± 5.15	0.503
Taking ChEIs	15 (65.2%)	7 (36.8%)	0.067
Taking SSRIs	6 (26.1%)	3 (15.8%)	0.418

Values are shown as mean ± standard deviation or number (%); DHI, dizziness handicap inventory; UCLA-DQ, The University of California Los Angeles Dizziness Questionnaire; CDR, the Clinical Dementia Rating; CDR-SB, Clinical Dementia Rating Sum of Boxes; MMSE, Mini-Mental State Examination; sGDS, SGDS = Short Geriatric Depression Scale; NPI, the Neuropsychiatric Inventory; ChEIs, Cholinesterase inhibitors; SSRIs, Selective serotonin reuptake inhibitors.

Table 2
Results of Neuropsychological battery

	Dizziness		p value
	No (DHI = 0) N=22	Yes (DHI > 0) N=19	
Digit span forward	5.14 ± 1.58	5.26 ± 2.08	0.774
Digit span backward	3.00 ± 1.41	2.42 ± 1.50	0.130
Korean-Boston naming test	34.45 ± 11.57	26.68 ± 11.92	0.036
RCFT copy	27.32 ± 9.33	22.32 ± 9.65	0.025
SVLT delayed recall	2.82 ± 2.48	1.89 ± 2.23	0.244
RCFT delayed recall	6.00 ± 6.79	3.63 ± 5.26	0.136
COWAT-animal	10.82 ± 4.08	8.95 ± 3.80	0.186
COWAT-phonemic	20.63 ± 9.33	7.59 ± 7.12	<0.001
Stroop test-color reading	64.42 ± 28.74	46.63 ± 34.50	0.171

Values are shown as mean ± standard deviation. RCFT, the Rey-complex figure test; SVLT, Seoul verbal learning test; COWAT, Controlled oral word association test.

P163: A MULTICENTER, RANDOMIZED TRIAL TO ASSESS EFFICACY OF THERAPEUTIC INTERVENTION PROGRAM FOR DEMENTIA CAREGIVERS (I-CARE). Jihye Hwang¹, Geon-Ha Kim², Hae-Ri Na³, Soo-Jin Cho⁴, Kyung-Ho Yu⁵, Do Hoon Kim⁶, Jae-Hong Lee⁷, Seong-Hye Choi⁸ ((1) Department of Neurology, Keimyung University School of Medicine; (2) Department of Neurology, Ewha Womans University School of Medicine; (3) Department of Neurology, Bobath Memorial Hospital; (4, 5, 6) Hallym University School of Medicine; (7) University of Ulsan College of Medicine, Department of Neurology, (8) Inha University School of Medicine)

Background and Purpose: Dementia is a progressive and degenerative disease that causes changes in brain tissue resulting in impaired memory, thinking, behavior, and a person's daily living. Dementia has devastating social, financial, physical, and psychological consequences not only for patients but also for their caregivers. The purpose of this study was to assess efficacy of therapeutic Intervention programs for decreasing caregiver burden in dementia caregiver (I-CARE). **Methods:** I-CARE is being conducted in 9 hospital-based dementia clinic. Total 38 caregiver of dementia patients were randomized into two groups: treatment group (n = 19) and control group (n = 19). The treatment group received 8-10 weeks of I-CARE intervention. It was composed of 4 sessions, one group education session delivered by a physician and 3 individual sessions, cover cognitive behavioral therapy (behavior management training and acceptance), stress-coping (self-compassion and acceptance) and stress-management (skill management), delivered by clinical psychologist trained in psychotherapy. **Results:** After 8-10 weeks of I-CARE intervention, the treatment group displayed a significant decrease of caregiver burden and depressive mood, while the control groups did not show significant changes. **Conclusions:** The results suggest that I-CARE was effective to reduce caregiver burden and distress by understanding dementia patients through this program. **Key Words:** caregiver of dementia patients, caregiver burden, therapeutic intervention

Theme: Health economics and clinical trials

P17: EFFECT OF PHYSICAL ACTIVITY ON THE PROGRESSION OF ALZHEIMER'S DISEASE: THE CREDOS STUDY. Seong Hye Choi¹, Jee Hyang Jeong², Eun-Joo Kim³, Kyung Won Park⁴, Bora Yoon⁵, Soo Jin Yoon⁶, Yang-Ki Minn⁷, Young Ju Suh⁸ ((1) Department of Neurology, Inha University School of Medicine, Incheon, South Korea; (2) Department of Neurology, Ewha Womans University School of Medicine, Seoul, South Korea; (3) Department of Neurology, Pusan National University School of Medicine, Busan, South Korea; (4) Department of Neurology, Dong-A Medical Center, Dong-A University College of Medicine, Busan, South Korea; (5) Department of Neurology, College of Medicine, Konyang University, Daejeon, South Korea; (6) Department of Neurology, Eulji University School of Medicine, Daejeon, South Korea; (7) Department of Neurology, Hallym University Kangnam Sacred Heart Hospital, Hallym University College of Medicine, Seoul, South Korea; (8) Department of Biomedical Sciences, Inha University School of Medicine, Incheon, South Korea)

Background: There is a lack of research on the effects of physical activity (PA) on the progression of Alzheimer's disease (AD). We aimed to investigate the relationship between recreational and nonrecreational PA levels and dementia progression over three years in AD patients. **Methods:** In the present study, 934 patients with mild to moderate AD were included. PA was evaluated using a questionnaire about recreational and non-recreational PA that was completed by the caregiver. The outcome measures were the Clinical Dementia Rating-Sum of Boxes (CDR-SB), the Seoul-Instrumental Activities of Daily Living (S-IADL), the Caregiver-Administered Neuropsychiatric Inventory (CGA-NPI), and a global composite score estimated by averaging the z scores of neuropsychological subtests. The patients were evaluated annually and received a maximum of three follow-up examinations. **Results:** Between-group differences compared with the no PA group in the change of CDR-SB scores were -0.421 (95% confidence interval = -0.827 ~ -0.015; p = 0.0442) for the low PA group (< 150 minutes per week of moderate intensity PA), -0.613 (-0.958 ~ -0.269; 0.0005) for the moderate PA group (150-750 minutes per week of moderate PA), and -1.195 (-1.630 ~ -0.761; < 0.0001) for the high PA group (> 750 minutes per week of moderate PA). As PA increased, there was a trend to slow the rate of increase in the CDR-SB (p < 0.0001), S-IADL (p < 0.0001), and CGA-NPI (p = 0.0005) scores. Conclusion: Higher levels of PA are associated with a slower progression of dementia, functional decline, and abnormal behaviors.

P40: THE SURVEY FOR CURRENT STATE AND DOGNITION OF ACTIVITIES OF DAILY LIVING IN KOREAN DEMENTIA PATIENTS. Kee Hyung Park¹, Chan-Nyoung Lee², Hojin Choi³ ((1)Department of Neurology, Gachon University, Gil Medical Center, Incheon, Korea; (2) Department of Neurology, Korea University College of Medicine, Seoul, Korea; (3) Department of Neurology, Hanyang University Guri Hospital, Guri, Korea)

Background: Disability of Activities of daily living (ADL) is the most important factor for care of dementia patients. So Korean Dementia Association investigated the current state and cognition of active daily living in Korean dementia patients at 2012. **Objectives:** We were again investigating what changed about that over six year period. **Methods:** A total of

100 subjects were interviewed. Structured open and closed questions about ADL for dementia were asked. They are main caregivers of dementia patients who working over 5hours per day. Assessments included age, sex, education level, economic status, severity of dementia patients, pattern of the care-giving, current state and cognition of ADL, and needs of the caregivers. **Results:** The cognition of ADL was higher than six years ago and this is still correlated with economic status. Increasing of care-giving time is the most stressful for caregivers, they frequently suffered from disability of outgoing and personal hygiene. Dementia patient's ADL disability causes serious economic losses, need of the caregivers about guide lines or education program was very high. **Conclusions:** Considering these results, we should design more detailed study about dementia patient's ADL disability and prepare guide line or program for it.

P58: YOUNG ONSET DISEASES CARE PATWAYS. PARCOURS DES MALADES ALZHEIMER ET APPARENTES JEUNES - PARMAAJ. Adeline Rollin-Sillaire^{1,2}, Brigitte Leprince³, Catherine Adnet-Bonte³, Laetitia Breuilh², Florence Pasquier^{1,2} ((1) Centre National de Référence des Malades Alzheimer Jeunes, Neurology Department, Centre Hospitalier Universitaire de Lille, France; (2) Excellence Laboratory DISTALZ, Inserm U1171, Univ Lille; (3) Meotis, Centre Hospitalier Universitaire de Lille, France)

Background: Young Onset Dementia (YOD) is a group of clinically, neuropathologically and genetically heterogeneous disorders, including Alzheimer's Disease (AD), Dementia with Lewy Bodies (DLB) and FrontoTemporal Lobar Degeneration (FTLD). It is a continuum of progressive neurodegenerative syndromes, beginning before 65 years of age. Because of their variable presentations, YOD are often misdiagnosed. Although the estimated prevalence in France is low, ie around 18 000 cases in comparison to the 860 000 late onset dementia cases, the burden and the consequences for patients, families and society are significant. Settled in the French area Hauts-de-France, the Lille Memory Resources and Research Centre (MRRC) was founded in 1991. Since 1995, it coordinates a network of 28 memory clinics, with the precious help of the Meotis team which is a hospital-private office network created in 2002. This network uses standardized procedures for diagnosis and follow-up and keeps up-to-date a database recording patients' medical profiles, allowing statistical analysis as well as clinical research feasibilities. The MRRC has been accredited as YOD National Reference Centre in 2009. Young onset AD patients followed in the MRRC have then been invited to participate in the longitudinal multidisciplinary cohort called "COMAJ" (COhorte Malades Alzheimer Jeunes). In parallel, non-AD YOD patients are asked for medicosocial data in the so called "pathway" medicosocial booklet. As YOD patients usually suffer from a delay before diagnosis, we wondered what are the key factors influencing this delay and how the medical and medicosocial pathways of these YOD patients are impacted. **Objectives:** This study (NCT03508024) aims to determine factors related to this delay before diagnosis for patients with young onset dementia (first symptoms before 60 years old) who live in the North of France. The following factors have been studied: current diagnosis, initial diagnosis, type of professionals that were met at the beginning of the symptoms, level of education, professional activity, professional consequences, familial situation, familial consequences, social consequences before

diagnosis, place of residence, place of care. **Methods:** The study consists in the analysis of YOD patients' medical and social data. For patients followed at the MRRC data will be collected from COMAJ and "Pathways" booklet databases. For patients followed outside the MRRC, data will be collected through interviews between an experienced nurse of the Meotis team and caregivers of YOD patients that have been diagnosed and/or are followed in memory clinics or in private practices. The caregiver is defined as a family member or friend who helps regularly by doing the necessary tasks so that the patient can keep as much autonomy as possible. As part of this study, patients will be considered: • Residing in the counties of Nord and Pas-de-Calais, • Whose diagnosis of Alzheimer's disease or related illness (FTLD, DLB) was announced, • Diagnosed after 2007, • Whose first symptoms appeared before the age of 60. As part of the survey, caregivers of patients meeting the above criteria and the following will be recruited: • Having consulted or being followed by private practices neurologists or in hospital memory consultations (excluding MRRC) of the counties of Nord and Pas-de-Calais, • Not followed at the MRRC (one-shot consultation is possible). Exclusion Criteria: • Aged under 18; • No social coverage; • Refusal to sign informed consent form. A total of 220 YOD patients is required, among which 97 are followed outside the MRRC. **Results:** Regulatory approvals have been obtained. Memory clinics and private practices specialists (neurologists and geriatricians) have been informed of this project, mainly by face-to-face interviews. To date, more than 60 potential participants have been referred to the Meotis nurse and 26 interviews have been done. In parallel, the COMAJ database has been completed regarding baseline data for AD patients and other YOD patients' data from the "Pathway" booklet have been collected. **Conclusion:** This project will help producing national guidelines regarding the medical and medicosocial care pathways. It also aims in heightening awareness of professionals regarding these YOD patients, in order to rise up their detection, diagnosis and care.

P164: DUTCH ONLINE REGISTRY FOR RECRUITMENT OF PARTICIPANTS FOR DEMENTIA STUDIES. Marissa D. Zwan¹, Derek Flenniken^{2,3}, Shannon Finley², Aaron Ulbricht^{2,3}, Rachel Nosheny^{2,3}, Wiesje M. van der Flier¹, Philip Scheltens¹, Diana Truran-Sacrey², Michael W. Weiner^{2,3}, Niels D. Prins¹ ((1) *Alzheimer Center & Department of Neurology, Neuroscience Campus Amsterdam, Amsterdam UMC, Amsterdam - the Netherlands;* (2) *Center for Imaging of Neurodegenerative Diseases, San Francisco Veteran's Administration Medical Center, San Francisco - USA;* (3) *UCSF Department of Radiology and Biomedical Imaging, San Francisco - USA*)

Background: Difficulty in participant recruitment is a significant barrier to clinical dementia studies. In collaboration with Brain Health Registry (BHR), the Dutch online registry Hersenonderzoek.nl was set up for online recruitment of participants in the Netherlands. Here we present preliminary results with respect to participant registration and enrollment in studies. **Objective:** To facilitate participant recruitment for clinical dementia studies in the Netherlands. **Methods:** Hersenonderzoek.nl consists of a dedicated website connected to an IT platform that allows data access and modification. This platform was provided as a Software as a Service solution by BHR and adjusted according to Dutch culture and language. Subjects interested in participating in brain research were reached via our dedicated Facebook recruitment

campaign targeted to (non-demented) individuals aged 50-70 years. The online registration process consists of a 5-minute minimal dataset (MDS) questionnaire including demographics, subjective complaints and medical history. Eligible subjects for recruiting studies were prescreened based on the MDS and invited to participate. Interested participants were contacted by the study investigator for further evaluation. **Results:** Since September 21st 2017, n=12335 participants have registered at Hersenonderzoek.nl. Table 1 provides an overview of registrants characteristics. To date, nine studies are currently recruiting or have recruited participants via our platform, of which three intervention studies and six observational studies. For these studies, prescreening identified 344 potential eligible participants. After further evaluation by the study investigator, 166 participants have successfully been enrolled in studies, resulting in a conversion rate of 0.48 (Table 2). **Conclusion:** Hersenonderzoek.nl is a growing cohort of individuals interested in participating in brain studies. Our preliminary findings demonstrate the feasibility to recruit study participants via Hersenonderzoek.nl for a variety of brain research studies with a high conversion rate. Following BHR, the launch of Hersenonderzoek.nl provides proof of concept for a scalable international online platform for participant recruitment. Next steps for Hersenonderzoek.nl are 1) to increase the number of participants enrolled in collaborating studies; and 2) increase the number of collaboration studies using the services of Hersenonderzoek.nl.

Table 1
Demographics of Hersenonderzoek.nl cohort

Total n	12115
Age	58.5±11.4
Female	72%
Education (Verhage)	4.7±1.0
Employed	54%
Retired	34%
Subjective memory complaints	29%
Diagnosis MCI or dementia	3%
MCI or dementia in 1st degree family	32%
(History of) cardiovascular disease	12%
(History of) neurological disease	5%
(History of) psychiatric diseases	20%

Data are presented as n, mean ± SD or %. MCI, Mild cognitive impairment

Table 2
Prescreening of participants for studies

Study	Type	Prescreened (n)	Enrolled (n)	Conversion
ABIDE-Delphi	Observational	139	54	0.39
BeHapp	Observational	42	22	0.52
EuroSCD	Observational	50	43	0.86
Catch-Cog	Observational	9	2	0.22
SCIENCe	Observational	16	4	0.25
90+	Observational	4	1	0.25
Excursion-VCI	Intervention	14	8	0.57
Generation1	Intervention	6	3	0.50
EPAD	Intervention	76	33	0.43
Total / mean		344	166	0.48

Theme: Epidemiology and clinical trials

P31: AWARENESS OF ALZHEIMER'S DEMENTIA AS THEIR OWN DISEASE IN ASIAN COUNTRIES. San Jung, YongSoo Shim, SangYun Kim (*Department of Neurology, Hallym University Medical Center, Kang Nam Sacred Heart Hospital, Seoul, Korea; Department of Neurology, College of Medicine, The Catholic University of Korea, Bucheon St. Mary's Hospital, Seoul, Korea; Department of Neurology, Seoul National University College of Medicine & Clinical Neuroscience Center, Seoul National University Bundang Hospital, Seoul, Korea*)

Background: This study was planned to investigate the differences of caregiving activity, burden, and insights in Asian caregivers of patients with Alzheimer's dementia (AD). Insights as their own disease and relating factors were compared in Asian countries. **Methods:** Insights whether the patients have a dementia were asked to caregivers and their patients and scores of Caregiver Activity Scale (CAS) and Zarit Burden Interview (ZBI) were questioned to caregivers participated in an Asian multi-national study. Additionally, basic demographic characteristics of caregivers and patients were analyzed. **Results:** Total 524 caregivers of AD patients, 101 from China, 10 from Hong Kong, 259 from Korea, 23 from the Philippines, 52 from Singapore, 6 from Thailand, and 73 from Taiwan, were participated. Caregivers' insight was 100% in the Philippines and Hong Kong, 83.33% in Thailand, 84.62% in Singapore, 76.71% in Taiwan, and less than 60% in China and Korea ($p < 0.001$). Patients' insight was 80.0% in Hong Kong, 78.26% in the Philippines, 66.67% in Thailand, 57.69% in Singapore, 52.78% in Taiwan, 35.71% in China, and 23.6% in Korea ($p < 0.001$). Patients acknowledge their own disease when they are female and younger, and when caregivers are offsprings, have longer educational duration, and have insights about their patients' disease. Caregivers acknowledge their patient's disease when patients are female and older, have more severe stages of dementia, and when caregivers are younger and offsprings, have longer educational duration, and have higher scores of ZBI. Caregivers' insights were reversely correlated with patients' insights. **Conclusions:** Insights of caregivers and patients were different in Asian countries, and accordingly caregiver burden and activity showed the cross-national

differences. In addition to language and cultural differences, recognition that the patients have an AD by public health education etc. could be helpful to decrease the caregiver burden and increase the insights.

P38: SUBJECTIVE MEMORY COMPLAINTS ARE RELATED TO THE SOCIAL PARTICIPATION AND LEISURE ACTIVITIES: TOYOAKE INTEGRATED CARE STUDY (TOICS). Hajime Takechi¹, Akira Tsuzuki², Komaki Matsumoto³, Hiroyuki Nishiyama⁴, Masatoshi Ogawa³, Yoshikiyo Kanada² ((1) *Department of Geriatrics and Cognitive Disorders, School of Medicine, Fujita Health University, Aichi, Japan;* (2) *Faculty of rehabilitation, School of Health Science, Fujita Health University, Aichi, Japan;* (3) *Department of community care, Toyoake city municipal] office, Aichi, Japan;* (4) *Gyosei Corporation, Tokyo, Japan*)

Background: Subjective memory complaints (SMC) has attracted attention in recent years in relation to the early stages of dementia. Numerous studies have been conducted on the relationship of SMC with actual cognitive function and depression. It is, however, not adequately clear how SMC has relevance to social participation activities, which would provide useful information for early intervention. **Objectives:** To clarify the association between SMC and social participation activities in large community sample. **Methods:** Mailing a questionnaire to 14850 older people aged 65 years or older residing in Toyoake City who did not receive the long-term care certification, as part of the TOyoake Integrated Care Study (TOICS) and receiving responses from 10740 people (response rate 72.4%). In this study, we targeted over 70 years of the respondents. Six thousand, six hundred eighty five people without any loss in the main items were included in the analysis. We conducted a questionnaire survey on age, sex, family composition, SMC, depression, physical activity, comorbidity, social participation and leisure activities. Social participation activities were examined for the presence and frequency of participation in four types of activities; volunteer, sports, hobby, and learning/cultivation. Statistical analysis by logistic regression was performed to see relationship of SMC and the activities. **Results:** For detecting SMC, three question were used. They are "I feel that I often forget things" (SMC-1), "There are times that other people point out my forgetfulness" (SMC-2), "sometimes I do not know the date" (SMC-3). In response to each question, responses of agreement were 45.3%, 13.3%, and 23.5%, respectively. All the responses were increasing with age. In relation to social activities and leisure activities, they were complicated by the responses to the two items of SMC-2 and SMC-3 after controlling for the age, gender, depression, comorbidity, physical activity (SMC-2: odds ratio 1.32, 95% CI 1.13-1.54, SMC-3: odds ratio 1.26, 95% CI 1.12-1.43). Although SMC-1 was not associated with participation of social activities and leisure activities in univariate analysis, it showed significance as a result of the multivariate analysis. It was shown that there was a significant increase in participation in social participation activities if they have positive response to SMC-1 (SMC-1: odds ratio 0.81, 95% CI 0.73-0.90). **Conclusions:** Although SMC was associated with participation in social activities and leisure activities, it was shown that there are differences depending on SMC question items. Since answers to SMC are thought to be related to decision making to participate in social participation activities appraising self-insight on cognitive function, the results of this research may call careful

differential use of SMC's wording. The results of this study would also be useful for considering preventive measures for older people with the risk of developing dementia.

P46: ALZHEIMER'S DISEASE DRUG DEVELOPMENT PIPELINE: 2018. Jeffrey Cummings¹, Garam Lee¹, Aaron Ritter¹, Kate Zhong² ((1) Cleveland Clinic Lou Ruvo Center for Brain Health, Las Vegas, NV, USA; (2) Global Alzheimer Platform, Washington, D.C., USA)

Background: This is our annual review of the Alzheimer's disease (AD) drug development pipeline providing a summary of the current state of progress in developing new therapies for AD. Treatments for AD are needed by the growing number of individuals with preclinical, prodromal, and dementia forms of AD. **Objective:** To provide insight into the AD drug development process. **Methods:** We assessed the agents in the AD pipeline as documented in clinicaltrials.gov for phase I, phase II, and phase III as of 1/30/2018. **Results:** There are 112 agents in the current AD treatment pipeline. There are 26 agents in 35 trials in phase III, 63 agents in 75 trials in phase II, and 23 agents in 25 trials in phase I. Sixty-three percent of the agents are disease-modifying therapies (DMTs), 22% are symptomatic cognitive enhancers, and 12% are symptomatic agents addressing neuropsychiatric and behavioral changes. Three percent have undisclosed mechanisms. Comparison to the 2017 pipeline shows that there are four new agents in phase III, 14 in phase II, and 8 in phase I. There are seven repurposed agents in phase III and 24 in phase II. Biomarkers are included in many drug development programs particularly those for DMTs. Amyloid biomarkers are used as entry criterion in 14 phase III DMT trials and 17 DMT trials in phase II. Twenty-one trials in phase II did not require biomarker confirmation for AD at trial entry. There were six prevention trials in phase III enrolling cognitively normal participants, two in phase II, and one in phase I. Most trials are sponsored by the biopharmaceutical industry, followed by academic medical centers with funding from NIH, industry or other entities. **Conclusion:** The Alzheimer's disease drug development pipeline is slightly larger in 2018 than in 2017. Trials increasingly include preclinical and prodromal populations. There is an increase in non-amyloid mechanisms of action in earlier phases of drug development. Biomarkers are increasingly used in AD drug development but are not uniformly employed for AD diagnosis confirmation.

P165: ASSOCIATION BETWEEN AMYLOID STATUS AND MULTIPLE CHRONIC DISEASES IN EUROPEAN PREVENTION OF ALZHEIMER'S DEMENTIA (EPAD): NETWORK AND CLUSTER ANALYSES. Lucy E Stirland¹, Tom C Russ^{1,2}, Graciela Muniz Terrera, ¹, Craig W Ritchie¹ ((1) Centre for Dementia Prevention, University of Edinburgh, Edinburgh, UK; (2) Alzheimer Scotland Dementia Research Centre, Edinburgh, UK)

Background: Multimorbidity, the co-occurrence of multiple chronic diseases within one individual, is increasing in prevalence. It is costly to health services and associated with poor quality of life. A recent Academy of Medical Sciences report highlighted its importance and identified research priorities. One of these priorities is to investigate the biological factors associated with the most common clusters of conditions. A 2012 Scottish population study found that 82% of people with dementia have two or more comorbid conditions. There is existing evidence of associations between multimorbidity and the development of cognitive impairment or dementia. One study examined overall multimorbidity with neuroimaging biomarkers and found no association between overall number of conditions and amyloid deposition. However, previous work has not studied patterns of comorbid conditions in detail. Network and cluster analyses are an increasingly important method of exploring the complexity of multimorbidity beyond simple disease counts. This work investigates associations between multimorbidity patterns and cerebrospinal fluid (CSF) amyloid, a biomarker of Alzheimer's disease. We will present novel results from the first wave of the European Prevention of Alzheimer's Dementia (EPAD) Longitudinal Cohort Study. **Objectives:** 1. To conduct separate network analyses of chronic condition occurrence in participants with and without significant CSF amyloid levels and compare these patterns. 2. To identify clusters of co-occurring chronic conditions among participants with multimorbidity and compare these clusters depending on amyloid status. **Methods:** EPAD is a large European multi-centre project developing a longitudinal cohort in readiness for clinical trials of dementia drugs. We will present cross-sectional data from its first phase. Participants are phenotyped in detail including serum and CSF measures, neuropsychological testing and structural and metabolic neuroimaging. A medical history is taken including asking participants whether they have any chronic medical conditions from a list of ten. This study will investigate patterns of occurrence of these conditions in relation to amyloid status. In keeping with other work on multimorbidity clusters, we will only include participants who have three or more conditions. We will generate an adjacency matrix of the chronic conditions before producing a network analysis graph. Nodes on the graph will be sized according to the relative prevalence of each condition, and edges between nodes will be thicker depending on frequency of that co-occurrence. This will demonstrate the prevalence of each condition in relation to the others, as well as how frequently they co-occur. We will test clustering methods of condition co-occurrence and select the most appropriate method based on modularity. The chosen method will allocate each participant into a cluster. We will generate a binary variable based on accepted significance levels for CSF amyloid and group the participants accordingly. We will then repeat the network and cluster analyses for each amyloid group, then compare the groups with each other, paying attention to the distribution of participants in each cluster. **Results:** Data

Figure 1

Agents in clinical trials for treatment of Alzheimer's disease in 2018 (from clinicaltrials.gov accessed 1/30/2018)

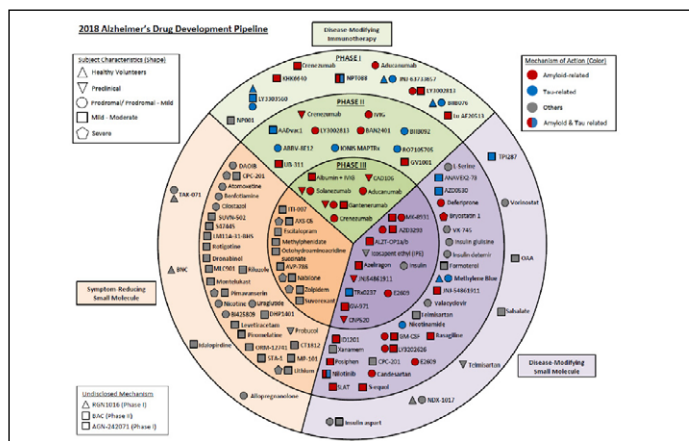

from over 500 participants in the first wave of EPAD will be released in June 2018, allowing us to conduct these analyses and present cutting-edge results at CTAD. **Conclusions:** This is the first study investigating the relationship between self-reported physical multimorbidity and a CSF biomarker for Alzheimer's disease. It will be a cross-sectional observation and will not elucidate causality, but will provide valuable information to further our understanding of Alzheimer's disease.

P166: CONCORD-AD: AN INTERNATIONAL NETWORK OF COHORTS FOR BETTER UNDERSTANDING ALZHEIMER'S DISEASE. Samantha C Burnham¹, Preciosa M Coloma², Teresa J. Christainson³, Jean-François Dartigues^{4,5}, Rachelle Doody⁶, Oskar Hansson⁷, Catherine Helmer^{4,8}, Joseph S Kass⁹, Colin L Masters¹⁰, Sebastian Palmqvist^{7,11}, Valory N Pavlik⁹, Ronald C. Petersen^{3,12}, Rosebud O. Roberts^{3,12}, Maria Vassilaki³, Barbara Schauble¹³, Mary Sano^{14,15} ((1) *eHealth, CSIRO Health & Biosecurity, Melbourne, Australia*; (2) *Product Development Personalised Health Care – Data Science, F. Hoffmann-La Roche Ltd., Basel, Switzerland*; (3) *Department of Neurology, Mayo Clinic, Rochester, MN, USA*; (4) *Bordeaux University, Bordeaux, France*; (5) *INSERM, ISPED, Centre INSERM U897-Epidémiologie-Biostatistique, Bordeaux, France*; (6) *F. Hoffmann-La Roche Ltd, Basel, Switzerland*; (7) *Clinical Memory Research Unit, Lund University, Malmö, Sweden*; (8) *INSERM U897, BORDEAUX, France*; (9) *Baylor College of Medicine, Houston, TX, USA*; (10) *The Florey Institute of Neuroscience and Mental Health, Parkville, Australia*; (11) *Department of Neurology, Skåne University Hospital, Lund, Sweden*; (12) *Department of Health Sciences Research, Division of Epidemiology, Mayo Clinic, Rochester, MN, USA*; (13) *Product Development Medical Affairs, F. Hoffmann-La Roche Ltd., Basel, Switzerland*; (14) *Department of Psychiatry, Alzheimer's Disease Research Center, Icahn School of Medicine at Mount Sinai, New York, NY, USA*; (15) *James J. Peters VA Medical Center, Bronx, NY, USA*)

Background: Without intervention Alzheimer's Disease (AD) will devastate public health resources and overwhelm current healthcare infrastructure on a global scale. To mitigate the impact of AD on society, novel disease modifying therapies are needed. One approach is to pool global resources and expertise to generate insights that can improve disease understanding and inform design of therapeutic trials at all stages of the disease. It is within this context that CONCORD-AD (Connecting Cohorts to Diminish Alzheimer's Disease) was created with the mission to foster scientific exchange, generate insights and contribute to the evolving clinical science in AD. **Objectives:** To present an overview and summary characteristics of the CONCORD-AD network of cohorts. **Methods:** The current CONCORD-AD network includes seven longitudinal cohorts across Australia, Europe and North America representing data from >20,000 individuals across the disease spectrum - from cognitively unimpaired to AD dementia as well as other dementias. The network includes the Australian Biomarker and Lifestyle Study of Aging (AIBL), AMI cohort of elderly farmers, Baylor Alzheimer's Disease and Memory Disorders Center, Swedish BioFINDER Study, Mayo Clinic Study of Aging (MCSA), Personnes Agées QUID (PAQUID) and the 3-City (3C) Study-Bordeaux. Participants in these studies have been extensively characterized both clinically and biologically and have follow-up evaluations of up to 22 years. Evaluation of the STROBE guidelines and all available data from each cohort allowed a recommendation to be made for the 'core dataset' essential to facilitate combined analyses. Further, 'core data' from six (AIBL,

Baylor, BioFINDER, MCSA, PAQUID and 3C) of the seven CONCORD-AD cohorts were evaluated and compared to assess the heterogeneity across the cohorts. Quantitative comparisons were made between the overall cohorts as well as within their sub-cohorts that aligned with the clinical classifications of Cognitively Normal Elderly Control (NC); Mild Cognitively Impaired (MCI) and dementia due to AD. **Results:** Core data, essential to facilitate combined analysis, were identified that belonged to one of three study aspects: (1) qualitative study information aligned to STROBE guidelines (study rationale, objectives, setting, participant recruitment, inclusion/exclusion criteria, clinical classification criteria as well as limitations and generalisability); (2) quantitative demographic information (numbers of participants, follow-up & attrition, age, gender, years of education and APOE ϵ 4 carrier status); (3) Core biomarker, clinical and cognitive data which identified 9 overlapping markers of interest (amyloid PET, hippocampal volume, CSF A β 42, tTau and pTau, CDR Sum of Boxes, MMSE, ADAS-Cog delayed recall and NPI-Q). The six cohorts considered focussed on evaluating aging and incorporated AD participants with study objectives of prospective database creation and early disease detection through biomarker identification. Recruitment strategies were also varied with the Baylor study solely recruiting through memory clinics, AIBL & BioFINDER recruiting through memory clinics and soliciting age-matched normal elderly controls whereas participants from MCSA, PAQUID, 3C (as well as AMI) were recruited as population-based cohorts. As a consequence of the varied study designs, recruitment protocols and inclusion/exclusion criteria, there were differences in the demographic make-up of the participants enrolled in each of these studies (shown in Table 1). For example, the prevalence of APOE ϵ 4 carriers ranged from 20-46%. In addition, it appeared that there were similar performances on MMSE for NC in the AIBL, Baylor and BioFINDER cohorts, whereas participants in the MCSA, 3C and particularly PAQUID cohorts performed slightly worse and had a much wider range of scores (see Figure 1). This variability primarily reflects the differences between the memory clinic-based and population-based cohorts. **Conclusions:** Differences were observed in the biological, clinical and cognitive markers of interest among the core cohorts evaluated. This was not unexpected given the differences in study population make-up between the cohorts. The collaboration model in CONCORD-AD involves sharing of independently conducted analyses addressing key questions about disease progression, biomarker-clinical correlations and patient-relevant outcomes. This model facilitates evaluations into the impact of disease heterogeneity (e.g. geographic and cultural variations, differences in healthcare systems, study inclusion/exclusion criteria) on critical scientific questions. Although each cohort was established differently, the opportunity to combine data from seven cohorts provides a unique resource to replicate findings, explore causes of heterogeneity, increase sample size/power, and leverage disease area expertise across different settings. Expansion of the network to include other well-characterized cohorts and eminent investigators would further strengthen the potential to better understand, and eventually conquer, AD.

Table 1
Demographic information across six cohorts

	AIBL	Baylor	BioFINDER	MCSA	PAQUID	3C
N	1807	3181	1267	4696	3777	2104
Total Follow-up Time in years [median, (range)]	4.5 (0-7.5)	1.5 (0-17.6)	NA	4.1 (0-12.8)	5.8 (0-13.3)	10.8 (0-11.9)
Attrition Rate per Year (%)	8.7	5.1	NA	7.5	NA	NA
Aged over 70 [N (%)]	1001 (55)	2158 (68)	778 (61)	3326 (71)	2677 (71)	1636 (78)
Male [N (%)]	768 (43)	1240 (39)	641 (51)	2388 (51)	1577 (42)	816 (39)
Over 12 Years of Education [N (%)]	895 (49)	1883 (59)	276 (22)	3009 (64)	387 (10)	779/2099 (37)
APOE ε4 Carrier [N (%)]	547 (30)	1427 (46)	507 (39)	1299 (28)	151 (23)	365/1866 (20)

Figure 1

MMSE performance among NC compared across six cohorts

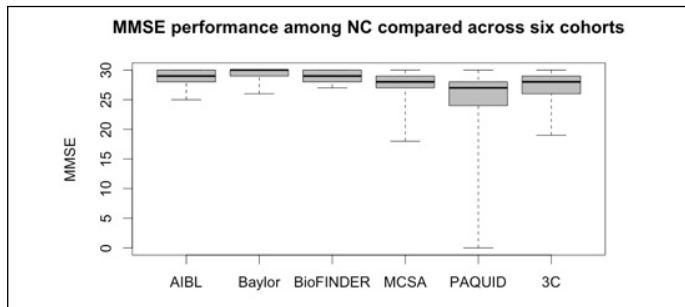

P167: COGNITIVE AND BRAIN STRUCTURAL CORRELATES OF INSOMNIA SYMPTOMS IN MIDDLE-AGED HEALTHY ADULTS.

Oriol Grau-Rivera¹, Juan Domingo Gispert^{1,2}, Grégory Operto¹, Carles Falcóna¹, Raffaele Cacciaglia¹, Gonzalo Sánchez-Benavides¹, Anna Bugulal¹, Nina Gramunt^{1,3}, Gemma Salvadó¹, Marc Suárez-Calvet¹, Carolina Minguillón¹, Karine Fauria¹, José Luis Molinuevo^{1,3,4} ((1) *Barcelonaβeta Brain Research Center, Catalonia, Spain*; (2) *Centro de Investigación Biomédica en Red de Bioingeniería, Biomateriales y Nanomedicina (CIBER-BBN), Zaragoza, Spain*; (3) *CIBER Fragilidad y Envejecimiento Saludable (CIBERFES), Madrid, Spain*; (4) *Institut d'Investigacions Biomèdiques August Pi i Sunyer (IDIBAPS), Barcelona, Catalonia, Spain*)

Background: Increasing evidence supports an association between insomnia and cognitive impairment. More specifically, a bidirectional relationship between Alzheimer's disease (AD) and insomnia has been reported, in which sleep deprivation may increase the rate of amyloid accumulation and AD may alter sleep-wake cycle regulation. Evaluating the impact of sleep deprivation on cognitive performance and neuroimaging measures may be relevant for the future design of AD prevention strategies and clinical trials. However, studies evaluating structural changes related to insomnia have yielded inconsistent results, mainly due to differences in the neuroimaging methods and small sample sizes. Our objective was to study the cognitive and imaging structural characteristics of cognitively healthy elders with increased risk for AD with insomnia symptoms. **Methods:** 1225 cognitively unimpaired participants (mean age 55 years, range 44-74; 58% female; 33% APOE-ε4 carriers) from the ALFA study were included who had completed a cognitive battery and a structured insomnia questionnaire (World Health organization's World Mental Health Survey Initiative version of the Composite International Diagnostic Interview). Episodic memory was assessed with the Memory Binding Test (MBT) and other cognitive functions

by means of the coding, digit span, matrix reasoning, visual puzzles and similarities subtest of the WAIS-IV battery. Participants were categorized as having insomnia if they reported (1) difficulty initiating sleep, (2) difficulty maintaining sleep or (3) early morning awakening, or as not having insomnia otherwise. T1-weighted MRI scans were acquired in a subsample of 349 participants (mean age 57 years, range 45-74; 55% female; 49% APOE-ε4 carriers). Voxel-based morphometry analysis (VBM) was performed to assess between-group differences in grey matter (GM) volume, using a voxel threshold of p<0.005 uncorrected for multiple comparisons on the whole-brain level and a cluster threshold of 100 voxels. Associations between cognitive performance and insomnia were evaluated with multiple linear regression using a p<0.05 threshold for statistical significance. All statistical analyses were adjusted by age, gender, education, APOE status, anxiety and depression levels, body mass index and cardiovascular risk factors. Neuroimage analyses were also adjusted by total intracranial volume. **Results:** Participants with insomnia (n=374) performed significantly worse than those without sleep complaints (n=851) in memory (p<0.01 in all variables of the MBT) and executive function test (p<0.04 in WAIS-IV coding and digit span subtest). VBM analysis showed lower GM volume in subjects with insomnia (n=121) in left orbitofrontal cortex, right precuneus, left temporal pole, left hippocampus, bilateral posterior cingulate cortex / retrosplenial cortex, bilateral middle cingulum and bilateral thalamus. Higher volume was observed in subjects with insomnia in bilateral caudate, left orbitofrontal cortex and right posterior cingulate. Results were confirmed by calculating between-group differences using Freesurfer-derived ROIs. **Conclusion:** The presence of insomnia symptoms is associated with worse cognitive performance and brain structural changes in middle-aged cognitively unimpaired adults at risk for AD. Reduced volume in areas known to be early involved in AD (precuneus, temporal pole, cingulate cortex and hippocampus) support a potential early association between insomnia and AD physiopathology. In line with this, findings of higher GM volume in bilateral caudate are in keeping with previous observations in subjects with preclinical AD.

P168: A PHASE II RANDOMIZED CLINICAL TRIAL OF HIGH-DOSE VERSUS STANDARD-DOSE VITAMIN D3 IN AN ETHNICALLY DIVERSE SAMPLE OF OLDER ADULTS.

John Olichney¹, Charlie DeCarli¹, Joshua W Miller², David Johnson¹, Sarah Tomaszewski-Farias¹, Bruce Hammock³, Brittany Dugger⁴, Lee-Way Jin⁴, Mary McPhail-Ciufo¹, Robert Soohoo⁵, Dan Mungas¹, Danielle Harvey⁶ ((1) *Neurology Department, University of California Davis, Sacramento, CA, USA*; (2) *Department of Nutritional Sciences, Rutgers, The State University of New Jersey, New Brunswick, NJ*; (3) *Department of Entomology & Comprehensive Cancer Center, University of California Davis, Davis, CA, USA*; (4) *Pathology Department, University of California Davis, Sacramento, CA, USA*; (5) *Psychology Department, University of California Davis, Davis, CA, USA*; (6) *Department of Public Health Sciences, University of California Davis, Davis, CA, USA*)

Background: There is mounting evidence that low vitamin D blood levels are associated with increased risk of dementia and Alzheimer's disease (AD). There are several mechanisms by which low vitamin D status may promote AD pathology, including reduced β-amyloid (Aβ) clearance, dysregulation of calcium influx, and glutamate-mediated neurotoxicity.

Vitamin D interacts with receptors in the hippocampus and many other brain regions, and has established antioxidant and anti-inflammatory effects. Recent neuroimaging studies have found that low vitamin D levels are associated with increased periventricular white matter disease, reduced white matter volume, and enlarged ventricles. Vitamin D deficiency may also have a toxic effect on brain function independent of A β metabolism. Preliminary studies of serum vitamin D levels in a diverse multi-ethnic cohort (n=382) of the UC Davis Alzheimer's Disease Center found a high prevalence of low vitamin D status (61% with levels <20 ng/ml, nearly 70% of minority participants), which was associated with faster rates of decline in executive function and episodic memory (JW Miller et al 2015, JAMA Neurology). **Objectives:** This Phase II randomized clinical trial aims to test if supplementation with high dose oral vitamin D3 (i.e. 4,000 IU daily) will successfully correct vitamin D insufficiency, compared to treatment with standard (RDA) dose vitamin D3 (600 IU daily) in a diverse community-based elderly cohort. The effect of high-dose vs. standard-dose vitamin D on altering cognitive trajectories will also be assessed and data will be expected to be used in designing a potentially definitive Phase III trial in elderly groups at risk for dementia. The Specific Aims are: 1) to compare the effectiveness of high-dose versus standard-dose oral vitamin D in correcting low vitamin D status in a diverse community-based cohort. 2) To assess the effect of high-dose vs. standard-dose vitamin D on altering cognitive trajectories (primary outcome: SENAS-executive function; secondary outcome: ADAS-Cog), and gather preliminary data relevant to the design of a Phase III trial in elderly at-risk groups. 3) To compare the effects of high-dose vitamin D versus standard-dose vitamin D on key brain and blood biomarkers relevant to healthy brain aging. The main outcome measures for Aim 3 are MRI atrophy rates (total gray + white matter volume, hippocampal volume), blood inflammatory markers (hs-CRP, IL-6, IL-10, TNF-alpha), and blood and urine markers of oxidative stress (e.g. isoprostane). **Methods:** A total of 180 elderly persons with longitudinal biomarkers, neuropsychological testing and brain MRI scans will be enrolled, with 150 (~50 with MCI, 50 with mild AD, and 50 with no cognitive impairment) expected to complete the 3½-year study. One-half of each diagnostic group will be randomized to treatment with high-dose vitamin D3 (4,000 IU daily) or to standard dose vitamin D (600 IU daily). Longitudinal MRI analyses will provide an estimate of the treatment effect size on brain atrophy rate. Vitamin D receptor genotype polymorphisms and their impact on response to oral supplementation will also be examined. Dietary vitamin D intake will be assessed by a brief, vitamin D-specific food frequency questionnaire and controlled for as a potential confounding factor. **Results:** We expect the first participants to enter this clinical trial in September or October of 2018. Preliminary data and experience with screening and trial initiation will be shared at the CTAD presentation. **Conclusions:** If vitamin D supplementation improves cognitive outcome, this could have a large impact on the public health, since low vitamin D status is a common, readily treatable condition which may provide a novel window to prevent dementia and AD. Furthermore, the higher prevalence of AD and dementia in African Americans and Latinos could be partially attributable to vitamin D insufficiency.

Theme: Animal model and clinical trials

P102: CONCUSSIVE HEAD INJURY EXACERBATES ALZHEIMER'S DISEASE BRAIN PATHOLOGY. SUPERIOR NEUROPROTECTION BY CO-ADMINISTRATION OF TIO2 NANOWIRED CEREBROLYSIN TOGETHER WITH ANTIBODIES TO NEURONAL NITRIC OXIDE SYNTHASE AND MESENCHYMAL STEM CELLS. Hari Shanker Sharma¹, José V Lafuente², Dafin F Muresanu³, Rudy J Castellani⁴, Mark A Smith⁵, Ala Nozari⁶, Ranjana Patnaik⁷, Z Ryan Tian⁸, Asya Ozkizilcik⁹, Stephen D Skaper¹⁰, Herbert Mössler¹¹, Aruna Sharma¹ ((1) *International Experimental CNS Injury & Repair (IECNISIR), Laboratory of Cerebrovascular Research, Dept. of Surgical Sciences, Anesthesiology & Intensive Care Medicine, Uppsala University Hospital, Uppsala University, Uppsala, Sweden;* (2) *Dept of Neurosciences, University of Basque Country, Bilbao, Spain;* (3) *Dept. Clinical Neurosciences, University of Medicine & Pharmacy, Cluj-Napoca, Romania;* a "RoNeuro" *Institute for Neurological Research and Diagnostic, Cluj-Napoca, Romania;* (4) *University of Maryland, Dept. of Pathology, Baltimore, MD, USA;* (5) *Case Western Reserve Medical University, Dept. of Pathology, Cleveland, OH, USA;* (6) *Anesthesiology, Massachusetts General Hospital, Harvard University, Boston MA, USA;* (7) *School of Biomedical Engineering, Dept. of Biomaterials, Indian Institute of technology, Banaras Hindu University, Varanasi, India;* (8) *Dept. Chemistry & Biochemistry &;* (9) *Biomedical Engineering, University of Arkansas, Fayetteville, AR, USA;* (10) *Department of Pharmacology and Anesthesiology, University of Padua, Faculty of Medicine, Padua, Italy;* (11) *Ever NeuroPharma, Oberburgau, Austria*)

Background: Alzheimer's disease (AD) inflicts over 40 millions people aged 65 and older Worldwide and roughly 5 million Americans are living with the disease that involves huge burden on the society and families as well. In addition, AD is quite frequent in Military personnel because of possible mild traumatic brain injury or concussive head injury that may exacerbate AD induced brain pathology. Thus, exploration of novel therapeutic measures is needed to contain the disease and improve the quality of life of the victims. Increasing evidences suggest that oxidative stress is one of the key factors in causing AD induced brain pathologies. Brain injury alone induces upregulation of several oxidative stress parameters and thus, a combination of brain injury and AD could lead to devastating brain damage. Few studies in AD also suggest a key role of nitric oxide (NO) in enhancing amyloid beta peptide (A β P) induced neurotoxicity. NO is synthesized by the endogenous enzyme nitric oxide synthase (NOS) that occurs in 3-isoforms, namely neuronal NOS (nNOS), inducible NOS (iNOS) and endothelial NO (eNOS). Thus, blockade of NOS activity appears to be beneficial AD, a feature that requires additional investigation. Moreover, several lines of evidences suggests that mesenchymal stem cells (MSCs) could be possible potential therapeutic agents in AD in formation of new neurons and making novel synaptic connections. Also, MSCs enhance neurotrophic factors within the brain that could help in achieving neuroregeneration and functional improvement in AD. This suggests that AD pathology is complex. Thus, it would be interesting to explore co-administration of key agents that could block NO synthesis, induce regeneration and create new neuronal connections together with exogenous supplement of several neurotrophic factors to treat AD successfully. Thus, in this investigation, we used antibodies to nNOS to reduce toxicity together with MSCs to improve new neuronal

connections and supplied exogenous neurotrophic factors using Cerebrolysin. Cerebrolysin is a balanced composition of several neurotrophic factors and active peptide fragments that could induce neuroplasticity, neuroregeneration and neutralize A β P neurotoxicity. Since nanodelivery of compounds results in higher bioavailability for long time, we used TiO₂-nanowired delivery of these agents together to induce superior neuroprotection in AD following concussive head injury (CHI). **Methods:** AD like pathology was produced in rats by administering A β P (1-40) intraventricularly (i.c.v.) in the left lateral ventricle (250 ng/10 μ l) once daily for 4 weeks in normal or CHI rats. The CHI was induced in anaesthetized rats by dropping a weight of 114.6 g on the exposed right parietal skull from a 20 cm height thorough a guide tube. This would cause an impact of 0.224 N on the skull surface. Control rats received saline. In separate group of rats either TiO₂ nanowired monoclonal antibodies of neuronal nitric oxide synthase (NWnNOS abs, 1:20, 50 μ l) together with nanowired MSCs (NWMSCs 1 million active cells) and nanowired cerebrolysin (NWCBL 50 μ l) were administered (i.c.v.) once daily 3 weeks after the 1st A β P administration and continued for 1 week. After 30 days of the 1st A β P infusion, the rats were examined for BBB breakdown, edema, neuronal, glial injuries and A β P deposits in their brain. **Results:** CHI results in 2- to 4-fold exacerbation of AD induced brain pathology. Our results showed that co-administration of NWnNOS, NWMSCs and NWCBL was able to significantly reduce A β P deposits in the brain after CHI along with neuronal damage and glial activation. Interestingly, the breakdown of the BBB to Evans blue albumin and radioiodine in cortex, hippocampus, hypothalamus and cerebellum was significantly reduced in drug treated group as compared to control. Combination of these three agents showed superior effects in reducing brain pathology in AD as compared to any combination of 2 agents or all agents alone. These combinations of 3 agents were also able to reduce A β P deposit in the brain and improved behavioral functions on Rota Rod treadmill and inclined angle platform as well as hidden platform search under water. This suggests that blockade of nNOS together with supplement of exogenous neurotrophic factors and MSCs are capable to reduce AD induced brain pathology. Interestingly, when these 3 agents were delivered without using nanotechnology, there neuroprotective effects were much diminished in AD with CHI. However; these agents were able to thwart AD induced brain pathology in normal animals. This suggests that TiO₂-nanowired delivery of these agents are needed to induce superior neuroprotection in AD brain pathology following CHI. Our results further showed a close correspondence with reduction in A β P deposits in the brain and neuronal damage and glial activation following AD in CHI. Also, breakdown of the BBB and brain edema formation was absent in AD with CHI in nanowired delivery of these 3 agents as compared to either agents alone. Thus, a combination of NWnNOS, NWMSCs and NWCBL is needed to induce superior neuroprotective effects in reducing brain pathology in AD after CHI. **Conclusion:** Taken together, our observations are the first to show that blockade nNOS activity, enhancement of neuronal connection with MSCs and exogenous supplement of neurotrophic factors by cerebrolysin potentiate the neuroprotective effects in AD brain pathology following CHI, not reported earlier. *Supported by grants from the Air Force Office of Scientific Research (EOARD, London, UK), and Air Force Material Command, USAF, under grant number FA8655-05-1-3065; supported by Grants from the Alzheimer's

Association (IIRG-09- 132087), the National Institutes of Health (R01 AG028679) and the Dr. Robert M. Kohrman Memorial Fund (MAS, RJC); Swedish Medical Research Council (Nr 2710-HSS), Göran Gustafsson Foundation, Stockholm, Sweden (HSS), Astra Zeneca, Mölndal, Sweden (HSS/AS), The University Grants Commission, New Delhi, India (HSS/AS), Ministry of Science & Technology, Govt. of India (HSS/AS), Indian Medical Research Council, New Delhi, India (HSS/AS) and India-EU Co-operation Program (RP/AS/HSS) and IT 794/13 (JVL), Government of Basque Country and UFI 11/32 (JVL) University of Basque Country, Spain, & Society for Neuroprotection and Neuroplasticity (SSNN), Romania.

P103: SLEEP DEPRIVATION AGGRAVATES ALZHEIMER'S DISEASE BRAIN PATHOLOGY. ENHANCED NEUROPROTECTION BY NANOWIRED DELIVERY OF CEREBROLYSIN WITH ALPHA MELANOCYTE STIMULATING HORMONE AND ANTIBODIES TO ALPHA-SYNUCLEIN. Hari Shanker Sharma¹, José V Lafuente², Dafin F Muresanu³, Rudy J Castellani⁴, Mark A Smith⁵, Ala Nozari⁶, Ranjana Patnaik⁷, Z Ryan Tian⁸, Asya Ozkizilcik⁹, Stephen D Skaper¹⁰, Herbert Mössler¹¹, Aruna Sharma¹ ((1) *International Experimental CNS Injury & Repair (IECNISIR), Laboratory of Cerebrovascular Research, Dept. of Surgical Sciences, Anesthesiology & Intensive Care Medicine, Uppsala University Hospital, Uppsala University, Uppsala, Sweden;* (2) *Dept of Neurosciences, University of Basque Country, Bilbao, Spain;* (3) *Dept. Clinical Neurosciences, University of Medicine & Pharmacy, Cluj-Napoca, Romania;* a "RoNeuro" *Institute for Neurological Research and Diagnostic, Cluj-Napoca, Romania;* (4) *University of Maryland, Dept. of Pathology, Baltimore, MD, USA;* (5) *Case Western Reserve Medical University, Dept. of Pathology, Cleveland, OH, USA;* (6) *Anesthesiology, Massachusetts General Hospital, Harvard University, Boston MA, USA;* (7) *School of Biomedical Engineering, Dept. of Biomaterials, Indian Institute of technology, Banaras Hindu University, Varanasi, India;* (8) *Dept. Chemistry & Biochemistry &* (9) *Biomedical Engineering, University of Arkansas, Fayetteville, AR, USA;* (10) *Department of Pharmacology and Anesthesiology, University of Padua, Faculty of Medicine, Padua, Italy;* (11) *Ever NeuroPharma, Oberburgau, Austria*)

Background: Military personnel are often subjected to sleep deprivation (SD) for more than 24 to 48 h during combat operation or vigilance duty. This results in mental dysfunction and generates oxidative stress in the brain causing structural and functional abnormalities in the brain. Apart from SD military personnel are exposed to a variety of mental and physical stress leading to generation of oxidative stress leading to alterations in the cellular and molecular machinery of the central nervous system (CNS). As a result, military personnel are quite prone in developing Alzheimer's disease (AD). Generation of oxidative stress could induce breakdown of the blood-brain barrier (BBB) to protein molecules from the blood compartment that in turn results in vasogenic brain edema formation and cell injury. Amyloid- β peptide (A β P) responsible for AD and alpha-synuclein (α -Syn) responsible for Parkinson's disease (PD) are both present in the plasma of healthy persons and are supposed to increase by oxidative stress. There are reasons to believe that both α -Syn and A β P are working together for brain pathology in AD. Thus, It is quite likely that blood levels of A β P and α -Syn may enter into the brain after BBB breakdown due to severe stress resulting in exacerbation of AD induced brain pathology in military personnel. Since

sleep patterns are modulated by alpha-melanocyte stimulating hormone (α -MSH), it is interesting to explore therapeutic effects of this peptide in AD with SD cases. In this investigation, we explored the role of nanowired delivery of a multimodal antioxidant drug cerebrolysin (EverNeuroPharma, Austria) together with α -MSH and antibodies to α -Syn in A β P infusion model of AD in SD. **Methods:** Experiments were carried out on Male Sprague Dawley rats (250-300 g, Age 30 to 35 weeks). AD like symptoms was produced by intraventricularly (i.c.v.) administration of A β P (1-40) in the left lateral ventricle in a dose of 250 ng/10 μ l once daily for 4 weeks in normal and SD rats. Rats were subjected to SD using inverted flower-pot model surrounded with water at 30°C for 48 h. Control group received physiological saline (0.9% NaCl) instead of A β P infusion. After 30 days of the 1st A β P or saline infusion, the rats were examined for BBB disturbances to endogenous/exogenous protein tracers, brain edema formation, A β P deposits and brain pathology comprising, neuronal, glial and axonal changes using standard procedures. In addition, separate group of rats received TiO₂-nanowired cerebrolysin (NWCBL 25 μ l, i.c.v.) together with NW α -MSH (50 μ g in 20 μ l) and NW-antibodies (abs) to α -Syn (1:20, 30 μ l) under identical conditions after 1 week of A β P infusion daily for 2 weeks. In all these cerebrolysin treated animals with or without nanodelivery, brain pathology and behavioral functions were analyzed using standard protocol. Furthermore, in these AD rats untreated or treated with NWCBL, α -MSH and α -Syn abs, CSF collected from cisterna magna and brain tissues obtained from cerebral cortex, hippocampus and cerebellum was measured for α -Syn and A β P concentrations using commercial ELISA kit protocol. **Results:** Our observations showed that SD significantly enhanced AD like symptoms following A β P infusion. Thus, there was 1.5 to 2.8-fold higher A β P deposits in the cortex and in hippocampus. Neuronal damages and cell death, activation of astrocytes as seen using glial fibrillary acidic protein (GFAP), loss of myelin basic protein (MBP) and exudation of albumin in the brain were 2 to 3-fold higher in SD after A β P infusion. Breakdown of the BBB to Evans blue albumin or radioiodine ([¹³¹I]-I) and edema formation was 150 to 22% higher in several SD brain areas following A β P infusion. The behavioral disturbances on Rota Rod performances and inclined plane angle tests were markedly deteriorated by 50 to 130 % in SD after A β P infusion along with the ability to retrieve platform in water maze tests as compared to A β P in control group. Our results further showed a 150 to 190 % increase in α -Syn and A β P in CSF and 286 to 367% elevation in the cortex, hippocampus and cerebellum from control group (α -Syn 2.51 \pm 0.23 pg/ μ l, SD 3.23 \pm 0.87 pg/ μ l; Brain 5.13 \pm 0.88 ng/ μ g SD 9.34 \pm 1.01 ng/ μ g) in A β P infused rats as compared to SD+ A β P group. Likewise, A β P was elevated 1.5 fold in CSF and 2-fold in the AD brain in SD from control (CSF 0.34 \pm 0.08 ng/ml, SD 0.65 \pm 0.08 ng/ml; Brain 0.56 \pm 0.03 ng/mg; SD 1.34 \pm 0.11 ng/mg). NWCBL together with α -MSH and α -Syn abs administration significantly reduced the elevation of both α -Syn and A β P in AD after SD and thwarted brain pathology. Interestingly, the combined treatment of NWCBL with α -MSH and α -Syn abs resulted in profound superior reduction in α -Syn and A β P levels following SD in AD brain pathology as compared these compounds given alone under identical condition. The BBB breakdown, edema formation and brain pathology as well as behavioural dysfunction in SD were also reduced significantly by the combined treatment of NWCBL with α -MSH and α -Syn abs after A β P infusion. **Conclusions:** These results are the first to indicate that SD

exacerbates AD brain pathology and the combined treatment of NWCBL with α -MSH and α -Syn abs has superior neuroprotective effects in reducing AD induced brain pathology in SD, not reported earlier. *Supported by grants from the Air Force Office of Scientific Research (EOARD, London, UK), and Air Force Material Command, USAF, under grant number FA8655-05-1-3065; supported by Grants from the Alzheimer's Association (IIRG-09- 132087), the National Institutes of Health (R01 AG028679) and the Dr. Robert M. Kohrman Memorial Fund (MAS, RJC); Swedish Medical Research Council (Nr 2710-HSS), Göran Gustafsson Foundation, Stockholm, Sweden (HSS), Astra Zeneca, Mölndal, Sweden (HSS/AS), The University Grants Commission, New Delhi, India (HSS/AS), Ministry of Science & Technology, Govt. of India (HSS/AS), Indian Medical Research Council, New Delhi, India (HSS/AS) and India-EU Co-operation Program (RP/AS/HSS) and IT 794/13 (JVL), Government of Basque Country and UFI 11/32 (JVL) University of Basque Country, Spain, & Society for Neuroprotection and Neuroplasticity (SSNN), Romania.

P104: THE EFFECT OF CRENEZUMAB ON BETA-AMYLOID TOXICITY-INDUCED SYNAPSE LOSS, NEUROFIBRILLARY TANGLES AND CELL DEATH IN HUMAN NEURONS IN VITRO. Ben Chih, Reina A. Bassil, Shirley Ng, Maureen Beresini (*Genentech, Inc., South San Francisco, CA, USA*)

Background: The two key human brain pathological hallmarks of Alzheimer's disease (AD) are beta-amyloid (A β) plaques and tau fibrillary tangles. A β accumulation has been proposed to lie upstream of tau aggregation and tangle formation. Unfortunately, transgenic mouse models of AD have failed to faithfully recapitulate these two pathologies together, making it challenging to test the impact of A β -targeting therapeutics on reducing tau pathology. Human induced pluripotent stem cell (iPSC)-derived neurons have the potential to fill the knowledge gap between preclinical mouse models and human patients with AD. We generated a human iPSC neuronal model that faithfully recapitulates human AD pathologies and may enable better predictions of translational outcomes with therapeutic drug candidates. Crenezumab is a monoclonal anti-A β immunoglobulin G4 (IgG4) antibody currently in development for the treatment of AD. Crenezumab binds to monomeric as well as aggregated forms of A β in vitro, with high affinity for A β oligomers, the form of A β hypothesized to mediate neurotoxicity in AD. **Objective:** To demonstrate the ability of crenezumab to protect human neurons in vitro from A β toxicity using our human iPSC neuronal model. **Methods:** Donor iPSC neurons were differentiated and maintained in 384-well assay plates for 2 months before experimentation. We implemented automation to systematically and reproducibly maintain neurons for long duration in a high-throughput manner. High-content imaging was conducted to analyze cellular phenotypes. More than 1,000 neurons were imaged per well, and 4 wells were imaged per condition. Image analysis scripts were generated for unbiased quantification of cellular phenotypes. **Results:** Our in vitro human iPSC neuron model of AD manifested several disease-related phenotypes, including plaque-like structures surrounded by phosphorylated tau-positive dystrophic neurites, synapse loss, dendrite retraction, axon fragmentation, tau translocation to the somatodendritic compartment and phosphorylation and, finally, neuronal cell death. In vitro studies showed that crenezumab, but not a

control antibody, protected neurons from all these pathologies in a dose-dependent manner, even from downstream AD pathology phenotypes such as tau phosphorylation and neuronal death. This result supports the intimate link between A β toxicity and tau pathology. Small-molecule inhibitors of known kinases in the AD signaling pathways also confer protection; however, none have been shown to be as effective as crenezumab. **Conclusions:** The ability of crenezumab to protect human neurons from A β toxicity-induced synapse loss, dendrite retraction, axon breakage, tau translocation and phosphorylation and, finally, neuronal cell death supports the clinical rationale for crenezumab as a potential treatment for AD.

Theme: New therapies and clinical trials

P5: THERAPEUTIC MONITORING AND PREDICTION OF THE EFFECTIVENESS OF NEUROTROPHIC THERAPY IN PATIENTS WITH MILD COGNITIVE IMPAIRMENT OF THE AMNESTIC TYPE. S.I. Gavrilova¹, O.M. Volpina², I.V. Kolykhalov¹, N.D. Selezneva¹, Y.B. Fedorova¹, D.O. Karaev², A.V. Kamynina² ((1) *Mental Health Research Center, Moscow*; (2) *Institute of bioorganic chemistry M.M.Shemyakin and Y.A.Ovchinnikov Russian Academy of Sciences, Moscow*)

Background: The aim of the study was to assess the immediate and delayed therapeutic effects of course of Cerebrolysin therapy and to identify biomarkers for monitoring the effectiveness of treatment and the long-term prognosis of the therapy in patients with amnesic MCI (aMCI). **Materials and methods:** the study included 19 patients, 15 women and 4 men aged from 56 to 85 years (mean age 72 years). The condition of the patients met the diagnostic criteria of aMCI. All patients underwent one course 20 intravenous infusions of Cerebrolysin therapy (the dose was 30 ml in 100 ml of physiological solution once a day with a gradual increase the dose during four days). Evaluation parameters were measured at the beginning of the study and after 4 and 12 weeks. Evaluation of the effectiveness of therapy was measured at 0, 4, 10, 26 week of the study on the following scales: CGI, MMSE, MoCA-test, MDRS, FAB, CDT, BNT, test of 10 words Recall, Test of the naming of digits in direct order. The blood serum of 19 patients were studied at 0, 10 and 26 weeks for the detection of autoantibodies to neuronal acetylcholine receptor $\alpha 7$ -type and neurotrophins receptor P75. To study the level of autoantibodies in serums of patients have been used synthetic peptide fragments of each of the neuronal receptors: a fragment 173-193 of the acetylcholine receptor and a fragment of the receptor 155-164 neurotrophins P75 (serum was tested by method of solid-phase enzyme immunoassay). **Results:** Statistically significant improvement of cognitive functioning on all scales was revealed immediately after the end of therapy (4 weeks). In 10 weeks, the study revealed the preservation of the achieved therapeutic effect on most of the tests. By the end of the study (26 weeks) the therapeutic effect was maintained for 4 out of 9 tests and a slight decrease in estimates for the remaining cognitive tests, but the estimate for 7 out of 9 cognitive tests remained significantly higher than before treatment. The only exception was the tests of verbal and categorical Association and memorization of 10 words. In the blood serum of patients with MCI the autoantibodies was found only to a fragment of 155-164 receptors of neurotrophins P75 (median 0.369). The level of autoantibodies against fragment 173-193 of acetylcholine receptor in all samples was low and

no changes were observed in patients as a result of therapy. The pilot study revealed clinical and biochemical indicators of reliable clinical significance for predicting the long-term therapeutic effect of the course of treatment with Cerebrolysin infusions: the age of patients older than 70 years, a higher initial evaluation for the MoCA test, the best initial indicators for the test «memory» of the scale of Matisse dementia, a high baseline level of autoantibodies to the neurotrophin receptor P75.

P11: 11 β -HYDROXYSTEROID DEHYDROGENASE TYPE 1 INHIBITORS PHARMACOLOGICAL MECHANISM OF POTENTIAL THERAPEUTIC USES- A SYSTEMATIC REVIEW. Sarah Gregory¹, John W. Ketelbey², Tamara Miller², Vincent S Ruffles², Craig W. Ritchie¹ ((1) *University of Edinburgh, Edinburgh, UK*; (2) *Actinogen Medical Ltd, Sydney, New South Wales, Australia*)

Background: Drug development in the field of Alzheimer's Disease (AD) has proven difficult, with few targets, multiple candidate failures, and only 5 compounds licensed for symptomatic treatment. 11 β -hydroxysteroid dehydrogenase type 1 (11 β -HSD1) inhibitors are novel compounds currently being investigated as potential therapeutics for the treatment of mild Alzheimer's dementia. This is a relevant target because elevated 11 β -HSD1 in the hippocampal and neocortical regions of the brain has been observed with ageing and is associated with cognitive decline as seen in AD. Moreover higher plasma cortisol levels are also associated with a more rapid cognitive decline in those with AD. Increased plasma cortisol in amyloid-beta positive cognitively normal older adults was associated with a faster cognitive decline. UE2343 (XanamemTM) is an 11 β -HSD1 inhibitor that has been selected for trials in patients to test the hypothesis that inhibition of 11 β -HSD1 may lead to improvements in cognition for people with AD, with a phase II study currently underway (ClinicalTrials.gov Identifier: NCT02727699). Historically Carbenoxolone, also an 11 β -HSD1 inhibitor, has been demonstrated to improve verbal fluency in a small sample of healthy elderly men and verbal memory in a small samples of patients with type 2 diabetes, again demonstrating the therapeutic potential of these inhibitors. The role of cortisol has also been investigated in psychiatric conditions such as at-risk psychosis populations, post-traumatic stress disorder and depression, as well as systemic illnesses such as diabetes. These clinical conditions may all be of interest as possible therapeutic targets for 11 β -HSD1 inhibitors, with hypercortisolism implicated in the disease pathways. This systematic review will look at the pre-clinical and human studies of 11 β -HSD1 inhibitors to understand their pharmacological underpinning and potential health outcomes. **Objectives:** The objectives of this review are to evaluate 11 β -HSD1 inhibitors as potential therapeutic agents. The review will answer the following questions: 1. What is the role of cortisol in conditions that have the potential for treatment with 11 β -HSD1 inhibitors? The conditions of interest are cognitive impairment, post-traumatic stress disorder, depression, anxiety, psychosis, diabetes, metabolic syndrome and obesity. 2. What is the pharmacodynamics basis of why and how 11 β -HSD1 inhibitors may or should be beneficial in aforementioned therapeutic areas? 3. What are the therapeutic potential and health outcomes of 11 β -HSD1 inhibitor use? **Methods:** MEDLINE, BioMed and EMBASE as well as abstracts from relevant conferences and reference lists will be searched to identify studies addressing the objectives in a range of disease areas. Preclinical studies,

randomised clinical trials, observational studies and case series reports published in English between 1993 and 2018 will be included. Two reviewers will independently screen abstracts and then full papers for suitability of inclusion in the review against predetermined criteria as detailed in the protocol. Data will be extracted using a pre-defined data capture form and risk of bias assessment will be completed using tools appropriate to the publication type. The full systematic review protocol can be accessed via the online Prospero database. **Results:** Analyses of the findings are on-going. The results will be presented at the 2018 Clinical Trials on Alzheimer's disease (CTAD) meeting in Barcelona.

P20: SUVN-502 - BASELINE CHARACTERISTICS OF PHASE 2A STUDY IN MODERATE ALZHEIMER'S DISEASE - FIRST-IN-CLASS TRIPLE COMBINATION OF SUVN-502+DONEPEZIL+MEMANTINE - A PROMISING NEW APPROACH FOR THE SYMPTOMATIC TREATMENT OF ALZHEIMERS DISEASE. Ramakrishna Nirogi, Jyothsna Ravula, Satish Jetta, Koteswara Mudigonda, Vinod Kumar Goyal, Santosh Kumar Pandey, Gopinadh Bhyrapuneni, Renny Abraham, Vijay Benade, Pradeep Jayarajan, Anil Shinde, John Ieni, Venkat Jasti (*Discovery Research, Suven Life Sciences Ltd, Hyderabad, India*)

Background: SUVN-502 is a pure 5-HT₆ receptor antagonist being developed for the treatment of Alzheimer's disease (AD). SUVN-502 is currently being evaluated in a phase 2a, multicenter, randomized, double-blind, parallel group, 26-week, placebo controlled proof of concept study. SUVN-502 demonstrated good ADME properties, robust efficacy and safety in animal models. In healthy human subjects, SUVN-502 was well tolerated following single or multiple oral administrations. **Objectives:** Baseline characteristics of the SUVN-502 phase 2a study population. **Methods:** Proof of concept study is a multicentre trial within USA and regulated by US FDA. A total of 537 subjects with moderate AD receiving stable doses of donepezil and memantine are being recruited. Randomized subjects will receive either placebo or SUVN-502 (50 or 100 mg) on top of donepezil and memantine. Primary efficacy endpoint is Alzheimer's disease assessment scale- Cog 11. Secondary outcome measures include clinical dementia rating scale - sum of boxes, change in Alzheimer's disease cooperative study - activities of daily living inventory, neuropsychiatric inventory - 12 item depression and dementia, Cornell scale for depression and dementia, change in mini mental state examination, Columbia suicide severity rating scale, safety and tolerability. Subjects completing the study are eligible to enroll in a 6 month expanded access program of SUVN-502. **Results:** The phase 2a study was initiated in Nov-2015. Baseline characteristics of the study population will be presented at CTAD 2018. **Conclusions:** This phase 2a trial evaluates the efficacy and safety of SUVN-502 on top of stable background donepezil and memantine therapy in individuals with moderate AD. Efficacy results from the study are expected in 2019.

P23: EFFICACY AND SAFETY OF TRIGRILUZOLE (BHV-4157) IN PATIENTS WITH MILD TO MODERATE ALZHEIMER'S DEMENTIA: T2 PROTECT AD PHASE 2 STUDY DESIGN. Irfan A. Qureshi¹, Karen Messer², Kirsten Erickson², Robert M. Berman¹, Carolyn Revta², Tilman Oltersdorf², Branko Huisa², Diane Jacobs², David Salmon², Doug Galasko², Thomas O. Obisesan³, Neelum Aggarwal⁴, Jacobo Mintzer⁵, Judith Heidebrink⁶, Amanda Smith⁷, Miranda N. Reed⁸, Holly C. Hunsberger⁸, Lia Donahue¹, Kimberly Gentile¹, David A. Stock¹, Vladimir Coric¹, Howard Feldman² ((1) *Biohaven Pharmaceuticals, Inc., New Haven, CT, USA;* (2) *Alzheimer's Disease Cooperative Study, University of California at San Diego, La Jolla, CA, USA;* (3) *Howard University, Washington, DC USA;* (4) *Rush University Medical Center, Chicago, IL, USA;* (5) *Roper St. Francis Hospital, Charleston, SC, USA;* (6) *University of Michigan, Ann Arbor, MI, USA;* (7) *University of South Florida Health Byrd Alzheimer Institute, Tampa, FL, USA;* (8) *Auburn University, Auburn, AL, USA*)

Objective: Describe the scientific rationale and design of the T2 PROTECT AD study. **Background:** Trigriluzole (BHV-4157) is a novel, rationally designed 3rd-generation tripeptide prodrug of the glutamate modulator, riluzole, and offers improved bioavailability, pharmacology, safety, and dosing. Trigriluzole is actively absorbed in the gut (via the PepT1 transporter), is not subject to a negative food effect, generates predictable exposures of its active metabolite, bypasses first-pass metabolism, reduces riluzole burden on the liver, and allows exploration of higher concentrations of active metabolite with once daily dosing. Recently emerging preclinical evidence suggests that treatment with the active metabolite of trigriluzole may rescue Alzheimer's disease (AD)-related cognitive impairments (Figure 1) and reduce pathological changes¹⁻² (Figure 2). Molecular mechanisms may include attenuating structural and functional deficits in glutamatergic synapses¹⁻²; mitigating tau and A β induced hippocampal electrophysiological perturbations³⁻⁵; reversing aberrant expression of genes involved in synaptic morphology, transmission, and plasticity⁶; and even reducing pathological tau levels¹ (Figure 2). **Methods:** T2 PROTECT AD is a phase 2, randomized, double-blind, placebo-controlled study that is planned to enroll approximately 292 patients. Qualified patients, aged 50 to 85 years, diagnosed with Alzheimer's dementia (NIA/Alzheimer's Association Guidelines) of mild to moderate severity, including a Mini-Mental State Examination (MMSE) score of 14-24, will be randomized 1:1 to receive trigriluzole (280 mg) or placebo administered once daily for 48 weeks. The primary efficacy endpoint, assessed at Week 48, will compare the change from baseline in Alzheimer's Disease Assessment Scale-Cognitive 11 score in trigriluzole- vs. placebo-treated patients. Secondary endpoints will include change from baseline in trigriluzole- vs. placebo-treated patients on the following outcome measures: Clinical Dementia Rating-Sum of Boxes; QUARC volumetric MRI (bilateral hippocampal volumes, lateral ventricles, and whole brain volume); Neuropsychiatric Inventory; Alzheimer's Disease Cooperative Study-Activities of Daily Living; National Alzheimer's Coordinating Center Uniform Data Set Neuropsychological Test Battery (Craft Story 21 Recall [Immediate & Delayed], Benson Figure [Copy & Delayed Recall], Multilingual Naming Test, Letter & Category Fluency, Trail Making Test A & B, Number Span Forward & Backward); MMSE; and Montreal Cognitive Assessment. Safety endpoints will assess mortality rates, serious adverse

events, adverse events, clinical safety laboratories, a measure of suicidality, physical examinations and significant electrocardiogram changes. An interim analysis for futility is planned to be conducted on a panel of two interim outcomes, when the first 50 randomized patients in each arm have received treatment for a minimum of 24 weeks. **Results:** The study is currently ongoing. **Conclusions:** T2 PROTECT AD will evaluate the efficacy and safety of trigriluzole in patients with AD of mild to moderate severity. Acknowledgements: The ADCS is gratefully supported by the National Institute on Aging through NIH U19 AG010483 (UCSD Alzheimer's Disease Cooperative Study). References: 1. Hunsberger HC, et al. *J Neurochem.* 2015;135(2):381-394. 2. Pereira AC, et al. *Proc Natl Acad Sci.* 2014;111(52):18733-18738. 3. Ren SC, et al. *Amyloid.* 2015;22(1):36-44. 4. Ren SC, et al. *Neurosci Lett.* 2014;580:62-67. 5. Hunsberger HC, et al. *Metab Brain Dis.* 2016;31(3):711-715. 6. Pereira AC, et al. *Mol Psychiatry.* 2017;22(2):296-305.

Figure 1

Riluzole improves performance of rTg(TauP301L)4510 mice in the Morris water maze (MWM). Riluzole treatment (12.5 mg/kg/day p.o.) rescued the spatial reference memory deficits observed for vehicle-treated TauP301L mice, as indicated by an increase in platform crossing index (PCI) in the riluzole-treated TauP301L mice. (Mean \pm SEM; * p<.05 Veh-Control vs. Veh-TauP301L, ## p<.01 Ril-Tau-301L vs. Veh-TauP301L; n=19-24)1.

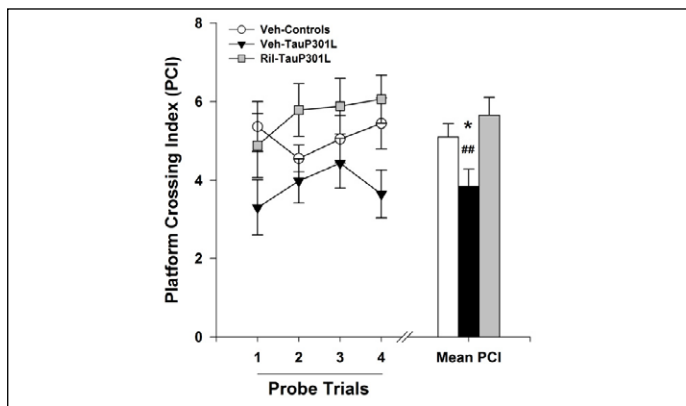
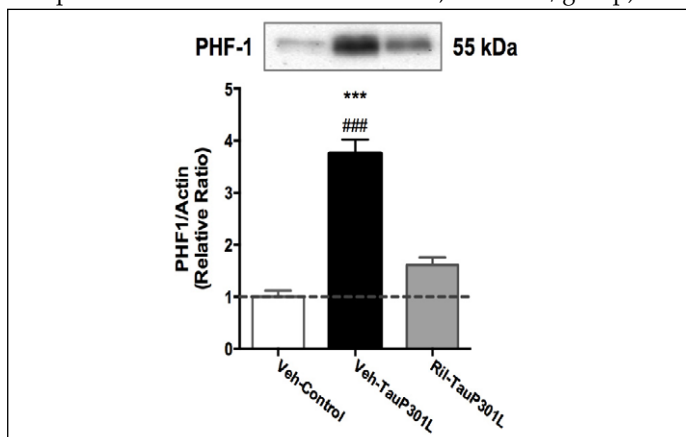

Figure 2

Riluzole attenuates tau pathology in rTg(TauP301L)4510 mice. Treating TauP301L mice with riluzole attenuates tau pathology as indicated by reductions in staining for tau phosphorylation at Ser396/Ser404 (PHF-1). (Mean \pm SEM; *** p<.001 Veh-Control vs. Veh-TauP301L, ### p<.01 Ril-Tau-301L vs. Veh-TauP301L; @ p<0.5 Veh-Control vs. Ril-TauP301L; n = 12-14/group)1



P56: GAMMA-SECRETASE MODULATION HAS MULTIPLE ANTI-AMYLOIDOGENIC EFFECTS IN VIVO. Bengt Winblad^{4,6}, Gunnar Nordvall^{1,2,3,4}, Ping Yan⁵, Johan Lundkvist^{1,2,3,4}, Johan Sandin^{1,2,3,4}, Henrik Biverstål⁴, Henrik Zetterberg⁷, Rebecka Klintonberg³, Mats Ferm³, John R Cirrito⁵, Jin-Moo Lee⁵ ((1) *AlzeCure Pharma AB, Drug Discovery & Development, Huddinge, Sweden*; (2) *AlzeCure Foundation, Preclinical Research, Huddinge, Sweden*; (3) *AstraZeneca R&D, CNS & Pain iMed, Södertälje, Sweden*; (4) *Karolinska Institutet, Dept NVS, Div of Neurogeriatrics, Solna, Sweden*; (5) *Washington University School of Medicine, Dept of Neurology, St Louis, USA*; (6) *Karolinska University Hospital, Geriatric Clinical Trial Unit, Huddinge, Sweden*; (7) *Sahlgrenska University Hospital, Clinical Neurochemistry Laboratory, Mölndal, Sweden*)

Objective: Gamma-secretase cleaves APP intracellularly to produce Abeta fragments which are thought to be toxic and crucial to the pathogenesis of AD. Gamma-secretase inhibitors (avagacestat and semagacestat) failed with an unexpected degree of toxicity and worsening of toxicity. These side effects are not expected using gamma-secretase modulators (GSMs). **Objectives:** Aggregation of the Abeta42 peptide (Aβ42), results in amyloid plaque formation, a process that plays a pivotal role in early Alzheimer disease pathogenesis. To interfere with Aβ42 production is therefore a prioritized therapeutic strategy. Modulators of γ-secretase, the enzyme that generates Aβ, do not affect γ-secretase activity per se, but alters the lengths of generated Aβ peptides. As such, the production of the longer amyloidogenic peptides Aβ40 and Aβ42 is decreased while the production of shorter, less amyloidogenic peptides such as Aβ37 and 38, is increased. In this project, we set out to explore the impact of Aβ37 and Aβ38 on Aβ42 aggregation and the effect of GSMs on Aβ-amyloidosis in vivo. **Methods:** In vitro: The impact of Aβ37 and Aβ38 on Aβ42 aggregation was studied using different aggregation assays. In vivo: APP/PS1 mice were treated with AZ4126, a GSM, and Aβ37, 38, 40, and 42 were measured using in vivo microdialysis. The effect of chronic AZ4126 treatment on amyloid plaque appearance and growth was examined using serial intravital 2-photon imaging in APP/PS1 mice. **Results:** In vitro: Aβ42, but not Aβ37 and Aβ38, showed potent aggregation in two different assays that monitored Ab oligomerization and fibrillation, respectively. When mixed together at equimolar levels, both Aβ37 and 38 inhibited Aβ42 aggregation. In vivo: AZ4126 caused a pronounced modulation of interstitial fluid Aβ levels: Aβ40 and 42 were decreased while Aβ37 and 38 were increased, respectively. 28-days treatment of AZ4126 resulted in inhibition of plaque formation, plaque growth and, in some cases, stimulated plaque regression. **Conclusion:** GSMs are a novel class of compounds that alters the cleavage of APP, increasing the smaller Aβ peptides, Aβ37 and 38. Our data suggest that this Aβ peptide profile mediates anti-amyloidogenic activity, attenuating plaque growth and appearance, and in some cases reducing pre-existing amyloid pathology.

P60: DISCOVERY OF NOVEL MOLECULAR CHAPERONE MODULATORS FOR THE TREATMENT OF TAU PATHOGENESIS IN ALZHEIMER'S DISEASE.

Rajnish Kumar¹, Pavel Pavlov¹, Bengt Winblad^{1,2} ((1) Department of Neurobiology, Care Sciences and Society, Center for Alzheimer Research, Division of Neurogeriatrics, Karolinska Institutet, Solna, Sweden; (2) Department of Geriatric Medicine, Karolinska University Hospital, Huddinge, Sweden)

Objective: Alzheimer disease (AD) and Dementia with Lewy bodies are two most common forms of dementia disorders representing almost 70-80% of dementia population. The pathology of AD is very complex and is not understood completely yet. However, presence of extracellular senile plaques made up of amyloid- β peptide and neurofibrillary tangles (NFTs) made up of microtubule associated protein tau in the diseased brain are two major hallmarks of AD. Lately, the research efforts have been made towards management of tauopathy because of repeated failures of anti-amyloid antibodies. It is known [1, 2] that heat shock protein-90 (Hsp90) plays an important role in the prevention of protein misfolding and aggregation with the help of several co-chaperones. Especially, cis-trans peptidyl-prolyl isomerase FK506 binding protein 51 (FKBP51) coordinates with Hsp90 to provoke tau pathogenesis by reducing tau aggregation [3]. Therefore, we aim to develop novel small inhibitors of this chaperone-co-chaperone interaction to treat tauopathy in AD and other related dementia disorders. **Objectives:** As there is a current unmet need of new drug therapeutics against AD and other dementia disorders, our overall objective of this study was to design and develop small molecule inhibitors of the tauopathy through inhibition of FKBP51-Hsp90 interaction. Keeping in view the role of FKBP51 in tau metabolism, this seems to be a legitimate target to treat tauopathy in the disease brain and the small molecule inhibitors against this may be developed as novel therapeutics against AD and other dementias with tauopathy. **Methods:** We have used a validated computation-guided structure based drug design strategy for discovery of small molecule inhibitors of FKBP51-Hsp90 co-chaperone interaction. In order to use the structural information of the interaction between FKBP51-Hsp90 complex, we first solved the 3D structure of the complex using X-ray crystallography (Fig. 1)[4]. The hotspots of this protein-protein interaction were determined and further used for molecular docking based virtually screening to screen a large library of commercially available small molecules. The top hits were procured and tested to identify several sub-micromolar inhibitors of the target. The identified molecules were tested in primary neuroblastoma (SH-SY5Y) cell line determine their effect on reduction in tau level. **Results:** We have solved the crystal structure of FKBP51-Hsp90 C terminal MEEVD peptide with a resolution of 2.4 Å. It consists of an N-terminal PPI domain and a C-terminal TPR domain, which binds to C-terminal of Hsp90 and mediates the chaperone action. Using a combined approach we have identified several potent small molecule inhibitors of the FKBP51-Hsp90 complex with broad structural diversity. These hit compounds have shown promising results in decreasing the tau level in primary neuroblastoma (SH-SY5Y) cell line studies. Further, the identified inhibitors also exhibit favorable pharmacokinetic properties such as solubility and BBB permeability as determined in mice animal model. **Conclusions:** Here we report identification of small molecule inhibitors of FKBP51-Hsp90 complex with

a huge potential as drug candidates against the tauopathy in AD and other related disorders. We believe that, our study would help in the design and development of small molecules inhibitors targeting the chaperoning mechanism which plays a central role in the tauopathy in AD and other related dementia disorders. Selected References: 1. Ou, J.R., et al., Heat shock protein 90 in Alzheimer's disease. *Biomed Res Int*, 2014. 2014: p. 796869. 2. Antonella Marino, G., et al., Alzheimer's Disease and Molecular Chaperones: Current Knowledge and the Future of Chaperonotherapy. *Current Pharmaceutical Design*, 2016. 22(26): p. 4040-4049. 3. Blair, L.J., et al., Accelerated neurodegeneration through chaperone-mediated oligomerization of tau. *J Clin Invest*, 2013. 123(10): p. 4158-69. 4. Kumar, R., et al., Combined x-ray crystallography and computational modeling approach to investigate the Hsp90 C-terminal peptide binding to FKBP51. *Sci Rep*, 2017. 7(1): p. 14288.

Figure 1

Crystal structure of human FKBP51 in complex with C-terminal MEEVD peptide of Hsp90 showing FK, FK2 and TPR domains



P79: COGNIXTRA PREVENTIVE TREATMENT AFFORDS NEUROPROTECTION AGAINST AMYLOID BETA 25-35 PEPTIDE-INDUCED TOXICITY IN MICE.

Francois J. Roman¹, Johann Meunier¹, Laura Ceolin¹, Jean-Marie Butterlin², Guillaume Blivet³, Jacques Touchon⁴ ((1) Amylgen, Montferrier sur Lez - France; (2) Health Optimization Devices B.V. - Maastricht, Netherlands, www.cognixtra.com; (3) Montpellier - France; (4) INSERM U1061 & Montpellier University, Montpellier - France)

Background: Alzheimer (AD) is a complex neurodegenerative disorder and even though no cure is still available, there are considerable research advances for treating and slow down its symptoms. In recent years, several studies have shown the importance of nutraceutical approach in order to delay the onset and to reduce the risk of AD and dementia. To date many products have been tested in patients with not always convincing outcomes. In this study we investigate the neuroprotective efficacy of docosahexaenoic acid (DHA), glutathione (GSH), phosphatidylcholine (PC), curcumin (CUR) and resveratrol (RES) given alone or in combination for thirty consecutive days as a preventive treatment in a well recognized mouse model of AD. This model consists in a

unique intracerebroventricular (i.c.v.) injection of oligomeric amyloid-beta peptide 25-35 (A β 25-35) in mice [1] which is able to mimic both cognitive impairment and associated neuronal degeneration. **Methods:** Male Swiss mice 5-6 weeks old were anesthetized with isoflurane 2.5% and injected i.c.v. with A β 25-35 peptide (9 nmol/mouse) or Scramble A β (Sc. A β) peptide (9 nmol/mouse), in a final volume of 3 μ l/mouse, according to the previously described method [2]. Mice were treated by oral gavage for 20 days before the i.c.v. injection and 10 days after that until the end of the behavioral experiments, that was also the day of their sacrifice. The daily doses of the various products were (expressed in mg/mouse): GSH : 3.01; PC: 2.07; CUR: 3.67, RES: 1.38; DHA: 5.33. Several combinations of the different products were tested. CogniXtra contained all of these compounds combined together. Mice were tested for assessing short and long-term memory abilities. For short memory, mice performed spontaneous alternation in the Y-maze, a three arms apparatus that gives an index of spatial working memory according to the procedure already described [3, 4]. Step through passive avoidance (STPA), an index of contextual long-term memory, was tested using the apparatus described previously [3, 4] and consisting of two compartments, one white and one black separated by a guillotine door. Step-through latency, i.e., the latency spent to enter the dark compartment, and escape latency, which is the time to get out from the dark compartment, were recorded. After the last behavioral test animals were euthanized, their brain was removed and hippocampus was dissected out. The hippocampus was used to determine lipid peroxidation (LPO) levels using a colorimetric method [5]. Lipid peroxidation is one of the most important key features for AD mouse model and patients. **Results:** Cognitive impairments were evaluated starting from eight days after the i.c.v. injection. Indeed the toxic A β 25-35 peptide induced important spatial working memory deficits by decreasing very significantly the percentage of alternation of mice in the Y-maze as compared to Sc. A β injected mice and induced very significant contextual long-term memory deficits in the STPA test in terms of step-through latency and escape latency. On the same animals, compared to Sc. A β injected mice, A β 25-35 peptide induced a very significant elevation of LPO. When animals were submitted to a treatment with a combination of GSH/PC alone, a combination of CUR/RES or DHA alone during 30 days, no improvement was observed as compared to the effects produced by A β 25-35 peptide injection. When animals were treated during 30 days with combinations of GSH/PC + CUR/RES, or GSH/PC + DHA or GSH/PC + CUR/RES + DHA (cogniXtra) significant improvements were obtained on memory tests and on normalization of LPO elevation. However, only cogniXtra combination was able to fully reverse all memory deficits and fully normalize the levels of LPO elevation in the hippocampus. More particularly, the superiority of cogniXtra was the most obvious in the STPA test evaluating long term memory. **Conclusion:** Further experiments will be performed to characterize more completely the neuroprotective effects of cogniXtra, which may be considered as a very interesting food supplement for the prevention of neurodegenerative diseases such as Alzheimer's disease. References: [1] Maurice T, Lockhart BP, Privat A. Amnesia induced in mice by centrally administered beta-amyloid peptides involves cholinergic dysfunction. *Brain Res.* 1996;706:181-93. [2] Haley TJ, McCormick WG. Pharmacological effects produced by intracerebral injection of drugs in the conscious mouse. *Br J Pharmacol Chemother.*

1957;12:12-5. [3] Meunier J, Villard V, Givalois L, Maurice T. The gamma-secretase inhibitor 2-[(1R)-1-[(4-chlorophenyl)sulfonyl](2,5-difluorophenyl) amino]ethyl-5-fluorobenzenebutanoic acid (BMS-299897) alleviates Abeta1-42 seeding and short-term memory deficits in the Abeta25-35 mouse model of Alzheimer's disease. *Eur J Pharmacol.* 2013;698:193-9. [4] Villard V, Espallergues J, Keller E, Vamvakides A, Maurice T. Anti-amnesic and neuroprotective potentials of the mixed muscarinic receptor/sigma 1 (sigma1) ligand ANAVEX2-73, a novel aminotetrahydrofuran derivative. *J Psychopharmacol.* 2011;25:1101-17. [5] Hermes-Lima M, Willmore WG, Storey KB. Quantification of lipid peroxidation in tissue extracts based on Fe(III)xylenol orange complex formation. *Free Radic Biol Med.* 1995;19:271-80.

P84: CLINICAL DEVELOPMENT OF AXS-05 (DEXTROMETHORPHAN/BUPROPION) FOR AGITATION ASSOCIATED WITH ALZHEIMER'S DISEASE. Herriot Tabuteau, Amanda Jones, Cedric O'Gorman (*Axsome Therapeutics Inc., USA*)

Background: Neuropsychiatric symptoms are highly prevalent in patients with Alzheimer's disease (AD) causing great distress to patients and their caregivers. Symptoms of agitation and aggression are particularly bothersome, are a leading cause of early placement in nursing homes, and associated with accelerated cognitive decline and increased mortality. Despite the scope of the problem, there still remains no FDA-approved treatment for agitation associated with AD. AXS-05 is a novel, oral, investigational medicine consisting of dextromethorphan and bupropion, in late-stage clinical development for agitation associated with AD. Dextromethorphan is an NMDA receptor antagonist, sigma-1 receptor agonist, and an inhibitor of the serotonin and norepinephrine transporters. The clinical utility of dextromethorphan has been limited by its rapid and extensive metabolism in humans through CYP2D6 rendering it difficult to achieve therapeutic plasma concentrations. Bupropion serves to increase the bioavailability of dextromethorphan enabling its use for treating neuropsychiatric symptoms. Bupropion is also a norepinephrine and dopamine reuptake inhibitor. Both dextromethorphan and bupropion are also nicotinic acetylcholine receptor antagonists, and have anti-inflammatory properties. The biological pathways targeted by these pharmacological actions have been implicated in the neuropsychiatric symptoms of AD. **Objectives:** The objectives are to examine the clinical and nonclinical rationale for the development of AXS-05 for the treatment of agitation associated with AD, to present Phase 1 pharmacokinetic results supporting the conduct of efficacy trials of AXS-05 in this condition, and to present the design and status of an ongoing efficacy and safety trial of AXS-05 in this condition. **Methods:** The pharmacokinetics of dextromethorphan after administration of AXS-05, and the safety and tolerability of AXS-05, were assessed in Phase 1 trials. Clinical evidence supporting the relevance of neurotransmitter receptor systems targeted by AXS-05 to agitation associated with AD were examined. The in vitro activity of the components of AXS-05 on target neurotransmitter receptor systems were examined. Drug plasma concentrations achieved with AXS-05 in the Phase 1 trials were compared to levels relevant to the target neurotransmitter receptor systems. Based on the results of these analyses, an efficacy trial of AXS-05 in AD patients with agitation was designed

and initiated. **Results:** Substantial and significant increases in dextromethorphan plasma concentrations were observed with administration of AXS-05 in Phase 1 trials. AXS-05 was safe and generally well tolerated. Clinical evidence suggests that altered glutamate transmission may play a role in behavioral and cognitive changes in dementia. Clinical data with agents that, like AXS-05, modulate glutamate signaling through NMDA and sigma-1 (e.g. memantine, fluvoxamine, donepezil) have shown potential effects in patients with behavioral disorders and AD. Dextromethorphan has previously been shown, in the presence of metabolic inhibition, to reduce agitation symptoms in patients with AD, and the relevance of its serotonergic properties in this indication are further supported clinical results with citalopram. Drug plasma concentrations achieved with AXS-05 in the Phase 1 pharmacokinetic trials target these receptor systems. The ADVANCE (Addressing Dementia via Agitation Centered Evaluation) trial was initiated and is ongoing. ADVANCE is a Phase 2/3, randomized, double-blind, placebo-controlled, 5-week study in subjects experiencing agitation associated with AD. Approximately 435 eligible subjects are planned to be randomized in a 1:1:1 ratio to treatment with AXS-05, placebo, or bupropion. The primary efficacy outcome measure is the Cohen-Mansfield Agitation Inventory (CMAI). ADVANCE incorporates an interim futility analysis, planned at approximately 30% target randomized subjects, and an interim efficacy analysis, planned at approximately 60% target randomized subjects. **Conclusions:** There is an urgent need for safe and effective treatments to tackle the significant clinical challenge presented by symptoms of agitation in patients living with AD. AXS-05 is a novel, oral, investigational medicine consisting of dextromethorphan and bupropion. The scientific rationale for the potential of AXS-05 to ameliorate neuropsychiatric symptoms in AD is supported by the mechanisms of action of AXS-05, the positive pharmacokinetic interaction of its components, the ability of AXS-05 to achieve target plasma drug concentrations that target relevant neurotransmitter systems, and clinical evidence with dextromethorphan and other agents which share the mechanisms of action of AXS-05. The safety and efficacy of AXS-05 is being evaluated in an ongoing Phase 2/3 clinical trial in patients with agitation associated with AD.

P85: PHARMACOKINETICS AND SAFETY PROFILE OF INTRAVENOUS ADMINISTRATION OF ALLOPREGNANOLONE IN PATIENTS WITH EARLY ALZHEIMER'S DISEASE. Gerson D. Hernandez¹, Naoko Kono², Claudia M. Lopez¹, Ron Irwin³, Kathleen Rodgers¹, Jimmy Wu⁴, Rosario Mollo⁴, Sonia Pawluczyk⁵, Meng Law⁶, Wendy Mack², Lon Schneider⁵, Roberta D. Brinton¹ *(1) Center for Innovation in Brain Science, University of Arizona, Tucson, Arizona, USA; (2) Department of Preventive Medicine, Keck School of Medicine of the University of Southern California, Los Angeles, CA, USA; (3) School of Pharmacy, University of Southern California, Los Angeles, CA, USA; (4) TOMO Pharmacometrics, LLC, San Mateo, USA; (5) Department of Psychiatry & The Behavioral Sciences, Keck School of Medicine of the University of Southern California, Los Angeles, CA, USA; (6) Department of Radiology, Keck School of Medicine of the University of Southern California, Los Angeles, CA, USA)*

Background: Until now, no interventions have demonstrated substantial therapeutic efficacy to prevent, delay or treat Alzheimer's disease (AD) and many have accelerated disease

progression. Current thinking in the field embraces the complexity of AD pathophysiology, which has enabled a more diverse therapeutic pipeline targeting multiple aspects of the disease. Targeting the regenerative system of the brain while simultaneously activating systems to reduce burden of AD pathology is a novel and innovative therapeutic approach. The neurosteroid allopregnanolone (Allo) is a first in class regenerative therapeutic for delaying progression and treating AD with a strong foundation of human safety exposure. In this phase 1 trial we assess the safety, tolerability and pharmacokinetics (PK) of intravenous (IV) administration of Allo. **Objectives:** Primary goals were to assess safety and tolerability of Allo at different doses over 12 weeks of once per week exposure. Specific objectives of this multiple ascending dose (MAD) trial were determination of the safety, tolerability, pharmacokinetics and amyloid-related imaging abnormalities (ARIA) of Allo to establish a safe non-sedative dose for a future phase 2 study of efficacy. **Methods:** A randomized double-blind, placebo-controlled, multiple ascending dose, phase 1 clinical trial was conducted in patients with mild cognitive impairment (MCI) due to AD or mild AD. Men and women age ≥ 55 years, with a MMSE score ≥ 20 and clinical dementia rating of 0.5-1 were recruited to the study. Participants were randomly assigned to receive weekly intravenous treatment of Allo or placebo (3:1 ratio) and were evenly distributed across 3 dosing cohorts (2mg, 4mg and 6-18mg). Primary outcomes were to assess safety, tolerability and maximally tolerated dose (MTD) of Allo at the different doses administered IV once per week over 12 weeks. Safety was determined by assessing whether Allo was associated with adverse events (AE), serious adverse events (SAE), ARIA, and elevation of clinical laboratory measurements above pre-established critical values. Pharmacokinetic analysis was conducted at the start and end of 12-week exposure. Standard PK parameters were derived using Phoenix WinNonlin version 8.0. MTD was established by the onset of sedation, which was assessed with a combination of tools (Stanford sleepiness scale, mood rating scale and Bispectral index monitoring). ClinicalTrials.gov Identifier: NCT02221622. **Results:** A total of 24 patients were enrolled into the trial and participated in the PK assessment. Blood was collected at 15, 30, 45 minutes, and 1, 2, 4, 6 and 24 hours post the 30-minute infusion. First PK analysis showed that mean T_{max} was 30 minutes across all cohorts. Mean C_{max} at 2, 4 and 6mg was 14.5 \pm 7.3 ng/ml, 42.1 \pm 14.6 ng/ml and 60.1 \pm 12.8 ng/ml, respectively. The C_{max} closely correlated (R=0.77) with Allo delivered in mg/kg dose. Mean area under the curve (AUC) total exposure also showed a near linear dose dependent response. PK analysis of last infusion showed a mean T_{max} of 30 minutes across all cohorts. Mean C_{max} at 2, 4, 6 and 10mg was 28.9 \pm 8.7 ng/ml, 38.7 \pm 5.9 ng/ml, 58.5 \pm 16.3 ng/ml and 137.5 \pm 38.7 ng/ml, respectively. Mean plasma AUC values (AUC_{0-last}) at last infusion were 13, 25, 34, 76 ng²hr/mL, for Allo doses of 2, 4, 6, 10mg, respectively. MTD was established by onset of sedation at doses ≥ 10 mg, and a gender difference in the dose inducing sedation was observed (males ≥ 10 mg and females ≥ 14 mg). Twelve-week exposure to multiple doses of Allo once per week resulted in no reportable AE, SAE or ARIA. **Conclusion:** Allopregnanolone administered intravenously once a week for 12 weeks was well tolerated, appeared without adverse effects, and exhibited a favorable pharmacokinetic profile in our study population. Peak concentrations of Allo were observed at approximately 0.5 hours following the start of infusion for all doses, both at the start and end of 12-week

exposure. A safe non-sedative dose of Allo for a future phase 2 study was determined. Research supported by National Institute on Aging U01AG031115 to RDB; U01AG047222 to RDB; UF1AG046148 to RDB & LS; Alzheimer Drug Discovery Foundation to RDB P50 AG05142 USC ADRC (Schneider), ClinicalTrials.gov Identifier: NCT02221622.

P105: SM07883, A NOVEL DYRK1A INHIBITOR, REDUCED TAU PATHOLOGY – DISCOVERY AND PRECLINICAL DEVELOPMENT OF A POTENTIAL THERAPEUTIC FOR ALZHEIMER'S DISEASE. Benoît Melchior, Carolyn Lai, Karen Duong-Polk, Amanda Tjitro, Lauren Pitzer, Joshua Stewart, Luis Dellamary, Scott Anderson, Brian Hofilena, Chiao-Wen Chen, Charlene Barroga, Gopi Mittapalli, Sunil KC, Philippe Marchand, Yusuf Yazici (*Samumed, LLC, San Diego, USA*)

Background: Dual-specificity tyrosine phosphorylation-regulated kinase-1A (DYRK1A) overexpression in Alzheimer's Disease (AD) is correlated to tau hyperphosphorylation, formation of oligomers, and neurofibrillary tangle (NFT) formation. Elevated cellular stress signals such as A β and TNF α have been shown to induce DYRK1A activity, which in turn contributes to tau phosphorylation leading to tau pathology. Samumed is developing SM07883, a novel, orally bioavailable, small molecule, DYRK1A inhibitor as a potential therapeutic for AD or other chronic tauopathies. **Objectives:** • Assess the potential of SM07883 to inhibit tau hyperphosphorylation, aggregation, and NFT formation in mouse tau transgenic models. • Measure the effects of SM07883 on neuroinflammation. • Evaluate the effects of SM07883 on tau-associated functional phenotypes. • Establish the safety profile of SM07883 in toxicology studies to enable clinical trials. **Methods:** SM07883 selectivity and potency were evaluated in kinase panels, and inhibition of tau phosphorylation (pTau) was measured in cell-based assays. Increases in pTau and DYRK1A activity after treatment with A β ₄₂, A β ₂₅₋₃₅ or TNF α were measured in primary cortical neurons or microglial cells. The effects of SM07883 on LPS-induced TNF- α secretion were measured in cultured microglial cells and after intraperitoneal (IP) or intracerebroventricular (ICV) injections in mice. Cytokines were measured in plasma and brain lysates by electrochemiluminescence. SM07883 pharmacodynamics was measured in wild-type (WT) mice. To assess long-term efficacy, pTau and oligomeric and aggregated Tau were biochemically quantified in brain stems and spinal cords from ten-month-old JNPL3 mice (P301L human Tau overexpression mutation) orally administered SM07883 or vehicle (3 mg/kg, QD, 3 months). NFT containing cells with tau-positive inclusions were detected and quantified by immunostaining. Astrocyte activation was assessed using glial fibrillary associated protein (GFAP) staining with Western Blot quantification, and activated microglia were identified by Iba1 staining. Motor coordination was evaluated biweekly for 14 weeks after treatment initiation using a wire hang test. General tolerability was assessed by monitoring weight, morbidity, and mortality. GLP-compliant, 28-day, repeat-dose oral toxicity studies in both mice and monkeys were conducted with in-life, clinical pathology, histopathology, and toxicokinetic evaluations. **Results:** SM07883 selectively and potently inhibited DYRK1A kinase activity (IC₅₀ = 2 nM). Overexpression of both DYRK1A and the tau gene (HEK293T cells) increased tau phosphorylation. In these cells, treatment with SM07883 reduced pTau at multiple sites including Thr212, AT8, Thr181, and Ser396 (EC₅₀ 16, 69, 127, and 200 nM,

respectively). In pharmacokinetic studies, SM07883 was orally bioavailable across multiple species while crossing the blood brain barrier (brain to plasma ratios > 2 in rodents). Compared to vehicle, WT mice showed a dose-dependent reduction of transiently induced brain pTau in a pharmacodynamic model starting with a single, 1.25 mg/kg SM07883 dose (47%, p<0.001). JNPL3 mice treated with SM07883 demonstrated significant (p<0.05) reductions in Tau hyperphosphorylation, sarkosyl-insoluble tau fragments, aggregated Tau, and significantly lower tau-positive inclusions (NFTs) compared to vehicle. GFAP and Iba1 immunoreactivity were reduced and decreased GFAP immunoreactivity was confirmed by Western Blot (37%, p=0.001). Motor function in the wire hang test was significantly improved in SM07883-treated JNPL3 mice compared to vehicle (p=0.034) starting 5 weeks after treatment initiation. SM07883 was well tolerated with significant weight gain (p<0.001) over the 3-month treatment period, and reduced morbidity and mortality were observed in treated animals. Additionally, SM07883 inhibited LPS-induced TNF- α secretion in microglial cells (EC₅₀ = 71 nM) and decreased proinflammatory cytokines (IL-6, TNF α , IFN γ) in both plasma and brain lysates after IP or ICV injections in WT mice compared to vehicle. The no-observed-adverse-effect-levels (NOAELs) were established in toxicology studies up to the highest dose tested in mice and the middle dose in monkeys (30x and 5x higher AUC than the minimum efficacious dose, respectively). **Conclusion:** SM07883, a selective and potent, oral, brain-penetrant, DYRK1A inhibitor significantly reduced tau phosphorylation and decreased the effects of pathological tau overexpression and neuroinflammation resulting in improved functional endpoints compared to vehicle in mice. IND enabling, 28-day, repeat-dose toxicological studies demonstrated acceptable safety profiles with a sufficient therapeutic margin. The biochemical profile of SM07883 established in these studies, including the effects on IL-6 and GFAP, provide a basis for potential biomarker profiles for clinical trials. SM07883 is a potential treatment for AD. A phase 1 clinical trial is planned.

P106: APABETALONE, A BET BROMODOMAIN INHIBITOR, SUPPRESSES INFLAMMATORY MEDIATORS IN MICROGLIA AND VASCULAR ENDOTHELIAL CELLS THAT CONTRIBUTE TO NEURODEGENERATIVE DISEASE. Ewelina Kulikowski¹, Emily Daze¹, Sylwia Wasiak¹, Dean Gilham¹, Laura M. Tsujikawa¹, Brooke Rakai¹, Stephanie C. Stotz¹, Christopher Halliday¹, Ravi Jahagirdar¹, Norman C. W. Wong¹, Michael Sweeney², Jan O. Johansson² ((1) *Resverlogix Corp, Calgary, AB, Canada*; (2) *Resverlogix Inc, San Francisco, CA, USA*)

Background: Apabetalone is an orally available small molecule in phase 3 trials for cardiovascular disease (CVD). As an inhibitor of bromodomain and extraterminal domain (BET) proteins, apabetalone regulates gene expression through an epigenetic mechanism. Clinical trials in CVD patients and preclinical models demonstrate peripheral anti-inflammatory effects of apabetalone treatment. Systemic or localized peripheral inflammatory injury can lead to transmission of neural signals as well as infiltration of peripheral molecules and immune cells into the central nervous system (CNS). This immune-brain axis contributes to microglial pro-inflammatory activation and neurodegeneration. **Objectives:** Here we evaluated the therapeutic potential of apabetalone in pre-clinical models of neuroinflammation. We assessed responses

to apabetalone in human brain endothelial cells, microglial cells and brains of endotoxemic mice. **Methods:** The brain endothelial cell line hCMEC/D3 and primary human brain microvascular endothelial cells (HBMVECs) were stimulated with 10ng/mL TNF alpha and interferon-gamma for 4 and 24h. Mouse BV-2 microglial cells were stimulated with 100 ng/mL LPS and 5 ng/mL interferon-gamma for 24h. Changes in expression of proinflammatory genes following treatment with apabetalone were examined by real-time (RT) PCR and FACS analysis. 8 week old C57BL/6 male mice received 150 mg/kg apabetalone twice daily orally for 6 days. On day 7, mice received two doses of apabetalone 4 hours apart and 10 µg of lipopolysaccharide (LPS) was administered intraperitoneally. Mice were euthanized 24 hours post LPS. Total RNA was extracted from mouse brain tissue and gene expression was analyzed by RT PCR. **Results:** Vascular endothelial cells convey inflammatory responses from the periphery to the CNS while activated microglial cells propagate inflammation in the CNS ultimately leading to neuronal injury. Treatment of hCMEC/D3 cells and HBMVECs with TNF-alpha and interferon-gamma showed an upregulation of markers of inflammation and vascular activation such as interleukin-6, interleukin-1 beta, monocyte chemoattractant protein 1, VCAM and E-selectin. Apabetalone dose dependently opposed this induction at the gene expression level. The surface adhesion protein VCAM was also reduced. Treatment of BV-2 cells in vitro showed that apabetalone dose dependently opposed LPS and interferon gamma mediated induction of key contributors to neurodegenerative processes such as interleukin-6, interleukin-1 beta, monocyte chemoattractant protein 1, complement C3 and C1q. Peripheral LPS injection in mice leads to inflammatory responses in the CNS. In brain tissue from endotoxemic mice, apabetalone countered the upregulation of endothelial adhesion molecules E-selectin, ICAM, CCR2 and CD68, which is a marker of activated macrophages and microglial cells. **Conclusions:** In CNS cell models and inflamed mice, the epigenetic inhibitor apabetalone can counter inflammatory expression of cytokines, chemokines and markers of endothelial activation associated with neuroinflammation and cognitive dysfunction. The effect of apabetalone on cognition is currently being evaluated with MoCA in participants' ≥70 years of age enrolled in the phase 3 BETonMACE trial focusing on cardiovascular outcomes in patients with CVD and diabetes.

P107: CLINICO-RADIOLOGICAL RECOVERY OF ARIA-LIKE EVENTS IN CORTICOSTEROID-TREATED CAA-RI PATIENTS: IMPLICATIONS FOR THE MANAGEMENT OF ARIA SIDE EFFECTS OF ANTI-AMYLOID IMMUNOTHERAPY. Fabrizio Piazza^{1,2,3,4}, on behalf of The iCAβ International Network Collaborators and The CAA Study Group of the Italian Society of Neurology for dementia*, Jacopo C. DiFrancesco^{1,2,3}, Marialuisa Zedde^{1,5}, Federica Angiulli^{1,3}, Rosario Pascarella⁵, Roberto Marconi⁶, Francesco Perini⁷, Alberto Villarejo-Galende⁸, Mario Cirillo⁹, Berardino Orlandi¹⁰, Ihara Masafumi¹¹, Mehdi Touat¹², Hagiwara Yuta¹⁶, Juan F. Vázquez-Costa¹⁴, Massimo Caulo¹⁵, Shima Atsushi¹⁶, Alessia Giossi¹⁷, Ricardo Nitrini¹⁸, Massimo Musicco^{2,4} *Main Network Collaborators ((1) *The inflammatory cerebral amyloid angiopathy and Alzheimer's disease biomarkers (iCAβ) International Network, University of Milano Bicocca, Monza, Italy;* (2) *The CAA Study Group of the Italian Society of Neurology for dementia (SINdem), Italy;* (3) *University of Milano Bicocca, Monza, Italy;* (4) *National Research Council, Segrate, Italy;* (5) *Arcispedale Santa Maria Nuova-*

IRCCS, Reggio Emilia, Italy; (6) *Department of Neuroscience, Ospedale Misericordia, Grosseto, Italy;* (7) *St. Bortolo Hospital, Vicenza, Italy;* (8) *Hospital 12 de Octubre. CIBERNED, Madrid, Spain;* (9) *Università della Campania «L. Vanvitelli», Seconda Università degli Studi di Napoli, Italy;* (10) *S.S. Filippo and Nicola Hospital in Avezzano, L'Aquila, Italy;* (11) *National Cerebral and Cardiovascular Center, Osaka, Japan;* (12) *Dana-Farber Brigham and Women's Hospital, Boston, Massachusetts, USA;* Inserm U 1127, CNRS UMR 7225, Sorbonne Universités, Paris, France; (13) *St. Marianna University School of Medicine, Japan;* (14) *Instituto de Investigación Sanitaria la Fe (IIS La Fe), Valencia, Spain;* (15) *University «G. d'Annunzio», Chieti, Italy;* (16) *Kyoto University Graduate School of Medicine. Kyoto, Japan;* (17) *O.U. of Neurology, ASST Cremona, Italy;* (18) *University of São Paulo School of Medicine, São Paulo, Brazil)*

Background: Cerebral amyloid angiopathy-related inflammation (CAA-ri) (1) is an increasingly recognized condition presenting as an acute or subacute cerebrovascular event mediated by an autoimmune and inflammatory reaction against the amyloid-beta (Aβ) protein deposited in the walls of cortical and leptomeningeal vessels of CAA and Alzheimer diseases (AD) patients. CAA-ri has been demonstrated to resemble several biological, clinical, PET, and radiological similarities with the Amyloid-Related Imaging Abnormalities (ARIA) serious side effects of immunotherapy. ARIA has an incidence of up to 55% in the AD patients treated with monoclonal antibodies, and currently represent the main cause of patient dropout from clinical trials (2-6). Like ARIA, clinical symptoms of CAA-ri comprise the combination of different manifestations, varying from very-mild cognitive disturbances to rapidly progressive cognitive decline, seizures, focal neurological deficits, impaired consciousness and headache. These clinical symptoms associate with the characteristic MRI hallmarks of CAA, represented by multiple areas of cortical subcortical microbleeds (MBs) and or cortical superficial siderosis (cSS), and of active inflammation represented by white matter hyperintensities (WMH) and vasogenic oedema (VE): resembling ARIA-H and ARIA-E, respectively (5). The current lack of knowledge on the natural history of CAA-ri, and consequently on the outcomes potentially associating to medical interventions, represents a critical issue for the clinical management of patients, including the absence of specific recommendations for the treatment of ARIA in immunotherapy. Literature findings from single case reports suggest that CAA-ri is a potentially reversible condition, responsive to immunosuppressive treatments. A better understanding of the possible therapeutic interventions to mitigate ARIA may have immediate translational impact on AD clinical trials, sensibly reducing the dropouts due to ARIA. **Objectives:** The purpose of this study is to shed light on the natural history of ARIA-like, and to provide the first comprehensive long-term evaluation of post-treatment's outcomes in the largest cohort of CAA-ri patients currently available. **Methods:** In this cohort study, we reviewed all the individual case-report forms of the 150 consecutive CAA-ri patients referred to the iCAβ International Network, from January 2013 to March 2017. Cases were referred worldwide, from 25 different recruiting centres. After diagnosis (baseline), patients were visited for post-treatment evaluation of the clinical and radiological outcomes at 1.5 weeks, 3, 6, 12 and >12 months follow-up. **Results:** The mean age of onset was 72.6 years. History of cognitive impairment and ICH was reported, respectively, in 32% and 31% of the patients.

84% of CAA-ri received immunosuppressive therapies, with good clinicoradiological responsiveness in 76%. 16% showed a spontaneous recovery, while 14% were non-responders to therapy. The great majority of the patients clinically recovered within the first three months (69%). The probability of recovery increased to 77% and 80% at six months and at twelve months visits, respectively. The most frequent treatment was high dose bolus of IV corticosteroids, initiated within 30 days from onset (64%), showing a probability of 3 months clinical recovery of 76%. The probability of clinical recovery decreased to 55% in the patients that were not treated or initiated the treatment later than one month from disease onset (p=0.023). Treatment-related adverse events occurred in 6% of cases. The rate of radiological recovery was slower than that of clinical recovery, however reaching almost the same cumulative probability after one year. **Conclusion:** First-line combination therapy with 5 intravenous injections of 1g/day methylprednisolone, followed by 1mg/Kg oral prednisone and slight tapering-off, showed a good clinical and radiological recovery of ARIA-like in 76% of patients. Second-line treatments with cyclophosphamide or azathioprine are advocated in non-responders to corticosteroids. Following a consensus meeting involving members of the iCA β international Network and the CAA Study Group of the Italian Society of Neurology for dementia, we propose a firsthand expert opinion Research Algorithm to support physicians in the decision-making process for therapeutic interventions and managements of patients with CAA-ri. Based on these data, with the sake of patients' interest, we encourage Pharma Companies to explore the implementation of our Research Algorithm for the treatment of patients presenting ARIA during clinical trials. References: 1. Auriel, E. et al. Validation of Clinicoradiological Criteria for the Diagnosis of Cerebral Amyloid Angiopathy-Related Inflammation. *JAMA Neurol* 73, 197-202 (2016); 2. Piazza, F. et al. Anti-amyloid β autoantibodies in cerebral amyloid angiopathy-related inflammation: Implications for Amyloid-Modifying Therapies. *Ann Neurol* 73, 449-458 (2013); 3. Piazza, F. & Winblad, B. Amyloid-Related Imaging Abnormalities (ARIA) in Immunotherapy Trials for Alzheimer's Disease: Need for Prognostic Biomarkers? *J Alzheimers Dis* 52, 417-420 (2016); 4. Piazza, F. et al. Increased tissue factor pathway inhibitor and homocysteine in Alzheimer's disease. *Neurobiol Aging*. Feb;33(2):226-33 (2012); 5. DiFrancesco, J.C. et al. Anti-A β Autoantibodies in Amyloid Related Imaging Abnormalities (ARIA): Candidate Biomarker for Immunotherapy in Alzheimer's Disease and Cerebral Amyloid Angiopathy. *Front Neurol* 6, 207 (2015); 6. Piazza F. Reader response: A phase 3 trial of IV immunoglobulin for Alzheimer disease. *Neurology*. 2018 Jan 16;90(3):144-145 (2018). Keywords: Cerebral Amyloid Angiopathy-related inflammation (CAA-ri); Amyloid Related Imaging Abnormalities (ARIA) Immunosuppressive therapy; Corticosteroid therapy; Vasogenic oedema; Microbleeds; ICH

P108: CLINICAL PHARMACOKINETICS AND PHARMACODYNAMICS DEMONSTRATE ONCE-WEEKLY CORPLETEM DONEPEZIL TRANSDERMAL SYSTEM AS A THERAPEUTIC ALTERNATIVE TO DAILY ORAL ARICEPT. Bobby Singh (*Corium International, Inc., 235 Constitution Drive, Menlo Park, California, USA*)

Background: Aricept® (donepezil hydrochloride) is the most commonly used therapy worldwide in the treatment of Alzheimer's disease as a daily tablet. Patient adherence to therapy is poor due to the required daily administration, and

gastro-intestinal (GI) adverse effects that may be associated with the oral route of administration. The once-weekly delivery with the donepezil transdermal system (TDS) using the Corplex technology platform is expected to improve adherence by providing a convenient once-weekly patch, and potentially improve the GI tolerability profile by bypassing the GI tract. **Methods:** A Phase 1, multiple-dose, randomized crossover study in healthy subjects was conducted, with the primary objective of comparing the steady-state pharmacokinetics (PK) and pharmacodynamics (PD) of Corplex Donepezil TDS, targeted to deliver 10 mg/day of donepezil, and the oral Aricept 10 mg after several weeks of treatment. The secondary objectives were assessment of safety and tolerability (including skin tolerability). **Results:** Based on the results of our earlier single-dose Phase 1 PK study, we projected that at steady state, the maximum plasma concentration and the area under the curve of plasma concentration of donepezil with the Corplex Donepezil TDS would be similar to the same measurements of oral Aricept. The steady state PKPD data from the current clinical study is consistent with our projections, and demonstrated bioequivalence between once-weekly Corplex Donepezil TDS and oral Aricept. Sustained and controlled delivery of donepezil was observed in the plasma concentrations of all subjects treated with once-weekly Corplex Donepezil for four consecutive weeks. Subjects treated with once-weekly Corplex Donepezil experienced acceptable skin tolerability and no systemic adverse events unique to transdermal delivery. The gastrointestinal tolerability was much improved with Corplex Donepezil TDS to oral Aricept. **Conclusion:** The PKPD results from this Phase 1 multiple dose study support the feasibility of a convenient, safe and effective once-weekly dosing regimen as compared to daily oral administration.

LATE BREAKING NEWS

Theme: Clinical trials: Methodology

LBP1: HARNESSING THE POWER OF BIG DATA AND TECHNOLOGY INNOVATIONS TO ADVANCE ALZHEIMER'S DISEASE CLINICAL DEVELOPMENT. Olga Uspenskaya-Cadoz¹, Yuliya Nigmatullina², Kenneth Stanley³, Chaitanya Alamuri², Penny Randall¹, Sam Khinda³, Lanhui Wang², Mengting Yang², Carolina Rubel³, Lynne Hughes³, Tao Cao², Michelle O'Keefe², Nikhil Kayal² ((1) IQVIA CNS Center of Excellence; (2) IQVIA Analytics Center of Excellence; (3) IQVIA Project Leadership)

Introduction: The traditional approach for patient enrollment in prodromal Alzheimer's Disease (AD) population is to identify patients through direct-to-patient outreach and to target healthcare professionals (HCPs) who have historically treated AD patients who then identify potential patients from within their database. However, patients with early stages of AD can be simply missed or not even be on the radar of the AD-treating HCPs. In addition, targeting patients at early AD stages increases the pool of potential patients, which increases the demand and the need for the dementia specialist clinical evaluations and conduction of expensive and/or invasive diagnostic tests (PET, LPs). The use of big data and innovative technology solutions will provide new opportunities to optimize the clinical development process

including patient enrolment/retention and ongoing trial management. **Objective:** The objective of this abstract is to trigger discussion into innovative approaches for optimising the clinical development process in AD with specific focus into early stages of the disease. The innovative approaches include:

- Use of machine learning predictive analytics for identifying non-diagnosed prodromal AD patients in general population and support new referral networks;
- Use of patient insights to optimize protocol design and increase biomarker collection acceptability in AD trials;
- Deployment of virtual trials in AD for a more patient-centric clinical trial management approach.

Discussion: Big data and recent technology innovations are critical in allowing development of solutions that can help combat key issues in clinical development for AD. One of these solutions is the machine learning predictive model that may ingest data from various sources including claims, prescription, EMR, familial history, patient digital devices (e.g. apps sensors) to identify at risk of prodromal AD patient populations. These identified patient populations can then be linked to their HCPs for identification of the sites and physicians where these patients could be reached (see Figure 1). In addition, a predictive analytics screening tool can be embedded at the provider site to support direct screening of patients for the clinical trial. The disease risk score can be generated and viewed directly by the physician, which helps in making the decision on whether the patients should be referred for additional diagnostic tests. Additional data collected through the diagnostic tests acts as a feedback loop to validate and further train the predictive model, improving its accuracy and decreasing screening failure rate. The insights generated by the predictive model on the location of the prodromal AD patients allows for expanding AD investigator site networks by implementation recruitment strategies that are study- and site- specific. Recent innovations in app and digital device technology may provide digital biomarkers that will further screen the at-risk prodromal AD patient population. These digital biomarkers may arise from various sources to generate a longitudinal profile of patient behaviour:

- App interactions to test cognitive ability e.g. Peak, CogniSense, BrainTest.
- Wearables to monitor motion, gait, sleep, heart rate and other behavioural factors;
- Social media patterns to observe changes in network activities;
- Smart devices interaction including voice sampling, handwriting analysis, password recall etc;
- In home monitoring e.g. time in social areas, food preparation, sedentary time.

Once validated, the data collected by digital biomarker apps/ devices can be fed into the predictive model to further improve the precision of prodromal patient identification and support patient diagnosis. Highly complex, lengthy and burdensome AD disease modification trials have a strong potential to benefit from both the insights provided by study participants and from virtual trial platforms which allow study staff and study partners to bring some of the trial-related procedures directly to the patient in his or her home, including e-consent, phlebotomy, and shipping of study drug. By listening to patient feedback we can design trials that are more acceptable to participants which in turn should improve enrolment and retention rates. Additionally, endpoint data may be collected directly from the patient at home through connected devices and ePROs. Where studies typically require clinician-based assessments, bidirectional High Definition video capability can be integrated into the platform facilitating virtual interviews and ratings of subjects by a small cadre of highly trained clinicians/raters.

Conclusion: Rapid technology advancements and emergence

of predictive disease models using big data will significantly change clinical trial space in the nearest in several ways:

- Allow accurate and much earlier prodromal AD diagnosis already in the primary care setting with timely referral to expert sites for biomarker assessment and diagnosis confirmation;
- Better patient and HCP engagement (early interventions on AD risk factors, accurate early diagnosis, improved treatment plans and timely initiation of disease modifying drugs should such become available);
- Unburden patients/caregivers/sites involved in complex AD clinical trials through leveraging patient insights and implementation of virtual trial platform;
- Collect meaningful real-world data with emerging digital biomarkers allowing better understanding of long-term outcomes of disease modifying treatments.

Figure 1

Prodromal AD patient density as identified by the predictive algorithm

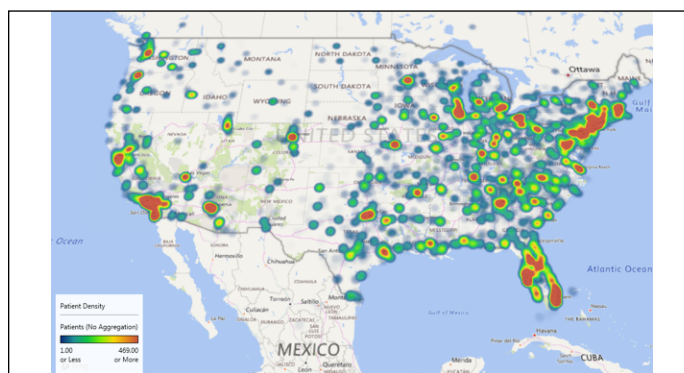

LBP2: COURSE CORRECTION IN A4: IMPLEMENTATION OF DOSE ESCALATION. Karen Holdridge¹, Roy Yaari¹, Brian A. Willis¹, Isabella Velona¹, Paul Aisen², Reisa Sperling³ ((1) *Eli Lilly and Company, Indianapolis, USA*; (2) *University of Southern California, San Diego, USA*; (3) *Brigham and Women's Hospital, Boston, USA*)

Introduction: Solanezumab 400 mg every 4 weeks (Q4W) has been studied in 3 large Phase 3 trials in Alzheimer's disease (AD) dementia. Although none of these trials demonstrated a primary outcome that was both substantial and statistically significant, an efficacy signal in the mild AD dementia population was observed. The 400--mg-Q4W dose was selected based on maximizing peripheral target engagement and the peripheral sink hypothesis, but it now appears that dosing based on peripheral engagement may have been inadequate. Accordingly, improving central target engagement may be a better strategy for dose selection. Previous studies at the 400-mg-Q4W dose suggest that higher solanezumab exposures in the central nervous system lead to higher levels of target engagement. In Phase 2 studies, patients who received higher doses of solanezumab demonstrated proportional increases in total A β CSF concentrations. Because the pharmacokinetics of solanezumab have been linear with respect to dose, and stationary with respect to time, the average plasma solanezumab concentration for equivalent cumulative doses administered weekly over 4 weeks or administered combined once every 4 weeks would be anticipated to be equivalent. Furthermore, the underlying amyloid pathology in AD begins 10 to 20 years before symptoms are evident and may be too

widespread to respond to an anti-amyloid treatment targeting monomeric amyloid-beta (A β), even at the mild AD dementia stage. The ongoing Anti-Amyloid Treatment in Asymptomatic Alzheimer's Disease (A4) study provided the opportunity to address both the "Too little?" and "Too late?" questions simultaneously. The safety profile of solanezumab at 400 mg Q4W is well characterized as acceptable and the safety profile based on the small sample of patients treated with higher doses in Phase 1 and 2 studies appeared to be consistent. Thus, the A4 study was modified to increase the dose from 400 mg Q4W to 1600 mg Q4W. The dose was also increased in the ongoing Dominantly-Inherited Alzheimer's Network-Trials Unit (DIAN-TU-001) study of solanezumab. **Objectives:** Review implementation of dose escalation in the A4 study. **Methods:** The proposed study changes were discussed among the sponsor, academic partners, FDA, NIH, and study investigators. Because of the small amount of safety data available at doses greater than 400 mg Q4W, a conservative titration schedule was developed: each participant received at least 2 doses of 400 mg Q4W, at least 2 doses of 800 mg Q4W, and 1600 mg Q4W thereafter. A quasi-Phase 1/2 study was embedded into the ongoing study in the form of a dose escalation safety cohort (DESC). The DESC comprised the first approximately 200 participants to increase dose; these participants received additional safety assessments, including additional on-site post-infusion monitoring, safety MRI, ECG, safety labs, and vital signs. Sites were retrained on the study modifications and ethics review board questions were addressed. The study safety team conducted weekly reviews of blinded data from the DESC and unblinded DESC data were reviewed by the data safety monitoring board (DSMB) at prespecified intervals, concluding when all participants in the DESC had had the opportunity to receive at least 2 doses of 1600 mg. Analysis of the cognitive primary endpoint will remain as a comparison between solanezumab- and placebo-treated groups, regardless of dose. Potential dose effects will be assessed in sensitivity analyses. **Results:** Enrollment of the DESC was completed in approximately 12 weeks (N=228). Final results from the DESC analysis were available approximately 7 months from the beginning of the dose escalation period. No new safety signals were observed in the blinded safety reviews and the DSMB recommended continuing the study, including dose escalation, with no changes. As of 24 August 2018, 970 participants (83%) have initiated dose escalation. Regular study team blinded and DSMB unblinded reviews will continue throughout the study to monitor for safety signals at all doses in the study. **Conclusions:** Ongoing AD studies can be adapted to increase study drug dose based on new scientific information, thus saving development time and resources. Based on blinded and DSMB review of unblinded safety data, the safety profile of solanezumab at a dose of 1600 mg Q4W appears to be consistent with the 400-mg-Q4W dose. NCT02008357

LBP3: DOSE ESCALATION IN THE DIAN-TU SOLANEZUMAB ARM. WAS SOLANEZUMAB IN MILD TO MODERATE AD DEMENTIA TOO LITTLE, TOO LATE? Karen Holdridge¹, Roy Yaari¹, Brian A. Willis¹, Isabella Velona¹, Susan Mills², Randall Bateman² ((1) *Eli Lilly and Company, Indianapolis, USA*; (2) *Washington University, Saint Louis, USA*)

Introduction: Solanezumab 400 mg every 4 weeks (Q4W) has been studied in 3 large Phase 3 trials in Alzheimer's disease (AD) dementia. Although none of these trials demonstrated

a primary outcome that was both substantial and statistically significant, an efficacy signal in the mild AD dementia population was observed. The 400-mg-Q4W dose was selected based on maximizing peripheral target engagement and the peripheral sink hypothesis, but it now appears that dosing based on peripheral engagement may have been inadequate. Accordingly, improving central target engagement may be a better strategy for dose selection. Previous studies at the 400-mg-Q4W dose suggest that higher solanezumab exposures in the central nervous system lead to higher levels of target engagement. In Phase 2 studies, patients who received higher doses of solanezumab demonstrated proportional increases in total A β CSF concentrations. Because the pharmacokinetics of solanezumab have been linear with respect to dose, and stationary with respect to time, the average plasma solanezumab concentration for equivalent cumulative doses administered weekly over 4 weeks or administered combined once every 4 weeks would be anticipated to be equivalent. Furthermore, the underlying amyloid pathology in AD begins 10 to 20 years before symptoms are evident and may be too widespread to respond to an anti-amyloid treatment even at the mild AD dementia stage. Thus, the negative outcome in the completed Phase 3 solanezumab studies may be due to insufficient solanezumab dose and/or targeting AD stages too far along the continuum. As an adaptive, platform trial, the solanezumab arm of the ongoing Dominantly Inherited Alzheimer's Network-Trials Unit (DIAN-TU-001) study is positioned to address both possibilities: (i) the majority of participants were asymptomatic at enrollment, representing a population earlier in the continuum of AD than previous solanezumab Phase 3 studies; and (ii) the optimal dose question may be addressed by a dose increase in the ongoing study. The safety profile of solanezumab at 400 mg Q4W is well characterized as acceptable, and the safety profile based on the small sample of patients treated with higher doses in Phase 1 and 2 studies appeared to be consistent. Thus, the DIAN-TU-001 study solanezumab arm was modified to increase the dose from 400 mg Q4W to 1600 mg Q4W. The solanezumab dose was also increased in the ongoing Anti-Amyloid Treatment in Asymptomatic Alzheimer's Disease (A4) study. **Objectives:** Review implementation of dose escalation in the DIAN-TU-001 study. **Methods:** The proposed study changes were discussed among the pharma and trial sponsor, NIH, academic partners, FDA, and study investigators. Because of the limited safety data available at doses greater than 400 mg Q4W, a conservative titration schedule was developed: each participant received at least 2 doses of 400 mg Q4W, at least 2 doses of 800 mg Q4W, and 1600 mg Q4W thereafter. In the first 20 participants to escalate dose, the first doses of 800 mg and 1600 mg were required to be administered at the study site rather than off-site by a home health nurse. These first 20 participants also underwent additional safety assessments including safety MRI, ECG, safety labs, and vital signs. Sites were retrained on the study modifications and ethics review board questions were addressed. The study safety team conducted weekly reviews of blinded data from participants who had escalated dose and unblinded data were reviewed by the data safety monitoring board (DSMB) at prespecified intervals, concluding when 20 participants had received at least 2 doses of 1600 mg. Dose escalation safety data were shared between the DIAN-TU and A4 studies in an effort to efficiently identify potential safety signals. Analysis of the cognitive primary endpoint will remain as a comparison between solanezumab- and placebo-

treated groups, regardless of dose. Potential dose effects will be assessed in sensitivity analyses. **Results:** Dose escalation (at least 1 dose of 800 mg) in the first 20 participants was completed in approximately 8 months. The final review of safety data when 20 participants had received at least 2 doses of 1600 mg was completed approximately 12 months from the beginning of the dose escalation period. No new safety signals were observed in the blinded safety reviews and the DSMB voted unanimously to continue the trial without modification. As of 17 August 2018, 49 participants (75%) had initiated dose escalation. Regular study team blinded and DSMB unblinded reviews will continue throughout the study to monitor for safety signals at all doses in the study. **Conclusions:** Ongoing AD studies can be adapted to increase study drug dose based on new scientific information, thus saving development time and resources. Based on blinded and DSMB review of unblinded safety data, at this time, the safety profile of solanezumab is sufficient to continue at a dose of 1600 mg Q4W with plans for the trial completion at the end of 2019. NCT01760005

LBP4: DOES THE US HAVE ENOUGH CLINICAL TRIALS SITES TO KEEP UP WITH THE DEMAND OF NEW CHEMICAL AND DEVICE COMPOUNDS ENTERING THE NDA? Sean Stanton¹, Dan Davis⁴, Vishnukartik Nitta², Jessica Branning², John Dwyer³, Jason Bork³, James Taylor⁵, George Vradenburg³ ((1) *LifeCore Solutions, LLC*; (2) *ClinCloud, LLC*; (3) *Global Alzheimer's Platform*; (4) *Bioclinica Research*; (5) *Independent Consultant - Caregiver*)

Background: There are approximately 31 drugs in phase 3 and 68 drugs in phase 2 development for memory impairment. It is reported that there are approximately 200 sites in the US that are capable of randomizing 25 subjects per year. The current demand for participants is approximately 25, 277 across 55 studies requiring this type of enrollment. That means we would need approximately 505 clinical trials sites capable of randomizing at least 25 subjects per year. Is it possible to meet this demand? Prior to answering this question our job was to research where in the US the population is located for people >60 years of age. We also researched where are clinical trial sites were in relation to this population. And lastly, how many of these sites have done at least 1 memory study in the last 2 years. **Objective:** To determine if the US has sites positioned in the right places to meet the demand from both the patient and the industry/NIH for Alzheimer's disease. If yes, can we increase capacity to meet the patient enrollment needs? If no, what do we need to do organically grow sites to meet this need. **Methods:** The population was surveyed using the US Census Bureau and plotted graphically using excel. The data can be seen in the graphs below. The data on the site locations was compiled through clinical trials.gov. The data on Alzheimer's sites was also collected from Clinical Trials.Gov. The data on the Global Alzheimer's Sites was supplied by GAP. Each data set was scattered plotted using excel and graphics tools. **Result:** The results are plotted on the graphs below. **Conclusions:** As seen in the scatter plots the site locations do not align cohesively with the population greater the 60 years of age. As the demands of subject enrollment increases there is further pressure on existing sites within overly saturated clinical trial site zones while other zones offer no clinical trial sites within 50 miles. This will continue to lead to low performance and delayed timelines. GAP along with other groups have started positioning itself to manage the ongoing demand from both the patient and industry

perspective. We will be further presenting more detailed data on these breaking discoveries. We will offer answers to expanding site capabilities, organically growing "black hole" zones, and also teaching sites interested in stopping Alzheimer's the dynamics to being successful in clinical trials for Alzheimer's Disease. 1Dave Morgan, MD Michigan State presents at AAIC, 2018

Figure 1
Graphs/Stats (the pictures are just zoomed in images of the same US plot)

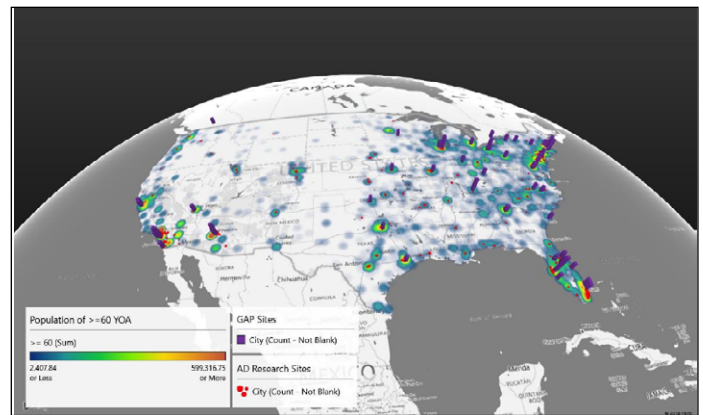

LBP5: GOAL ATTAINMENT SCALING SCORES, WITHOUT DEFINED ATTAINMENT LEVELS, WERE ASSOCIATED WITH STANDARDIZED MEASURES IN PEOPLE WITH VASCULAR AND MIXED DEMENTIA. Kenneth Rockwood^{1,2}, Justin Stanley¹, Taylor Dunn¹, Susan E Howlett^{1,2} ((1) *DGI Clinical Inc., Halifax, NS, Canada*; (2) *Dalhousie University, Halifax, NS Canada*)

Background: The use of Goal Attainment Scaling (GAS) has challenged healthcare practitioners on how best to both define patient-voiced goals that accurately portray baseline status, and to develop a full range of attainment levels for each goal area [1]. To facilitate its execution, standardized menus of goal areas and attainment levels have been used in geriatric rehabilitation and chronic diseases, including dementia. Here, we investigate the use of goal tracking software to assess the feasibility of setting goals and ranking attainment without having pre-defined attainment levels, other than as the degree of change from baseline. Previously, we had reported this trial using a Likert scoring system [2]. Here, we substituted that with the scoring used in Goal Attainment Scaling [3]. **Objectives:** Our objectives were to: 1. investigate the relationship between this modified use of GAS (mGAS) and other standardized outcome measures, 2. compare the number of goals set by domain to the standardized measures that assess those domains, and 3. assess the responsiveness of mGAS using SymptomGuide™ scoring. **Methods:** VASPECT, an open-label trial of donepezil in vascular dementia (VaD) and mixed Alzheimer disease (AD)/VaD, was a six-month study conducted between 2005-2008 at 30 Canadian primary care clinics [2]. Using the Clinical Global Impressions (CGI) of Severity, at baseline most subjects were rated with mild to moderate dementia. The primary outcome was Mini-Mental State Examination (MMSE) scores measured at three and six months. Secondary outcomes included Disability Assessment for Dementia (DAD) to measure activities of daily living, an

Table 1

Correlation matrix between select outcome measures at six months

	mGAS	Δ MMSE	Δ DAD	Δ NPI-Q	Δ NPI-Q-D	CGI-I
mGAS	1	0.37	0.30	-0.38	-0.48	-0.66
Δ MMSE	0.37	1	NS	-0.24	-0.25	-0.52
Δ DAD	0.30	NS	1	-0.22	-0.34	-0.23
Δ NPI-Q	-0.38	-0.24	-0.22	1	0.79	0.32
Δ NPI-Q-D	-0.48	-0.25	-0.34	0.79	1	0.42
CGI-I	-0.66	-0.52	-0.23	0.32	0.42	1

NS: Not significant

executive clock drawing task (CLOX) for executive function, and the brief Neuropsychiatric Inventory Questionnaire (NPI-Q) for behaviour. Personalized goals, as targets for treatment, were set at baseline using the SymptomGuide™ dementia to describe the baseline state. The library consisted of 35 goal areas, each of which included 8-12 descriptions of how those symptoms manifest. In addition, subjects could create their own goals. These goals were ranked and their reported occurrences (e.g. episodes per day) were recorded. At three and six months, subjects were shown the baseline state of each goal set and asked to rate their improvements on a 7-point scale from very much improved to very much worse. The GAS formula was applied to these ranks and ratings to assess the use of GAS without defined attainment levels. Objectives were evaluated using Pearson's correlations to assess the relationship between mGAS scores, the number of goals set, and primary/secondary outcome measures (objectives 1 and 2). Analysis of variance and Standardized Response Means (SRM) were used to evaluate the response to treatment (objective 3). To assess baseline differences, Student's t-test was used for continuous variables and Pearson's chi-squared test for categorical variables. **Results:** VASPECT included subjects with VaD (77/148; 52%) and mixed AD/VaD (71/148; 48%) with similar baseline characteristics. Compared to those with VaD, however, subjects with mixed AD/VaD were generally older (78.2 vs 73.9 years old, $p=0.005$), had worse MMSE scores (21.9 vs 24.8, $p<0.001$), and performed worse on measures of executive function (CLOX differential 3.4 vs 1.8, $p=0.009$; Phonetic Fluency 6.5 vs 8.2, $p=0.007$) at baseline. SymptomGuide™ goals were categorized into goal area domains. The number of 'Cognition' goals set was most strongly associated with worse baseline MMSE ($r=-0.32$, $p<0.001$). Similarly, baseline DAD scores were most strongly associated with the number 'Daily Function' goals ($r=-0.45$, $p<0.001$). At six months, mGAS scores were well correlated with changes in other outcome measures (Table 1). Strongest associations were seen with global change (CGI-Improvement) and change in caregiver distress (Neuropsychiatric Inventory Questionnaire [NPI-Q] Distress). Subjects showed significant improvements on mGAS (mean at three months: 52.2; and six months: 54.9; $p<0.001$) which was equally as responsive as NPI-Q (SRM mGAS=0.30, NPI-Q=-0.29) and more responsive than MMSE (SRM=0.22). **Conclusions:** By six months, mGAS scores were well correlated with change in primary and secondary outcome measures. Significant improvements in mGAS were seen as early as three months and remained as responsive as all other standardized outcome measures. Accurately defining the baseline status of goals for Goal Attainment Scaling can be used to assess efficacy without the need for defined attainment levels. Further validation in other studies is needed, but this simplification might facilitate use of highly individualized measurement of treatment efficacy. References: 1. Roberts, JC, et al. (2018). Goal Attainment Scaling for haemophilia (GAS-Hem): testing the feasibility of a new patient-centric outcome measure in people with haemophilia. *Haemophilia*, 2018;24(4):e199-e206. 2. Rockwood, K., et al. (2013). Cognitive change in donepezil treated patients with vascular or mixed dementia. *Can J Neurol Sci* 40(4): 564-71; 3. Kiresuk TJ, et al., Goal attainment scaling: A general method for evaluating comprehensive community mental health programs. *Community Ment Health J*. 1968;4(6):443-53.

LB6: CONSULTATION FOR ALZHEIMER'S DISEASE PREVENTION: AN EFFECTIVE RECRUITMENT STRATEGY FOR PREVENTIVE TRIALS. Isabelle Carrie¹, Julien Delrieu^{1,2,3}, Françoise Lala¹, Christophe Hein¹, Delphine Pennetier¹, Pierre Jean Ousset^{1,2,3}, Bruno Vellas^{1,2,3}. ((1) Gerontopole, Toulouse University Hospital, Toulouse-France; (2) Inserm Unit 1027, Toulouse, France; (3) University of Toulouse III, Toulouse, France)

It is well-known that enrolling elderly adults in clinical trials is a real challenge and requires the development of specific strategies. For the recruitment of non-demented participants in the Multidomain Alzheimer Preventive Trial (MAPT study), our study team came to elaborate numerous recruitment strategies such as general practitioners networks, health care services, medias, conferences. (Carrie et al. 2012). After including 1680 participants, the study group was well aware of the recruitment challenges particularly difficult in this population. For the new preventive trials, we opened in November 2016 a free medical consultation dedicated for all subjects interested in knowing the details of the on-going preventive research programs on either Alzheimer's disease or cognitive decline at our site. The consultation process is standardized as follows: Medical History and anamnesis (including familial history of cognitive disorder or dementia), cognitive assessment (global cognitive status – MMSE, episodic memory – FCRST), explanation of the preventive protocols (review of inclusion and exclusion criteria). In one year, 204 subjects (Mean age= 70.9; mean MMSE= 28.8) were seen by our physicians. 132 of them were eligible and accepted the information sheet for one of the on-going preventive trials at our site and 43 were randomized (21%). Most of subjects seen (57%) attended public conferences on prevention organized by our team. The consultation for Alzheimer's disease prevention allowed to 1/ sensitize the subjects to clinical research; 2/ give a quick access to preventive studies; 3/ perform a first-line cognitive assessment, 4/ enrich our research registry with an asymptomatic or paucisymptomatic population. The high rate of subjects randomized in a protocol encourages us to continue and expand this consultation dedicated to prevention. Carrie et al. (2012). Recruitment strategies for preventive trials. The MAPT study (Multidomain Alzheimer Preventive Trial) . *JNHA* 16 (4) : 355- 359.

Figure 1

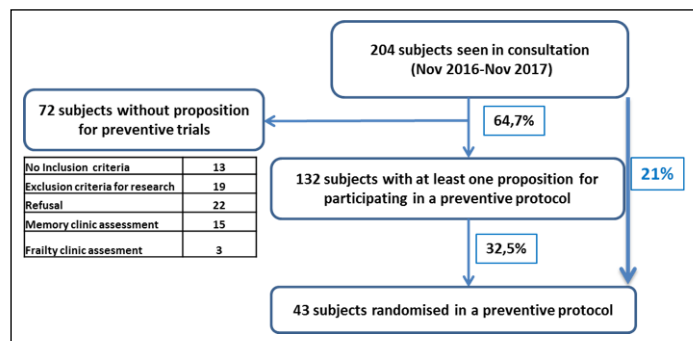

LBP7: FINDING A COMMON BASELINE: INSIGHTS FROM LATENT DISEASE-TIME PROGRESSION MODELING IN ALZHEIMER'S DISEASE. Lars Lau Raket (*H. Lundbeck A/S – Denmark*)

Background: Alzheimer's disease is slowly progressing with preclinical and prodromal phases spanning several decades before the onset of dementia. When a patient enters a clinical trial, the stage of her underlying Alzheimer's disease process is largely unknown, but may be estimated by a combination of, for example, cognitive testing, global clinical impression, and biomarker results. While such procedures of evaluating baseline disease severity are useful for creating coarse groupings of patients, the factors used to create such groupings may be affected by a wealth of factors not directly tied to the disease process, for example, intelligence, level of education, and genetics. Because cognitive decline markedly increases with disease progression, analyzing groups of patients that are not aligned in terms of disease stage will result in smeared mean progression patterns that are not representative of any one patient and reduce statistical power in group comparisons. **Objectives:** Developing a statistical framework for analyzing longitudinal data such that disease stage is explicitly handled in the modeling. Such models should enable estimation of mean progression profiles over a long-term disease timeline that are representative of the progression of an average patient. **Methods:** We developed a nonlinear mixed-effects model where individual disease stage was modeled as patient-level random time shifts relative to baseline and systematic within-patient deviations from the population disease timeline were modeled using Gaussian processes. The model was fitted using maximum-likelihood estimation. Optimization of the likelihood function automatically induce a data-driven alignment of observed patient data that predicts the most likely separation of patient-level disease stage and patient-level deviation from the mean progression curve given the variation observed in the entire population. The model was fitted on data from the Alzheimer's Disease Neuroimaging Initiative (ADNI) with longitudinal follow-up for up to 10 years. **Results:** The model was fitted on longitudinal 13-item ADAS-cog scores from 1,724 ADNI participants. The model adjusted patient-level disease-stage for baseline patient status (cognitively normal, significant memory concern, mild cognitive impairment [early/late], or dementia per ADNI definitions). The results showed a clear pattern of cognitive decline with disease time, with the process of going from cognitively normal (predicted disease time 0) to severely impaired lasting approximately 20 years (Fig. 1). To evaluate the effect of ApoE ε4 carrier status on cognitive decline

as measured by ADAS-cog, a fixed progression velocity effect of ApoE ε4 status (non-carrier, heterozygous, homozygous) was included in the model. Using the model's prediction of patient age of onset (defined as age at disease time 0), the classical ApoE ε4 gene-dose pattern of earlier onset with higher gene dose was evident (Fig. 2, left). For disease progression velocity, a clear effect of ApoE ε4 carrier status was found ($p < 0.0001$) where carriers of the ε4 allele progressed through the disease timeline at a 10% increased speed compared to non-carriers, but no difference between heterozygous or homozygous carriers was found (Fig. 2, right). **Conclusions:** A statistical modeling approach that models the major sources of variation in longitudinal data from people with Alzheimer's disease was proposed. Compared to conventional methods such as linear mixed models for repeated measurements, this clear separation of "horizontal" disease timing effects and "vertical" within-subject deviations from the mean pattern allows to accurately pose questions that relate to disease progression. This changed analytical methodology could have implications for design and power considerations in randomized controlled trials. In particular, the effects of symptomatic treatments would be expected to arise as localized vertical differences along the progression curve, whereas disease-modifying treatments would slow the rate at which the patient advanced through the progression curve. The methodology also naturally allows estimation of whether treatment effects vary across disease stages. The ability to detect differences in disease progression was illustrated by showing that ApoE ε4 carriers in the ADNI study had an increased rate of progression compared to non-carriers.

Figure 1

Observed 13-item ADAS-cog total score profiles for 1,724 participants in ADNI plotted as a function of months since baseline (left), the estimated disease stage groups given by patient baseline statuses (middle), and the predicted patient-level disease stages (right). A predicted disease time of 0 correspond to the average cognitive baseline state of the group of participants deemed cognitively normal at baseline.

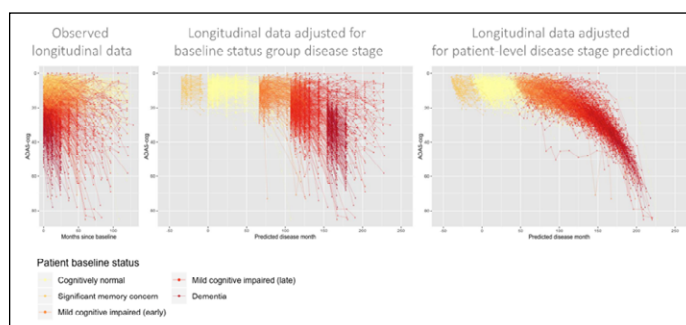
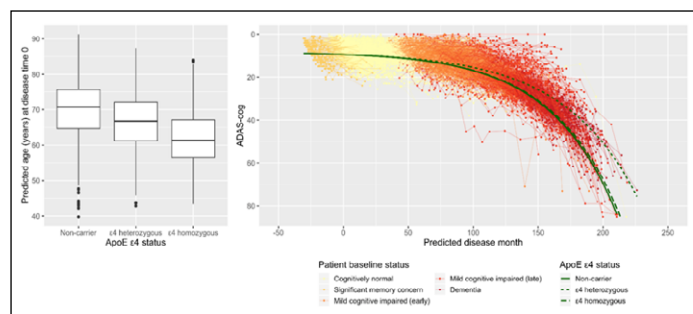

Figure 2

Predicted age at disease time 0 across ApoE ϵ 4 status (left), and aligned observations and disease progression mean curves adjusted for ApoE ϵ 4 status (right)



LBP8: THE USE OF MACHINE LEARNING ALGORITHMS IN CLINICAL TRIALS ON ALZHEIMER'S DISEASE. Delia A. Gheorghe, Sarah Bauermeister, John Gallacher (*University of Oxford, Department of Psychiatry, Oxford, UK*)

Background: Prevalence studies forecasting the burden of dementia estimate that by 2015, 46.8 million people lived with dementia worldwide. By 2030 this number is believed to increase to 75.7 million and the financial strain associated with the global cost of care may reach \$2 trillion (Prince et al., 2015). Among the known causes of dementia, Alzheimer's disease (AD) contributes to approximately 60 ~ 70% cases globally (World Alzheimer Report, 2009). Despite urgent need for new treatments, in the last two decades, new disease-modifying drugs have failed to be approved (Gauthier et al., 2016). It is therefore imperative to address the development of new treatments through comprehensive and effective clinical trial designs. The European Prevention of Alzheimer's Dementia Longitudinal Cohort Study (EPAD LCS) in alignment with the EPAD Proof of Concept (EPAD PoC) trial aim to facilitate the development of new drug treatments for the secondary prevention of AD. In this context, the EPAD LCS is of paramount importance as it will create a well-phenotyped readiness cohort and run-in data for pre-randomization purposes into the EPAD PoC. Importantly, the LCS will generate a comprehensive longitudinal dataset for AD modelling, and consequently, an individual's overall probability to develop AD could be estimated based on the accurate representation of the AD probability continuum. In EPAD, disease models will take into account the flexible contribution of three key dimensions: patient symptoms (e.g. cognition), biomarkers and traditional risk factors (both modifiable and unmodifiable) (Craig et al., 2016). **Objectives:** Given the increase of medical data being collected and the data complexity obtained from such studies like EPAD, machine learning algorithms can provide sensitive tools for interpreting datasets. Trained algorithms promise to predict the probability of an outcome at individual subject level based on multiple measures simultaneously and robust cross-validation of results (Sajda, 2006). **Methods and results:** Here we illustrate a machine learning approach adapted to distinguish individuals demonstrating mood disorder symptoms from healthy controls by focusing on differences in structural brain volume patterns. For illustrative purposes, this analysis was performed utilizing data from the UK Biobank to train and test the machine learning algorithm. Preliminary data exploration suggests that higher structural volumes in limbic, striatal, cerebellar and occipital

regions are less likely to be seen in participants presenting mood disorder symptoms. **Conclusions:** The potential significance of adaptable machine learning solutions in clinical trials is of particular importance today given the increase in the complexity of datasets. The EPAD LCS aims to generate the largest and most comprehensive probability spectrum for disease modelling, which will allow calculation of sensitive and stable predictions of AD risk. References: Alzheimer's Disease International. World Alzheimer Report 2009. London: Alzheimer's Disease International, 2009; Gauthier, S., Albert, M., Fox, N., Goedert, M., Kivipelto, M., Mestre-Ferrandiz, J., & Middleton, L. T. (2016). Why has therapy development for dementia failed in the last two decades? *Alzheimer's and Dementia*, 12(1), 60–64; Prince M, Wimo A, Guerchet M, Ali GC, Wu Yutzu, Prina M. World Alzheimer Report 2015. The global impact of dementia: An analysis of prevalence, incidence, cost and trends. London: Alzheimer's Disease International, 2015; Ritchie, C. W., Molinuevo, J. L., Truyen, L., Satlin, A., Van der Geyten, S., & Lovestone, S. (2016). Development of interventions for the secondary prevention of Alzheimer's dementia: The European Prevention of Alzheimer's Dementia (EPAD) project. *The Lancet Psychiatry*, 3(2), 179–186; Sajda, P. (2006). Machine Learning for Detection and Diagnosis of Disease. *Annual Review of Biomedical Engineering*, 8(1), 537–565.

LBP9: PREDICTING CEREBRAL AMYLOID STATUS AND COGNITIVE PERFORMANCE IN COGNITIVELY NORMAL ADULTS. Alette Wessels¹, Adrian Schembri², Pav Kalinowski², Reisa Sperling³, Roy Yaari¹, Paul Aisen⁴, David Barfield¹, Scott Andersen¹, John R. Sims^{1,4}, Paul Maruff² ((1) *Eli Lilly and Company, Indianapolis, IN, USA*; (2) *Cogstate Ltd, New Haven, Connecticut, CT, USA*; (3) *Center for Alzheimer Research and Treatment, Brigham and Women's Hospital, Harvard Medical School, Boston, MA, USA*; (4) *Alzheimer's Therapeutic Research Institute, University of Southern California, San Diego*)

Background: In cognitively normal (CN) older adults, APOE4 allele carrier status, increasing age, and their combination increases risk for elevated cerebral amyloid (AB+) which is associated with impaired cognition. However, as the sample sizes in biomarker studies of CN older adults have been relatively small, these risk estimates remain variable. Furthermore, these studies have not provided sufficient power to understand the extent to which demographic risk factors in Alzheimer's disease (AD) could influence such relationships early in the disease. Additionally, the influence of APOE4 carrier status on cognitive impairment in CN older adults independent of AB+ remains unclear. **Objectives:** To determine the risk of APOE4 status, age and sex on AB status and the risk of AB status, APOE4 status, age, sex and education on cognitive performance in CN older adults. **Methods:** The A4 study tests the hypothesis that targeting soluble AB levels will slow cognitive decline in older adults (age \geq 65 years) with preclinical AD. CN adults were screened using cognitive assessments and florbetapir PET. For the current analysis, an SUVR cut point of \geq 1.07 was used to define subjects that were amyloid positive or at risk for further amyloid accumulation (AB+ = SUVR \geq 1.07; 19 centiloids). Of note, this is a lower threshold of defining AB+ than what is used in the inclusion criteria in the A4 Study. The current analysis was conducted in 4418 adults at the screening visit 1 assessment where APOE4 status, age, sex, and education level and Cogstate Brief Battery (CBB) scores as a measure of cognition were collected. **Data analyses:** The CBB

yields primary performance measures for each of the four tests (Detection, Identification, One Card Learning and One Back) and two composite scores (Psychomotor/Attention (PSY) and Learning/Working Memory (LWM)). Descriptive statistics were computed between each clinical and demographic variable and AB status. APOE4 status was collapsed to carrier (APOE4+) or non-carrier (APOE4-). AB status (AB+, AB-), APOE4 status and sex were modelled as categorical variables. Age, education and the cognitive scores were treated as continuous measures. Risk for AB+ from APOE4, age and sex was determined using logistic regression. Associations between AB status, APOE4 status, age, sex and education in predicting cognitive performance in this cognitively asymptomatic adult sample were examined using forward hierarchical regression analysis. **Results:** Of the sample, 2657 were AB- (60.1%) and 1761 AB+ (39.9%). 1393 (31.5%) were APOE4 heterozygous and 139 (3.1%) were homozygous, yielding 34.7% APOE4+ carriers in the sample. Univariate differences between AB+ and AB- were observed for age ($p < .001$, $d = 0.18$), APOE4 status ($p < .001$) and the CBB LWM composite ($p < .001$, $d = -0.16$), but not for education ($p = .52$, $d = 0.02$), sex ($p = .11$) or the CBB PSY composite ($p = .82$, $d = 0.01$) (Table 1). Risk of AB+ from APOE4 status, age and sex, was determined with logistic regression analyses. It yielded an AUC of 0.654 when APOE4 status (OR=3.90; 95%CI 3.42 – 4.45) was considered in isolation. This increased to 0.690 with the addition of age (OR=1.06; 95%CI 1.04 – 1.07) and increased slightly to 0.693 with the addition of female sex (OR=1.22; 95%CI 1.07 – 1.39). The stepwise regression analysis indicated that AB status was unrelated to performance on the PSY composite ($p = .82$). In regards to LWM, the first step in the model indicated that AB status was related to LWM score ($p < .001$), explaining 0.58% of the variance. Variance explained in LWM score was increased to 4.01% with the addition of demographic characteristics (age ($p < .001$), education ($p < .001$) and sex ($p = .51$)). Whilst AB status remained significant ($p < .001$) in this final step, ApoE4 status ($p = .53$) was not a significant predictor. **Conclusion:** APOE4+ was the greatest independent predictor for AB status. Albeit with small effects, AB status, age, and education (but not APOE4 and sex) were significant predictors of performance on memory-based tests among this cognitively normal older adult sample.

Table 1

Summary clinical and demographic characteristics across AB status

	AB+ N=1761	AB- N=2657	p
	Mean (SD)	Mean (SD)	
APOE4 Carrier n(%)	936 (53.2%)	596 (22.4%)	< .001
Age (years)	71.35 (4.87)	70.50 (4.53)	< .001
Gender n(%)			
Male	690 (15.6%)	1105 (25.0%)	0.11
Female	1071 (24.2%)	1552 (35.1%)	
Education (years)	16.62 (2.82)	16.56 (2.84)	0.52
Psychomotor	96.47 (8.93)	96.41 (8.72)	0.82
Function/Attention*			
Learning/Working Memory*	100.43 (8.24)	101.72 (8.26)	< .001

*Psychomotor Function/Attention = average of the standardized Detection and Identification scores; Learning/working memory = average of the standardized One Card Learning and One Back scores; * = mean score = 100 and SD score = 10 because the mean and SD of the controls was used to standardize the data for each individuals performance on each cognitive task.

LBP10: NOVEL PATIENT IDENTIFICATION AND PRE-SCREENING MODEL IMPROVES PATIENT RECRUITMENT AND RETENTION AND REDUCES SCREEN-FAILURE RATES FOR AD CLINICAL TRIALS.

Lucianne Dobson, Miguel Rosa Grilo, Catherine Mummery (Dementia Research Centre, National Hospital for Neurology and Neurosurgery, Queen Square, London, UK)

Background: Rapid and appropriate recruitment of participants is essential for the successful execution of clinical trials in Alzheimer’s disease (AD). If recruitment numbers are insufficient and/or eligibility criteria are not meticulously adhered to, accurate conclusions cannot be drawn and potentially effective therapies can fail to meet clinical endpoints due to being underpowered. Many of the costs incurred by clinical trials are due to inefficiencies in patient recruitment and retention. According to the FDA, 80% of all trials are delayed at least one month because of unfulfilled enrolment and more than 2/3 trial sites fail to meet their enrolment goals. AD trials in prodromal and early stage patients are also particularly vulnerable to high screen-failure rates, a costly and highly relevant theme considering current and pipeline trials aiming at this therapeutic window. **Objectives:** To improve site-led recruitment and screen-failure rates for clinical trials in AD and dementia by developing a novel patient identification and pre-screening model. **Methods:** Information relating to sources of patient identification, recruitment strategies and pre-screening activities was collated from recruitment data sources across three interventional (IMP) and eight observational clinical trials in AD and dementia at the Dementia Research Centre (DRC), National Hospital for Neurology and Neurosurgery, London UK. The efficiency of individual recruitment sources was determined and weaknesses in recruitment and pre-screening activities following patient identification were identified. Recruitment and pre-screening strategies were adapted accordingly and analysed against recruitment, enrolment and screen-fail statistics for the twelve aforementioned studies over a 3.5 year period (Jan 2015 - Jun 2018). This allowed for accurate monitoring of any implemented changes and highlighting of successful adaptations. A final patient identification, recruitment and pre-screening model was developed and is presented below as a flow-chart of activities, also including our current statistics for Jan-Jun 2018. **Results:** The most efficient sources of recruitment were via the Cognitive Disorders Clinics, Join Dementia Research (JDR) website and referrals across research teams within the department. Self-referrals and referrals from external clinicians or support groups were the most inefficient sources. Following adaptations to the patient identification, recruitment and pre-screening processes, there was a significant increase in identification of patients and recruitment to studies (800% increase in patient identification and 430% increase in patient enrolment 2015-2018). The efficiency of recruitment via clinics was improved: in 2018 80% patients involved in studies were identified through clinics, compared with 75% in 2017 and 52% in 2015-2016. This has resulted in clinic recruitment becoming the most efficient recruitment source for studies across the DRC: 47% patients identified through clinics have screened for an IMP trial or have participated in an observational study at the DRC in 2018 and 1/3 of our patients are now involved in research. Patients identified by referrals across research teams within the DRC has also improved, resulting in this type of patient identification being the second most efficient recruitment source in 2018: 25% patients identified

were recruited to a DRC study in 2018. Implementation of the final patient identification, recruitment and pre-screening model in Sep 2017 resulted in an increase in the number of patients identified for research, the number of patients recruited to DRC studies and in efficiency of recruitment across the DRC. Our site observational studies were failing to meet recruitment targets for observational studies in 2016 and early 2017 and are now recruiting ahead of target in 2018. In 2015-2016 our IMP trials were meeting recruitment targets and in 2017-2018 we are exceeding them (e.g. 15 patients were recruited for the Biogen ENGAGE trial, 150% of the original enrolment target). Utilisation of our model has also been consistently shown to significantly decrease screen-failure rate in AD clinical trials (e.g. IONIS MAPT for which our current screen-failure rate is 40% whilst the rest of Europe and Canada have an average screen-failure rate of 70%). Furthermore, for all the AD IMP trials currently running at our site, there is a 100% post-randomisation patient retention rate. **Conclusions:** We have developed a novel patient identification and pre-screening model which we have shown to reliably and consistently increase patient identification numbers, improve patient recruitment and retention and decrease screen-failure rates for interventional and observational clinical trials in prodromal and mild AD and dementia. Implementation on a wider scale could significantly reduce costs and delays incurred by the majority of AD clinical trials as a consequence of unmet recruitment targets and high screen-failure rates. The recruitment of more suitable patients to such studies also improves patient retention and will likely produce more meaningful data for the appropriate assessment of potentially effective therapies. Our model could be easily rolled out to other sites conducting AD clinical trials and we expect implementation of the programme to have most benefit at sites that have access to AD and dementia patients through attendance at specialist clinics.

LBP11: DELIVERY OF A PATIENT FOCUSED IN-TRIAL ONLINE COMMUNITY IN A MULTI-YEAR ALZHEIMER'S DISEASE STUDY. Adam Butler, Denis Curtin, Mackenzie Johnson, Jeff Lee (CRF Bracket, Arlington, VA, USA)

Objective: Deliver a digital community to support patient and study partner engagement and retention in a multi-year Alzheimer's disease (AD) study. **Background:** Patient engagement in clinical research is a key challenge in all studies but is magnified in long term, multi-year studies with infrequent study visits. Digital communities are valuable sources of information and support for patients across disease areas. However, due to the limitations of study protocols and maintaining the unbiased, blinded needs in clinical research, the development of patient communities in ongoing trials largely remains an untapped opportunity for improving engagement and retention. **Methods:** The needs and interests of patients were developed via interview and Alzheimer's disease demographic market research and were deployed in the design and features of an online, digital community. This study included trial sites in several countries thereby requiring additional cultural considerations to be addressed. To protect the integrity of the trial, members of participating Institutional Review Boards (IRB) and study site staff members were consulted, and their feedback was included in the design and regular updates to the community. Due to the ongoing status of the study at the time of community creation, patients and their study partners were securely enrolled in the community via site visit and direct communication. Patients and partners who joined the community were offered new content tailored to their interests bimonthly and periodic communications to reengage community members. **Results:** The technology driven approach to engage study members and foster community behaviors yielded an online portal for patients, study partners, and site staff. Using multiple outreach and opportunity communication techniques, over twenty percent (498/2452) of study patients and partners opted in to enroll in the online community built to promote community behavior elements of connectedness, member influence, and shared experience. Engagement was optimized by enabling members to tailor the content and their community experience through portal personalization resulting in almost twenty-nine thousand (28,935) community visits over 26 months. Community members averaged four unique page visits per portal session. The duration of each portal session was greater than three minutes on average but was likely longer since linked external content took the study member to a non-community page. Forwarding highlighted content to study partners or saving noteworthy topics to a member's favorites were among the social media features most used by the study community but no direct contact between patients was permitted thereby maintaining study integrity and blinding. Outreach to study members consistent of email and SMS messages that alerted patients and study partners to community content updates and examples of new information. The impact of these communication campaigns increased member visits by an average of over 50% to as high as 92%. **Conclusion:** The rise and continued growth of digital patient communities directed by patient interest and contribution demonstrate both utility as a resource and engagement for members where they find reliable information and support. These communities are social by design, enabling the exchange of ideas and messages intended to further the shared experience of community members. Developing a patient community

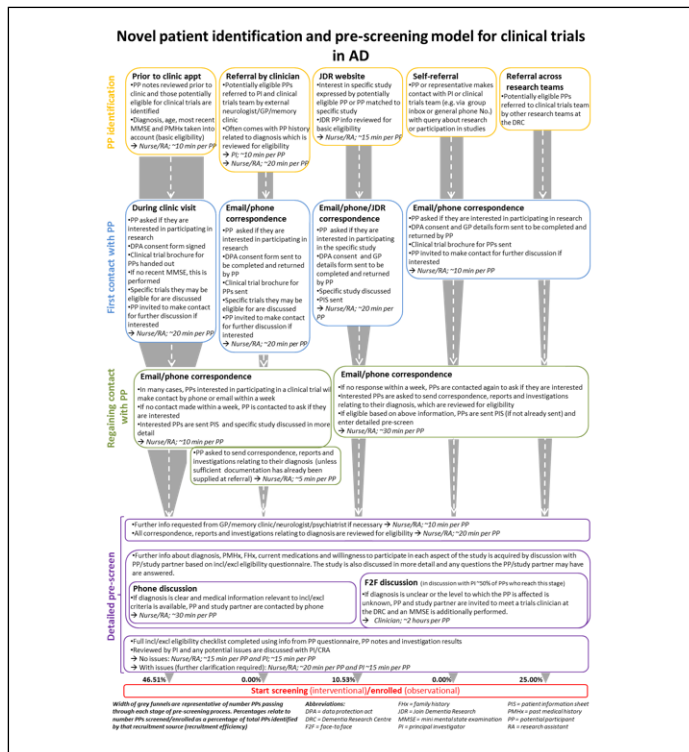

within the restrictive framework of an ongoing clinical trial presented a multitude of unique challenges including maintaining blinding, legal and regulatory limits, and IRB guidance for all patient facing materials. The in-trial community website launched for patients, their study partners, and study site staff members addressed these challenges and identified a unique methodology for cultivating patient engagement in a multi-year Alzheimer's disease trial. The large number of community visits, number of pages viewed, and time spent are positive indicators of study member interest in the content, and potentially the community experience, offered in this trial. The influence of the community on trial retention will also be examined in the coming months.

LBP12: MULTI-CROSSOVER RANDOMIZED CONTROLLED TRIAL DESIGNS IN ALZHEIMER'S DISEASE. Steven E. Arnold¹, Rebecca A. Betensky² ((1) *Massachusetts General Hospital and Harvard Medical School, Boston, USA*; (2) *Harvard T.H. Chan School of Public Health, Boston, MA*)

Background: Conventional parallel group randomized controlled clinical trials (RCT) in Alzheimer's disease (AD) are too large, long, expensive and insensitive to clinical change to meet the urgent need for an effective treatment. While providing good evidence for a treatment's benefit, parallel group RCTs in AD must have very large samples and broad measures of change to accommodate the marked heterogeneity of demographics, genetics, symptoms, pathophysiologies, comorbidities and rates of progression. **Objectives:** To consider an alternative trial design that more efficiently evaluates the efficacy of a therapeutic intervention in AD and related disorders. **Methods:** Multi-crossover, placebo-controlled, double-blind RCTs, including those with sample sizes as small as a single subject ("N-of-1"), are robust designs wherein subjects serve as their own controls in repeated blocks of randomly sequenced crossover treatments. **Results:** Heterogeneities are inherently controlled and the sensitivity, specificity and clinical relevance of outcomes can be enhanced further by including personalized outcome measures for each individual. Multi-crossover N-of-1 RCTs enable unbiased estimation of efficacy for single subjects, and joint analysis of multiple N-of-1 trials enables estimation of efficacy for populations with much smaller sample sizes than those needed in conventional parallel group studies. It is important to identify carryover effects and natural history time trends to achieve unbiased estimation and testing of the treatment effect. **Conclusions:** We assert that in AD, multi-crossover RCTs offer many advantages over standard parallel group trials for drugs or other treatments with suitable mechanisms of action, pharmacokinetics and pharmacodynamics; despite the fact that they are almost never conducted. They may be especially useful for therapies directed at symptomatic improvement of cognitive and neuropsychiatric symptoms, but also can be used in early phase studies of disease modifying treatments with biomarker outcome measures.

Theme: Clinical trials: Results

LBP13: COGNITIVE AND MOBILITY TRAINING AS PREVENTIVE MEASURES IN COGNITIVELY HEALTHY PATIENTS AND PATIENTS WITH MCI. Carine Federspiel^{1,2}, Elisabeth Bourkel¹, Jean-Paul Steinmetz^{1,2} ((1) *Centre for memory and mobility, ZithaAktiv, Luxembourg*; (2) *ZithaSenior, Research&Development, Luxembourg*)

Background: Both cognitive and physical training have a positive impact on cognitive and mobility functions of elderly people. **Objectives:** The aim of the present study is to further clarify the impact of structured cognitive and physical training programs on cognitive and mobility functions in healthy patients and in patients with MCI. **Methods:** The participants (N = 109, age mean = 77.4 years) either partook in a 12-week (1) mobility training program, (2) cognitive training program or (3) combined cognitive and mobility training program. The mobility training program focuses on the training of balance, endurance and muscular strength. The cognitive training promotes cognitive flexibility, attention and language. Based on their MMSE-Scores, participants were divided in a (1) cognitive healthy group (MMSE ≥ 27) and (2) a MCI group (MMSE < 27 points). Different mobility indicators (i.e. gait performance and risk of falling), cognitive functions (i.e., MMSE, attention tests) and self-rated health status were measured before and after the completion of the training programs. **Results:** Results are indicative of an improvement in cognitive and mobility functions as well as a higher self rated health status for both healthy elderly people and people with MCI. Results show that preventive measures are more pronounced in healthy elderly people. **Conclusion:** The discussion of the findings focuses on the positive influence of structured and multimodal preventive training programs in both older healthy adults and people with MCI.

LBP14: EVIDENCE OF SUSTAINED LOW DOSE BRYOSTATIN EFFICACY FOR TREATMENT OF ALZHEIMER'S DISEASE: CONSISTENCY OF MULTIPLE EVALUATION ANALYSES. Daniel Alkon¹, LJ Wei², Richard Thompson³ ((1) *Neurotope, Inc*; (2) *Harvard University* (3) *Johns Hopkins University*)

Background: Neurotope's Phase II trial of Bryostatin-1 to treat moderate to severe Alzheimer's disease (AD) was an exploratory, multiple dose trial of a drug with novel mechanisms of action – synaptogenesis and anti-apoptosis. **Objective:** This study was designed to explore safety and efficacy for the treatment of cognitive deficits in moderate to severe AD patients measured by changes in Severe Impairment Battery (SIB) scores. **Methods:** The Full Analysis Set (mITT – see below), as well as the Completer Analysis Set (CAS), were each pre-specified in the Statistical Analysis Plan (SAP) as alternative means to assess the primary, secondary, and exploratory efficacy endpoints for moderate to severe AD patients. The primary endpoint was quantified for both the mITT patients and patients who completed the full dosing schedule at 11 weeks, and had a completed outcome measure at the 13-week time point (CAS patients). Similarly, secondary endpoints at 5, 9, and 15 weeks were evaluated in patients who completed the 11-week drug regimen with SIB outcomes at these time points. The initial 147 enrolled patients were evenly distributed among three arms (1:1:1): placebo (n=50 at

start of trial, 42 completed trial), 20 μ g (n=49 at start of trial, 38 completed trial), 40 μ g (n=48 at start of trial, 33 completed trial). Each patient received 7 doses of either placebo or Bryostatin-1 over 11 weeks: (0, 1, 3, 5, 7, 9 and 11 weeks). In the analysis of a pre-specified exploratory interaction, the use of memantine as a concurrent, standard-of-care drug regimen is described here in more detail. **Results:** Safety: The lower dosing protocol (24 μ g for the first two weeks, followed by 20 μ g every other week for 7 weeks) demonstrated safety minimally different from the placebo protocol. Efficacy: In these efficacy analyses, the Completers showed evidence of improvement in the SIB that was at week 13 ($p < 0.07$), and evidence of improvement for the secondary endpoint of week 5 ($p < 0.016$). Furthermore, for a pre-specified exploratory endpoint at week 15, SIB improvement was at the $p < .029$ in the Completer group, providing evidence of sustained improvement up to 30 days post-last dose at 11 weeks. The mITT group showed evidence of improvement at week 5. The 40 μ g cohort patients showed no efficacy, reduced safety, and increased drop-out rates and was considered to correspond to higher doses measured in vitro that cause downregulation of PKC rather than activation. Exploratory Analysis: A pre-specified exploratory analysis of the potential Bryostatin-1 interaction with standard of care therapy (donepezil or memantine) was subjected to thorough statistical analyses. This analysis provided evidence of clinical improvement of Bryostatin-1 in the absence of memantine for patients with moderate to severe AD. Patients on Bryostatin-1 in the absence of memantine showed evidence of sustained SIB improvement over baseline compared to placebo (> 6.30 points). In addition to direct t-test comparisons, a Wilcoxon test comparison, and a Wei-Lachin analysis, Trend Analysis provided additional evidence of efficacy across all time points. SIB trends were examined to determine an increase or decrease in SIB scores over time. These trend analyses performed on the repeated SIB measures used mixed, random effects models that treated time as a continuous variable. No endpoints were imputed in these pre-specified exploratory analyses of patients not taking memantine due to a low loss to follow-up rate. Individual patient trends over time revealed that 15 out of 16 patients (94%) in the 20 μ g Bryostatin-1, non-memantine group showed improvement in SIB by the end of the trial. In contrast, only 7 out of 14 patients (50%) in the non-memantine placebo group showed SIB improvement at the end of the trial, suggesting chance SIB improvement among placebo patients. The difference in the percent of AD patients improving between groups was statistically significant ($p < 0.007$, chi-square test). Analyzing the data using a mixed model revealed that the SIB values did not increase over time for non-memantine placebo patients, resulting in slopes that were not statistically different from zero (e.g. 'zero-slope'). In contrast, the mean SIB slopes determined by MMRM analysis for the 20 μ g Bryostatin-1 patients not on memantine therapy were highly statistically significant at the $\alpha = 0.05$ level, giving a slope (95% CI) = 0.36 (0.08, 0.64) SIB points per week in the random intercept model (two-sided $p < .001$), and a slope (95% CI) = 0.38 (0.18, 0.59) points per week in the random intercept and slope model (two-sided $p < .001$). The interaction terms, which indicate a difference in treatment effect by arm, were significant for both MMRM models. **Conclusion:** The consistency of these multiple analyses provided strong evidence of a treatment effect for the 20 μ g Bryostatin-1 protocol in advanced AD patients in the absence of memantine. Fig. 1 Model for Repeated Measures (MMRM) models with random intercepts.

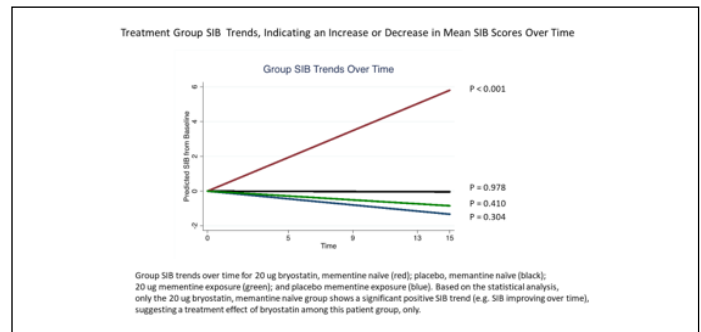

LBP15: ENTEROVIRUS MIGHT BE INVOLVED IN ALZHEIMER'S DISEASE - RESULTS FROM A PHASE IIA TRIAL EVALUATING APOVIR, AN ANTIVIRAL DRUG COMBINATION. Lars-Olof Wahlund¹, Lars Lindqvist², Mikael Åström³, Jacob Westman⁴, Roger Bullock⁵, Suzanne Hendrix⁶, Nina Lindblom⁴ ((1) Karolinska University Hospital, Huddinge, Sweden; (2) Karolinska University Hospital, Huddinge, Sweden ;(3) StatCons, Limhamn, Sweden; (4) Apodemus AB, Solna, Sweden; (5) Roger Bullock Consulting Ltd, Swindon, UK; (6) Pentara Corporation, Salt Lake City, - USA)

Background: Several infectious agents have been pointed out as potential etiological factors in Alzheimer's Disease (AD). To date no specific infectious agent has been clearly linked to the disease. We hypothesize that enterovirus might be an etiological factor involved in the development and/or progression of AD. Enterovirus, which belongs to the picornaviridae family, is present throughout the world. Each year, enterovirus is estimated to cause about 1 billion infections in the US alone. We believe that anti-enteroviral agents can be used in AD to decrease the rate of AD progression by (i) preventing additional infections from occurring (ii) treating a persistent low grade infection. To our knowledge, this is the first clinical trial evaluating the effect of antiviral treatment on AD progression. **Objective:** The current trial evaluated the safety and efficacy of Apovir, a combination of the two antiviral agents, pleconaril and ribavirin, on AD. Pleconaril is an unapproved anti-enteroviral agent originally developed for treatment of common cold. Ribavirin is an antiviral drug effective against several viruses and approved for treatment of hepatitis C. In this trial ribavirin was given primarily to prevent the development of viral resistance towards pleconaril. **Methods:** This was a randomized, double-blind, placebo-controlled trial. Sixty-nine patients, 60-85 years of age diagnosed with AD and a MMSE score of 21-27 were randomly assigned and treated with Apovir (pleconaril 600 mg/day and ribavirin 600 mg/day and reduced to 400 mg/day during the trial) or matching placebos for 9 months and thereafter followed until 12 months after end of treatment. The trial was divided in two parts the "main part" comprising the screening and treatment period and the 1 month follow-up visit and the "follow-up part" comprising the 6 and 12 month follow-up visits after end of treatment. During the "main part" of the trial safety, cognitive function (ADAS-cog 11, CDR, MMSE and AQT), pharmacodynamic biomarkers (tau, P-tau and beta amyloid), and Apovir plasma and cerebrospinal fluid concentrations were assessed. During the "follow-up part", cognitive function (ADAS-cog) was assessed. It became evident during the trial that there was an unexpectedly high drop-out rate due to adverse events. The safety board raised no safety concerns but, ribavirin has a well-known side effect profile and the adverse events reported in the trial indicated that the

compromised tolerability was probably largely due to ribavirin. Therefore, we decided to decrease to daily dose of ribavirin from 600 to 400 mg/day for all patients, aiming to improve the tolerability of the Apovir. This decision was implemented when about half of the patients had been randomized. Statistical analyses were made on data from the "main part" of the trial. In addition, post-hoc analyses were conducted to evaluate the effect of drop-out in the Apovir group. **Results:** Out of 69 patients included in the trial 62 had efficacy data at 3 months and were included in the Full Analysis Set (FAS), defined as the primary analysis set for the efficacy analyses. The tolerability of Apovir was found to be compromised. The drop-out rate was considerably larger in the Apovir group, during the "main part", 18 (51.4%) patients discontinued the trial prematurely in the Apovir group as compared to 4 (11.8%) patients in the placebo group. Also, the frequency, severity and seriousness of adverse event were more pronounced in the Apovir group. The primary endpoint, to show a difference in change from baseline to 9 months between groups in ADAS-cog total score, was not met ($p=0.1809$). However, secondary endpoints showed effect assessed by both ADAS-cog and CDR-SB. The results showed an improvement in ADAS-cog in the Apovir group in whereas no effect was observed in the placebo group. Further, there was a significant difference between groups favoring Apovir in patients with a clinically relevant change in ADAS-cog (defined as a 4-point change). CDR-SB data showed a worsening in the placebo group but no effect in the Apovir group. MMSE results indicated no consistent difference in effect between treatment groups. During the long-term follow-up part, efficacy assessed by ADAS-cog showed a comparable mean increase in total score between groups. The post-hoc analyses made to assess the effect of drop-out in the Apovir group suggest that the effect of Apovir can't be explained by the high drop-out rate alone and that there seems to be a true effect of Apovir. **Conclusion:** The trial did not meet its primary endpoint and although some efficacy trends were observed the trial is judged as inconclusive. The interpretation of the results was complicated by the large number of patients in the Apovir group who prematurely discontinued the trial. Additional trials are needed to confirm the potential benefit of Apovir for treatment of AD. Further, the safety of Apovir, and its respective components, needs to be clarified.

LBP16: A RANDOMIZED, PLACEBO CONTROLLED, REPEAT DOSE PHASE 1 STUDY OF COR388 IN OLDER HEALTHY VOLUNTEERS AND PATIENTS WITH ALZHEIMER'S DISEASE. Samer Kaba¹, Casey Lynch¹, Mark Ryder², Ira Goodman⁴, Steve Thien⁴, Steve Dominy¹ ((1) Cortexyme, S. San Francisco, CA; (2) UCSF, San Francisco, CA; (3) Bioclinica, Orlando, FL; (4) Pacific Research Network, San Diego, CA)

Background: COR388 is a novel bacterial protease inhibitor being developed for the treatment of Alzheimer's disease (AD). The mechanism of action is based on the discovery of *Porphyromonas gingivalis* (Pg) in the brain and cerebral spinal fluid of AD patients. Toxic proteases from the bacterium, called gingipains, were also identified in the brain of AD patients and levels correlated with tau and ubiquitin pathology. Oral infection of mice with Pg resulted in brain colonization and increased production of A β 1-42. Gingipains were neurotoxic in vivo and in vitro, exerting detrimental effects on tau and loss of hippocampal neurons. Cortexyme designed and synthesized small-molecule gingipains inhibitors to block this neurotoxicity.

Gingipain inhibition reduced the bacterial load of Pg in the brain, blocked A β 1-42 production, reduced neuroinflammation and rescued neurons in the hippocampus. COR388, a lysine-gingipain inhibitor, was selected to progress to human trials based on its safety, efficacy, and pharmacokinetics in preclinical studies. In a first in-human single ascending dose study, COR388 was safe and well tolerated in doses ranging from 5 to 250 mg. Based on these results, we initiated this repeat dose study. **Objectives:** • To assess the safety, tolerability, and pharmacokinetics of repeated doses of COR388 given for 10 days in older healthy volunteers, and for 28 days in a cohort of mild to moderate AD patients. • To assess exploratory biomarkers in a cohort of mild to moderate AD patients. **Methods:** A total of 33 subjects were enrolled in this study. Subjects in each cohort were randomized to receive COR388 HCl capsules or matching placebo. Cohorts 1-3 enrolled healthy volunteers 55-80 years of age with no evidence of dementia or major illnesses. Subjects were housed in a phase 1 unit for 12 days for close safety monitoring. Subjects in Cohorts 1, 2 and 3 received 25, 50, and 100 mg of COR388 or placebo q12h for 10 consecutive days. Multiple blood samples were collected on day 1 and day 11 for measurements of plasma levels of COR388. Cohort 4 enrolled AD subjects 55-85 years of age in good general health otherwise. Major inclusion criteria included having probable AD based on NINDS-ADRDA criteria, baseline MMSE between 14 and 25, screening MRI compatible with AD, and no other cause of dementia. Subjects were allowed to stay on stable doses of background medications including symptomatic treatments of AD. Subjects in this cohort received 50 mg of COR388 or placebo q12h for 28 days as outpatients and returned to the clinic for weekly safety assessments. A lumbar puncture was performed on Days 1 and 28. A CSF catheter was placed on Day 1 in patients enrolled at the designated PK site where repeated blood and CSF samples were collected during the 6 hours post-dose for measurements of COR388 levels. **Results:** A total of 24 subjects were enrolled in cohorts 1-3, 55% male with a mean age of 60 years (55-70). Eighteen subjects received COR388 and 6 received placebo. All but 1 subject completed the planned 10 days of treatment. COR388 was absorbed rapidly ($T_{max} = 0.5-1.5$ hours) and therapeutic levels in animal models were achieved. The apparent half-life ($T_{1/2}$) at steady state was 4.5-5 hours. COR388 was safe and well tolerated with infrequent and transient adverse events that were mild in severity. The most common adverse events in the active treatment group were diarrhea and dizziness (1 of each at 50 and 100 mg). No dose limiting toxicity was identified and no serious adverse events were reported. There were no clinically meaningful trends in laboratory tests, ECG, or vital signs. Nine subjects were enrolled in the AD cohort (Cohort 4), 56% male with a mean age of 73 years (59-84). This cohort is still ongoing at this time and topline results will be presented at CTAD. To date, 6 subjects have completed the study. Transient adverse events have been reported in 5/6 subjects and were mild to moderate in severity. COR388 was detected in human CSF at ratios consistent with that in other species. No adverse event occurred in more than one subject, and no serious adverse events were reported. Exploratory biomarkers will be analyzed. In addition, measurements of cognitive functions were conducted, primarily for safety monitoring. **Conclusions:** COR388 is a promising drug for the treatment of AD with a novel mechanism of action. COR388 is readily bioavailable after oral administration with a favorable PK profile. COR388 was safe and well tolerated by older subjects and patients with AD when given at doses

ranging from 25 to 100 mg for up to 28 days. Based on this positive safety and PK data, Cortexyme is planning to initiate a large phase 2 study of COR388 in mild to moderate AD in 2019.

LBP17: SOUVENOID IN COGNITIVE DETERIORATION. OUR EXPERIENCE AFTER 5 YEARS OF TREATMENT AND FOLLOW-UP. Miquel Aguilar, Paquita Soler. Nurse (*Aptima Mutua Terrassa, Catalunya, Spain*)

Background: Alzheimer's disease and relative disorders are associated with early synaptic loss. Memory improves administering early specific multinutrient products such as Fortasyn Connect (Souvenaid); It is thought that the mechanism is the improvement in synapse formation and/or in brain network connectivity. There is little literature, which refers to its efficacy in psychological and behavior symptoms (PBS). **Objectives:** We present our experience in the follow-up of 232 patients in a period of 5 years. Analyze its efficacy on clinical manifestations and its repercussions on activities of daily living (ADL). **Methods:** This study is an open-label treatment with Souvenaid, observational, prospective, with a protocol evaluation of cognition (MMSE), memory (MMSE, FCRST), PBS (NPI) and ADL (Blessed) at baseline and at 6, 12, 24 and 36 months. We evaluated 232 patients (87 males and 145 females), divided in two groups: Mild Cognitive Impairment (MCI-group) (167) (72%) and mild dementia (Dementia-group) (65) (28%). We analyzed the two groups, and different sub-groups according to genre (males or females), etiology, schooling levels (low(0-5 years), middle(6-10 years) or high(11-20 years); treatment with or without ACHIs and with or without psychoactive drugs. **Results:** 164 patients were married (70,7%). 84 were living in company (79,3%). Years of schooling were (7,47±4,26). Disease onset age: (70,25±8,37). Age at entry in study: (74,77±7,87). Interval between onset and treatment start (4,57±3,31 years). The etiology of the deterioration was Alzheimer disease (AD) 186 (80,2%), Parkinson-Dementia 3 (1,3%), Lobar Frontal Temporal Dementia (LFTD) 13 (5,6%), Vascular Dementia (VD) 9 (3,9%), other degenerative dementias 1 (0,4%) and secondary dementias 20 (8,6%). Adverse effects: 8 (3,4%), hyperglycemia (2), diarrhea (3), nausea (2) and rhinorrhea (1). The patients of MCI-group were younger ($p<0,0001$) and their time of Souvenaid prescription was shorter than Dementia-group ($p=0,023$). Basal total scores of scales (MMSE, FCRST, Blessed-ADL, NPI) were worse in Dementia-group. After 6 months of treatment with Souvenaid, in the MCI-group the MMSE-total score between basal and 6 months was (25,66±3,00 vs 26,09±2,9; NS); recall (1,22±0,99 vs 1,45±1,10; $p<0,05$), FCRST-total free memory (16,40 ±8,36 vs 17,70±9,39; NS), Blessed-ADL scale (1,22±1,32 vs 1,10±1,06; NS). The efficacy in PBS evaluated with NPI-total score was (14,47±12,74 vs 7,68±7,93; $p<0,0001$), it showed improvement of depression ($p<0,0001$), anxiety ($p<0,001$), apathy ($p=0,03$) and motor disturbances ($p=0,025$). Analysis case to case demonstrated that the percentage of patients who were better than at basal was; for cognition (40,0%), MMSE-recall (38,0%), FCRST-free memory (48%), ADL (38,9%), and in PBS (56,5%). In Dementia-group: All scales showed little changes, without statistical significance, except in anxiety and apathy. Analysis case to case showed that the percentage of patients who were better was; for cognition (40,8%), MMSE-recall (26,5%), FCRST free memory (15,0%), functionality (26,5%), and PBS (46,9%). The MCI-group improved more than the dementia-group. PBS benefits were better in the subgroups of patients with a

higher basal NPI-total score (>20) than the subgroup with a lower score (0-20). At 12 months, MCI-group maintained stable in cognition, memory and ADL, and better in PBS ($p=0,002$); Dementia-group worsened in global cognition and ADL; maintained stable in memory and PBS. At 24 months, MCI-group (43p) was stable in cognition and BPS and worsened in ADL, the percentage of better condition was; for cognition (29,1%), memory (20,8%), ADL (20,4%) and BPS (45,3%). At 36 months, the MCI-group (25p) maintained better in cognition (35,7%), memory (46,4%), ADL (14,3%) and PBS (44,4%). If divided into the function of genre, differences in demographic data were found. Females were older than males ($p=0,006$), with lower schooling ($p<0,001$), a higher proportion of widows and more lived alone. Males had higher scores than females in MMSE-total score, calculation, and capacity to write sentences, and copy a design. Both subgroups showed similar basal scores in Blessed- ADL and NPI-total score. After 6 months, both genre subgroups improved in calculation and in PBS. Females showed more improvement than males in depression, anxiety, apathy, irritability and motor disturbances. Females increased in functionality ($p<0,0001$). Analysis case to case showed few differences in global cognition and in memory between sub-groups. In the follow-up at 12, 24, 36 months, females showed more efficacy than males in ADL and PBS. Analysis of other subgroups according to schooling levels; treatment with or without ACHIs; treatment with or without psychoactive drugs; and etiology did not show significant differences between subgroups. **Conclusions:** Souvenaid is beneficial as a complementary treatment in MCI and mild dementia, the best results are in patients who start the treatment early. After 6 months, benefits in memory and PBS (depression, anxiety, apathy and movement disorders) can be demonstrated; global cognition and functionality are stable. If this treatment is continued for longer periods, patients remain stable or worsen more slowly. The improvement in PBS persists and is better in the patients with higher basal NPI-total score. Many patients were better in the follow-up. Females improve more than males in ADL and PBS.

LBP18: IS RAGE THE MISSING LINK BETWEEN DIABETES AND DEMENTIA? RESULTS FROM A SUBGROUP ANALYSIS OF THE STEADFAST TRIAL. Carmen Valcarce¹, Imogene Dunn¹, Tom Soeder², Aaron Burstein¹ ((1) *vTv Therapeutics LLC, High Point, NC, USA*; (2) *CATO Research Ltd., Durham, NC, USA*)

Background: The association between diabetes and dementia is well documented, and numerous studies have suggested a link between type 2 diabetes (T2D) and Alzheimer's disease (AD). Recently, a linear correlation between circulating hemoglobin A1c (HbA1c) levels and cognitive decline has been demonstrated in the English Longitudinal Study of Ageing. The Receptor for Advanced Glycation End-products (RAGE) is a multiligand receptor of the immunoglobulin superfamily. The multiligand nature of RAGE is highlighted by its ability to bind diverse ligands such as advanced glycation end-products (AGEs), linked to diabetic complications and β -amyloid fibrils, a hallmark of AD. The pathogenic role of RAGE in chronic inflammation is well-documented. RAGE is sharply upregulated in numerous cell types under pathological conditions, and RAGE-ligands upregulate the receptor's expression establishing a vicious cycle that perpetuates inflammation and prevents tissue repair. Neuroinflammation has emerged as a key

component of AD pathology, and participation of RAGE signaling in neurodegenerative diseases via direct effects on neurons and indirect effects through microglia and astrocyte activation is well established. Moreover, increased expression of RAGE has been shown postmortem in the brain of AD patients. Similarly, a direct correlation between AGEs and the development and progression of diabetic vascular disease and complications has been reported, and the presence of low-level inflammation in diabetic complications is supported by numerous experimental evidence in the macro- and microvasculature. The role of inflammation and RAGE expression/signaling associated with AD and T2D raises the question of whether RAGE could be a common denominator between AD and T2D and whether treatment with azeliragon, an oral RAGE-inhibitor, could have a distinct effect in patients presenting both T2D and AD. This hypothesis was born from the observation in the phase 2b study of azeliragon: that AD patients with high fasting plasma glucose or prediabetes (diabetic subjects were excluded from this study) responded better to treatment with azeliragon. **Objectives:** To determine if a differential response to azeliragon was observed in patients presenting both T2D and AD participating in the STEADFAST trial. **Methods:** The STEADFAST study was a randomized, double-blind, placebo-controlled trial in approximately 800 patients with probable mild AD, MMSE 21-26, CDR global 0.5-1, receiving stable standard of care therapy (acetylcholinesterase inhibitor and/or memantine; SoC) evaluating the efficacy and safety of 18 months of treatment with azeliragon 5 mg/day relative to placebo. The clinical trial design included two separate studies (A-Study and B-Study) operationally conducted under a single protocol. Each study was randomized separately and independently powered to evaluate efficacy with respect to co-primary endpoints of ADAS-cog and CDR-sb. Entry criteria excluded patients with HbA1c >7.7%. For this subgroup analysis, T2D was defined by HbA1c of 6.5% or more at baseline. **Results:** A total of 56 patients with T2D and a clinical diagnosis of AD were identified across both the A-study and B-Study (n=23 placebo and n=33 azeliragon). Baseline characteristics were reasonably balanced between treatment groups for demography, background traits, and baseline characteristics, including characteristics of specific interest: sex, age, APOE status, and HbA1c. Safety analysis revealed no trends or treatment-emergent adverse events (TEAEs) of concern among subjects treated with azeliragon relative to placebo in this subgroup. Placebo-subtracted incidences in TEAEs tended to be neutral. The most commonly reported TEAEs were in the infections and infestations system organ class, reported by approximately 30% of patients in both treatment groups. The TEAE profile for azeliragon for this subgroup did not differ from that of the whole study. Efficacy analysis revealed that patients with T2D and AD treated with azeliragon did not show statistically significant cognitive decline (measured as changes in ADAS-cog 11) when compared to baseline at any time during the study. In contrast, patients treated with placebo did show a statistically significant decline beginning at month 6. Treatment differences between azeliragon-treated patients and placebo were significant (nominal p<0.05), despite the small number of subjects in this analysis. Results were robust against the choice of statistical model, parametric or nonparametric analysis, or methodology for handling missing data. **Conclusions:** The results of this analysis indicate a potential benefit of treatment with azeliragon for patients with T2D and AD or AD-related dementias. A

limitation of this analysis is the small number of subjects with both conditions participating in the STEADFAST trial. Further studies are needed to confirm these promising results.

LBP19: ADUCANUMAB 48-MONTH ANALYSES FROM PRIME, A PHASE 1B STUDY IN PATIENTS WITH EARLY ALZHEIMER'S DISEASE. Philipp von Rosenstiel¹, Samantha Budd Haerberlein¹, Carmen Castrillo-Viguera¹, Tianle Chen¹, John O'Gorman¹, Raj Rajagovindan¹, Dakshaben Patel², Guanfang Wang³, Spyros Chalkias¹, LeAnne Skordos¹, Claudia Prada¹, Christoph Hock⁴, Roger M Nitsch⁴, Alfred Sandrock¹ ((1) Biogen, Cambridge, MA, USA; (2) Biogen, Maidenhead, UK; (3) Cytel, Cambridge, MA, USA; (4) Neurimmune, Schlieren-Zurich, and University of Zurich, Switzerland)

Background: Aducanumab (BIIB037), a human anti-amyloid beta (A β) monoclonal antibody, is being investigated as a disease-modifying treatment for early Alzheimer's disease (AD). PRIME is an ongoing Phase 1b study evaluating the safety, tolerability, pharmacokinetics, and pharmacodynamics of aducanumab in patients with prodromal AD and mild AD dementia¹. **Objectives:** Here, we report 48-month amyloid positron emission tomography (PET) and clinical endpoint data for fixed-dose cohorts, including 12 months from the PRIME placebo-controlled period and 36 months from the PRIME long term extension (LTE). Cumulative safety data for both fixed-dose and titration cohorts, as of the most recent interim analysis, is also reported. **Methods:** Patients in this randomized, double-blind, placebo-controlled study (PRIME; NCT01677572) were aged 50–90 years, had a positive florbetapir PET scan, and met clinical criteria for prodromal or mild AD dementia. During the double-blind, placebo controlled period, patients received aducanumab or placebo q4w for 52 weeks. In a staggered, parallel-group design, patients were randomly assigned (3:1) to fixed doses of aducanumab (1, 3, 6 or 10 mg/kg) stratified by ApoE ϵ 4 status (carrier/non-carrier) or placebo. The study also included a dose titration cohort (not reported here; 48-month data for the titration cohort are not yet available). At Week 56, eligible patients could enroll into the LTE, where all patients were assigned to receive aducanumab. LTE dose assignments were as follows: patients initially randomized to receive placebo were assigned treatment in the LTE to either aducanumab 3 mg/kg, a titration regimen of aducanumab 3 to 6 mg/kg (2 doses of 3 mg/kg followed by subsequent doses of 6 mg/kg), or a titration regimen of aducanumab up to 10 mg/kg (1 mg/kg [2 doses]; 3 mg/kg [4 doses]; 6 mg/kg [5 doses]; 10 mg/kg thereafter). Patients initially randomized to receive aducanumab 1 mg/kg were assigned to receive aducanumab 3 mg/kg in the LTE. Patients randomized to the aducanumab titration regimen or to fixed doses of aducanumab (3, 6, or 10 mg/kg) in the placebo-controlled period continued at their original dose assignment in the LTE. The primary endpoint for the PRIME LTE was safety. Other endpoints (amyloid PET, Clinical Dementia Rating–Sum of Boxes [CDR–SB] and Mini-Mental State Examination [MMSE]) were exploratory. A mixed model for repeated measures was used for analysis of change from baseline in amyloid PET, CDR–SB and MMSE. **Results:** Of 165 patients randomized and dosed in PRIME within the fixed-dose cohorts, 117 were dosed in the LTE and 59 completed treatment at Month 48. In patients treated up to 48 months, amyloid plaque as measured by PET, continued to decrease in a dose- and time-dependent manner, with mean amyloid plaque levels in the 10 mg/kg fixed-dose treatment

group reaching and remaining at an SUVR level below 1.1, which is considered the quantitative cut-point suggested to discriminate between a positive and negative scan.² CDR-SB and MMSE data suggest a clinical benefit in patients continuing aducanumab over 48 months. Since the start of the PRIME study, 185 patients from fixed-dose and titration cohorts have been dosed with aducanumab. 46 of these patients experienced ARIA-E. Of those patients, 61% were asymptomatic and 39% were symptomatic. The majority of symptomatic case of ARIA-E exhibited symptoms which were mild to moderate in severity. 8 patients experienced more than one episode of ARIA-E. These recurrent ARIA events were generally consistent with other ARIA reported from the PRIME study to date; they were typically asymptomatic, and most patients continued in the study. **Conclusions:** In patients from fixed-dose cohorts who completed the third year of the LTE, amyloid plaque levels continued to decrease in a dose- and time-dependent manner, with the 10 mg/kg cohort remaining below a mean SUVR threshold of 1.1. Analyses of exploratory clinical endpoints CDR-SB and MMSE were generally consistent with those reported in previous interim analyses and suggest a continued benefit on the rate of clinical decline over 48 months. The safety profile of aducanumab remains unchanged. These data support further investigation of aducanumab in patients with early AD in the ENGAGE and EMERGE Phase 3 trials.¹ Sevigny J et al. *Nature*. 2016;537:50-56; 2. Joshi AD, et al. *J Nucl Med*. 2015;56:1736-1741.

LBP20: BASELINE DATA FROM THE API AUTOSOMAL DOMINANT ALZHEIMER'S DISEASE COLOMBIA TRIAL. Pierre N. Tariot¹, Francisco Lopera², Kaycee M. Sink³, Nan Hu³, Heather Guthrie³, Jillian Smith⁴, William Cho³, Jessica B. Langbaum¹, Ronald G. Thomas⁵, Kewei Chen¹, Yi Su¹, Dhruvan Goradia¹, Pradeep Thiyyagura¹, Paul S VanGilder¹, Ji Luo¹, Valentina Ghisays¹, Wendy Lee¹, Michael H. Malek-Ahmadi¹, Hillary D. Protas¹, Yinghua Chen¹, Carole Ho³, Shehnaaz Suliman³, Sergio Alvarez⁵, Yakeel T. Quiroz⁶, Robert Paul⁷, Silvia Rios Romanets², Eric M. Reiman¹, and the API ADAD Colombia Trial Group. ((1) Banner Alzheimer's Institute, Phoenix, AZ, USA; (2) Grupo de Neurociencias de Antioquia of Universidad de Antioquia, Medellin, CO, (3) Genentech Inc., South San Francisco, CA, USA; (4) Roche Products Ltd, Welwyn Garden City, UK; (5) University of California, San Diego, CA, USA; (6) Hospital Pablo Tobon Uribe, Medellin, CO; (7) Harvard Medical School and Massachusetts General Hospital, Boston MA, USA)

Background: The Alzheimer's Prevention Initiative (API) was established to accelerate Alzheimer's disease (AD) prevention research, forge public-private partnerships, conduct prevention trials with maximal scientific benefit, clarify biomarker utilities, share data and biological samples after trials are completed, and share baseline data before our trials are completed. We present baseline data from the API Autosomal Dominant AD (ADAD) Colombia Trial in Presenilin 1 (PSEN1) E280A mutation carriers and non-carriers. **Methods:** The API ADAD Colombia Trial is a 5-8 year, randomized, placebo-controlled prevention trial (using a common-close design) of the investigational amyloid- β ($A\beta$) antibody therapy crenezumab in 252 unimpaired 30-60-year-old kindred members, including mutation carriers who were randomized to active treatment or placebo and non-carriers who receive placebo only, to mask mutation status. Among carriers, we will compare rates of change on drug vs. placebo in clinical and biomarker outcomes, addressing whether

treatment shows a clinical-biomarker pattern indicative of slowed progression of illness. The primary outcome is change in the API ADAD Composite Cognitive Test Score from baseline to week 260. Secondary outcomes include time to progression to mild cognitive impairment/dementia due to AD; changes in dementia severity, memory, and overall neurocognitive functioning; and changes in amyloid-PET, FDG-PET, MRI volumes, and cerebral spinal fluid levels of β -amyloid, tau, and p-tau. Safety and tolerability are assessed. **Results:** We will summarize baseline participant demographics, selected clinical and cognitive data, and available imaging data. The baseline data are partially censored to preserve participant anonymity. Where possible, we will also add data from an earlier cross-sectional clinical and biomarker study completed in this population (Fleisher et al, 2015) in order to include data from persons across a broader age range as well as from those with symptoms of AD, allowing us to provide a more complete picture of the pattern of changes seen at different ages in ADAD. **Conclusions:** The API ADAD Colombia Trial baseline data available thus far provide further insights into age-associated changes in clinical and biomarker characteristics. Investigators can apply for use of baseline data from the trial as soon as these are uploaded to API's data sharing portal; until then, they may send inquiries to APIdata@bannerhealth.com.

Theme: Clinical trials: Imaging

LBP21: PREDICTION OF TREATMENT RESPONSE TO DONEPEZIL USING AUTOMATED HIPPOCAMPAL SUBFIELDS VOLUMES SEGMENTATION IN PATIENTS WITH MILD ALZHEIMER'S DISEASE. Sheng-Min Wang¹, Yoo Hyun Um², Chang-Uk Lee³, Hyun Kook Lim³ ((1) Department of Psychiatry, Yeouido St. Mary's Hospital, College of Medicine, The Catholic University of Korea, Seoul - Republic of Korea; (2) St. Vincent's Hospital, College of Medicine, The Catholic University of Korea, Suwon - Republic of Korea; (3) Department of Psychiatry, Seoul St. Mary's Hospital, College of Medicine, The Catholic University of Korea, Seoul - Republic of Korea)

Background: Previous studies reported some relationships between donepezil treatment and hippocampus in Alzheimer's disease (AD). However, due to methodological limitations, their close relationships remain unclear. The aim of this study is to predict treatment response to donepezil by utilizing the automated segmentation of hippocampal subfields volumes (ASHS) in AD. **Methods:** Sixty four AD patients were prescribed with donepezil and were followed up for 24 weeks. Cognitive function was measured to assess whether there was a response from the donepezil treatment. ASHS was implemented on non-responder (NR) and responder (TR) groups, and receiver operator characteristic (ROC) analysis was conducted to evaluate the sensitivity, specificity, and accuracy of hippocampal subfields in predicting response to donepezil. **Results:** The left total hippocampus and the CA1 area of the NR were significantly smaller than those of the TR group (table 1). The ROC curve analysis showed the left CA1 volumes showed highest area under curve (AUC) of 0.85 with a sensitivity of 88.0%, a specificity of 74.0% in predicting treatment response to donepezil treatment (figure 1). **Conclusions:** We expect that hippocampal subfields volume measurements that predict treatment responses to current AD drugs will enable more evidence-based, individualized prescription of medications that will lead to more favorable treatment outcomes. References: 1.

National Institute for Clinical Excellence (NICE) Technology appraisal guidance. 2011. Donepezil, galantamine, rivastigmine and memantine for the treatment of Alzheimer's disease; p. 217. 2. Burns A, Yeates A, Akintade L, del Valle M, Zhang RY, Schwam EM, et al. Defining treatment response to donepezil in Alzheimer's disease: responder analysis of patient-level data from randomized, placebo-controlled studies. *Drugs Aging*. 2008;25:707–714.

Table 1

Demographic and clinical characteristics of study participants

	TR (N=38)	NR (N=26)	p-value
Age (years±SD)	69.8±4.1	71.1±6.5	NS
Education (years±SD)	9.5±4.3	9.6±3.7	NS
Sex (M:F)	14:24	10:16	NS
CDR	0.8±0.3	0.8±0.3	NS
CDR-SB	4.8±1.5	4.5±2.2	NS
Total ICV (mm ³ ±SD)	136,391±143,029.5	1,356,751±116,988.8	NS
Left normalized volume (mm ³ ±SD)			
Total hippocampus	2,131.9±239.3	1,901.9±229.9	<0.0001
CA1	1,112.2±170.6	937.1±146.3	<0.0001
CA2	12.0±2.1	11.6±3.2	NS
CA3	47.5±4.4	47.1±4.4	NS
DG	625.6±94.0	572.4±111.2	NS
SUB	334.4±43.1	333.6±25.8	NS
Right normalized volume (mm ³ ±SD)			
Total hippocampus	1,965.4±336.7	1,893.7±218.6	NS
CA1	1,017.2±207.9	980.0±184.9	NS
CA2	12.2±4.3	13.2±4.3	NS
CA3	39.9±9.6	37.5±9.3	NS
DG	600.4±113.6	551.9±114.5	NS
SUB	295.5±44.0	311.0±29.6	NS

TR: treatment responder, NR: treatment non-responder, SD: standard deviation, CDR: Clinical Dementia Rating, CDR-SB: CDR sum-of-box, MMSE: Mini Mental Status Examination, ICV: intracranial volume

Figure 1

(A) Segmentation scheme used for hippocampal subfields segmentation used in this study; B) The predictive performances of baseline hippocampal subfields volume measurements in 24 weeks donepezil treatment in the patients with AD; C) Group differences of baseline hippocampal subfields volumes between the TR and the NR groups. AD: Alzheimer's disease, TR: treatment response, NR: treatment non-response, L-CA1: left cornu ammonis region 1 region, L-TOTALHIPPO: left total hippocampus, L: left, R: right, TOT: total hippocampus, CA1: Cornu ammonis region 1, CA2: Cornu ammonis region 2, CA3: Cornu ammonis region 3, DG: dentate gyrus, SUB: subiculum.

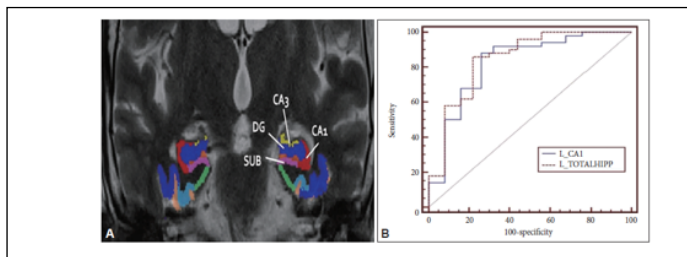

LBP22: ROLE OF CONFLUENT WHITE MATTER LESIONS IN THE PROGRESSION TO ALZHEIMER'S DEMENTIA IN AN ASIAN CLINIC COHORT. Nagaendran Kandiah (*National Neuroscience Institute, Singapore*)

Background: Alongside AD pathology, cerebrovascular disease (CVD) also contributes to the differential progression rates from prodromal dementia to dementia. As CVD is prevalent, identification of specific type of CVD lesions that influence progression to dementia are needed. **Aims:** To evaluate the role of CVD in the progression from mild cognitive

impairment (MCI) to dementia and to investigate if confluent WMH lesions poses a significantly higher risk for progression to dementia. **Methods:** Patients with MCI as per the NIA-AA criteria from a clinic cohort having a baseline MRI and a minimum follow-up period of 18 months were evaluated. WMH was quantified using semiquantitative Fazekas scoring at baseline for all subjects and additionally at end of study period for a subgroup. Influence of baseline total WMH, baseline confluent WMH and progression of WMH on rates of progression from MCI to dementia were analysed. **Results:** 200 patients with a mean age of 67.9 (SD 8.7) years were evaluated. Progression to dementia was significantly higher among MCI subjects with confluent WMH compared to those with non-confluent WMH lesions (55.7% vs 32.3%; $p < 0.001$). The Odds of a patient with confluent WMH progressing to dementia was 2.66 (CI: 1.29-5.47; $p = 0.008$). The annual decline in MMSE was significantly higher in those with confluent WMH lesions (-1.60 vs -1.20; $p = 0.010$). **Conclusion:** WMH in MCI is a risk factor for progression to dementia. Confluent WMH lesions are associated with higher rates of progression to dementia.

LBP23: APOE4/4 EARLY TO MILD AD SUBJECTS SHOW HIGH RATES OF HIPPOCAMPAL ATROPHY AND COGNITIVE DECLINE IN ADNI-1 AND TRAMIPROSATE DATASETS. Susan Abushakra¹, Luc Bracoud², Joël Schaerer², Aidan Power¹, John Hey¹, David Scott³, Joyce Suh³, Martin Tolar¹ & the Alzheimer Disease Neuroimaging Initiative (ADNI) ((1) *Alzheon Inc., Framingham, MA, USA*; (2) *Bioclinica, Lyon France* (3) *Bioclinica, Newark CA, USA*)

Background: The apolipoprotein ε4 allele (APOE4) is a major genetic risk factor for Alzheimer's disease (AD), with APOE4 carriers (homozygotes and heterozygotes) comprising ~65% of AD patients. APOE4 increases beta amyloid (Aβ) monomer production, diminishes clearance and increases their aggregation into soluble neurotoxic oligomers. Homozygotes have shown high rates of fibrillar amyloid pathology, high Aβ oligomer burden, and early cognitive decline. Homozygotes are thus an optimal target population for drugs that inhibit Aβ oligomer formation, such as tramiprosate or its pro-drug ALZ-801 (Abushakra 2017, Kocis 2017, Hey 2017). **Objectives:** To optimize imaging biomarker selection for a planned ALZ-801 trial in Early to Mild AD, we analyzed datasets from ADNI-1 and the subset of a tramiprosate Phase 3 study that underwent serial volumetric MRI. We evaluated atrophy rates of hippocampus and other MRI measures, and their correlations to clinical decline in APOE4/4 and APOE3/3 subjects. **Methods:** ADNI-1 study enrolled 722 subjects, comprising 255 Cognitively Normal (CN), 301 Late Mild Cognitive Impairment (LMCI) and 166 Mild Alzheimer's Disease (AD) individuals. LMCI group had 228 APOE3/3 non-carriers and 73 APOE4/4 carriers, while the AD group had 101 APOE3/3 and 65 APOE4/4 subjects. We analyzed data from the subgroup with MRIs at baseline, 12 and 24 months (<http://adni.loni.ucla.edu>), that included: LMCI (93 APOE3/3, 29 APOE4/4) and AD (29 APOE3/3, 21 APOE4/4). Clinical scores (MMSE, ADAScog13, CDR-SB) were collected at Baseline and Months 3, 6, 9, 12, 18 and 24. The 3D T1-weighted MRI collection consisted of MP RAGE (Siemens), 3D TFE (Philips) and 3D Fast SPGR (General Electric) pulse sequences, with 1.25×1.25×1.2 mm³ voxel resolution in sagittal orientation. The tramiprosate dataset, the Mild subgroup of APOE4/4 patients (MMSE 20-26) with MRI data at screening and Week 78, included 15 APOE4/4 subjects in placebo

arm. The 3DT1 protocol consisted of MP RAGE (Siemens), 3D TFE (Philips) and 3D Fast SPGR (General Electric) pulse sequences, with $1.0 \times 1.0 \times 1.6$ mm³ voxel resolution in coronal orientation. Data were processed centrally with fully-automated methods: FreeSurfer v5.3 for brain segmentation at Baseline. Volumes of whole brain (WBV), lateral ventricles (LVV) and hippocampus (HCV= L+R) were derived. Volume changes at follow-up timepoints were assessed using Boundary Shift Integral. Cortical thickness was measured using FreeSurfer, Mayo AD signature ROI (Jack 2017) was calculated at Baseline, changes were analyzed by a Jacobian-based method. Baseline volumetric measures were adjusted for age, years of education, and head size. Clinical score changes were estimated by fitting a linear model for each subject. Correlations between baseline MRI measures, clinical decline, and volumetric changes at M24 were analyzed by Pearson's correlations. Comparative analyses were focused on APOE3/3 versus APOE4/4 subjects in LMCI and AD groups. **Results:** Demographics and baseline scores in the LMCI and AD groups were similar except for APOE4/4 subjects being significantly younger than APOE3/3 with a smaller HCV ($p < 0.001$). In LMCI but not AD group, APOE4/4 subjects also had higher ADAScog than APOE3/3 ($p = 0.016$). Across the 4 subgroups at baseline, the smallest HCV was in APOE4/4 AD subjects, followed by APOE4/4 LMCI, APOE3/3 AD, then APOE3/3 LMCI. Hippocampal volume changes: HCV showed significantly greater % decline at 24 months in APOE4/4 AD subjects than the APOE3/3, and in APOE4/4 LMCI than APOE3/3. The order of decline was greatest in APOE4/4 AD, followed by APOE3/3 AD subjects, then APOE4/4 LMCI and smallest in APOE3/3 LMCI. In APOE4/4 subjects, annualized decline rate at 24 months was ~8% in AD, ~5.5% in LMCI, while tramiprosate APOE4/4 Mild AD subjects showed ~6% decline at Week 78. In ADNI-1, cortical thickness in APOE4/4 and APOE3/3 groups showed a similar pattern with largest decline in APOE4/4 AD subjects. Correlation of baseline volumetrics to clinical changes: In APOE4/4 LMCI, baseline cortical thickness (Mayo index) correlations to MMSE worsening was moderately strong and significant ($r = 0.62$). Other correlations were weaker or not significant. Correlation of volumetric changes to clinical changes: In the APOE4/4 group, significant correlations of HCV, WBV, and cortical thickness changes to ADAScog and MMSE worsening over 24 months were observed for LMCI group, but were not significant in the AD group. In the LMCI group, r -values for ADAScog were 0.54-0.64, and for MMSE were 0.38-0.62 (all $p < 0.05$). **Conclusions:** APOE4/4 subjects with Mild AD show high rates of hippocampus atrophy over 12 and 24 months. APOE4/4 Mild AD subjects from the tramiprosate Phase 3 study show a similar but slightly lower HCV decline than the corresponding ADNI dataset. APOE4/4 homozygotes at the LMCI stage (Early AD) also show high rates of HCV atrophy which correlate well with worsening of cognitive scores (ADAScog, MMSE). Confirmation of this hippocampal atrophy-cognitive decline relationship in larger studies, may allow use of HCV as a surrogate outcome in Early AD trials. These data also support the important role of HCV as an imaging biomarker outcome in future ALZ-801 trials in Early to Mild AD.

LBP24: PRELIMINARY CHARACTERIZATION OF 18F-RO948 PET IMAGING AMONG COGNITIVELY UNIMPAIRED AND PATIENTS WITH MCI OR DEMENTIA IN THE BIOFINDER2 STUDY. Gregory Klein¹, Ruben Smith², Sebastian Palmqvist², Niklas Mattsson², Danielle van Westen², Olof Strandberg², Jonas Jögi², Tomas Ohlsson², Edilio Borroni¹, Preciosa Coloma¹, Erik Stomrud², Oskar Hansson² ((1) Roche Pharma Research and Early Development, Basel, Switzerland; (2) Clinical Memory Research Unit, Lund University, Sweden)

Background: The Swedish BioFINDER2 (Biomarkers For Identifying NeuroDegenerative Disorders Early and Reliably) Study is a prospective study driven by researchers at Skane University Hospital that focuses on identifying key mechanisms and improved diagnosis of Alzheimer's Disease (AD) and other neurodegenerative disorders. The study started in May 2017 and aims to recruit more than 1500 subjects across the AD spectrum, including cognitively unimpaired, with subjective cognitive decline and mild cognitive impairment as well as other types of dementia. Here we report tau PET imaging characteristics for the first 223 patients scanned with 18F-RO948. **Objectives:** Describe the distribution of tau pathology using 18F-RO948 PET and its correlation with demographic and clinical characteristics of cognitively normal individuals and patients with MCI, clinically diagnosed AD and other dementias recruited to date in the BioFINDER2 study. **Methods:** All study participants are scanned at baseline with 18F-RO948 tau PET on one of three identically configured GE Discovery MI PET scanners in the Lund, Sweden area. Each week, approximately 10-14 patients are scanned from a single batch production of 18F-RO948. The target activity of a single administration is 370 MBq. PET scans are obtained during 20 minutes, 70-90 min post injection. Patients are also scanned with an extensive MRI protocol using a MAGNETOM Prisma 3T scanner (Siemens), including a high-resolution MPRAGE sequence used in PET processing. FreeSurfer v5.3 is used to obtain SUVR images using an inferior cerebellar grey reference region. A regional analysis of the PET data is carried out using a Braak staging model as described by Scholl, which defines ROIs approximating the anatomical definitions of transentorhinal (Braak stage I/II), limbic (III/IV), and isocortical (V/VI) Braak stages [1]. Other potential reference regions including the brainstem and white matter were also investigated. All patients with cognitive symptoms undergo structured cognitive, neurological and psychiatric evaluations, as well as assessments of ADLs, subjective cognitive symptoms, behavioral symptoms, sleep, comorbidities, concomitant medications, as well as motor function and visuospatial navigation. CSF is collected and analysed directly for A β 42, A β 40, Ttau, Ptau and a number of other exploratory markers using two fully automated platforms (Roche Elecsys and Fujirebio Lumipulse). Plasma and whole blood samples are also collected for future analysis. **Results:** As of July, 2018, 223 patients have undergone 18F-RO948 tau PET imaging. The participants have a mean age of 68.6 years (SD 12) and 52% are males. The distribution of clinical diagnoses is as follows: cognitively unimpaired younger controls (YC) $n = 30$; cognitively unimpaired older controls (OC) $n = 21$; subjective cognitive decline (SCD) or mild cognitive impairment (MCI), $n = 84$; AD, $n = 50$; other dementias, $n = 30$; unknown or not specified. Other dementias include: behavioural variant frontotemporal dementia (bvFTD, $n = 6$); Dementia with Lewy Body (DLB, $n = 13$); Parkinson's Disease Dementia (PDD, $n = 2$); vascular dementia (VaD, $n = 4$); semantic dementia (SD, $n = 2$); and

progressive supranuclear palsy (PSP, n=3). Four of the subjects with unknown clinical diagnosis were excluded from the study, including 2 who died and 1 who withdrew participation. More than half (53%) of the participants are ApoE ϵ 4 non-carriers, 41% are ApoE ϵ 4 heterozygotes, 6% are ApoE ϵ 4 homozygotes, and one subject has unknown ApoE genotype. The median score for the baseline Mini Mental Status Examination (MMSE) is 27 (range 10-30). Focusing on 18F-RO-948 data from the AD, SCD/MCI, OC and YC groups, significant separation (t-test p-value < 0.01) was seen between AD and the OC/YC groups for all three Braak regions, and for the SCD/MCI : YC groups in Braak region 1/2. Effect size using a brainstem reference region was slightly larger than for SUVR with inferior cerebellar grey reference. Tau burden was inversely associated with MMSE, with a Pearson's correlation coefficient of -0.69 in Braak region 3/4. Dynamic range of SUVR voxels reference to inferior cerebellum typically ranged from 0 to 4.0 for patient with tau pathology. Little off-target binding was seen in the striatum and choroid plexus, occasionally in the meningeal regions and frequently in the substantia nigra and retina. **Conclusions:** The Biofinder2 observational study is rapidly enrolling subjects and characterizing them with a wide range of clinical and biomarker assessments. Initial results show the second-generation tau PET tracer, 18F-RO948 has a high dynamic range with little off-target binding and ability to distinguish significant tau burden differences between patient clinical classifications.

Theme: Clinical trials: Biomarkers including plasma

LBP25: DISCOVERY OF AN ENDOGENOUS METABOLITE OF TRAMIPROSATE AND ITS PRODRUG ALZ-801 THAT INHIBITS BETA AMYLOID OLIGOMER FORMATION IN HUMAN BRAIN. John A. Hey¹, Petr Kocis¹, Jakub Hort^{2,3}, Susan Abushakra¹, Aidan Power¹, Martin Vyhnanek^{2,3}, Jeremy Y. Yu¹, Martin Tolar¹ ((1) *Alzheon, Inc., Framingham, MA, USA*; (2) *International Clinical Research Centre, St. Anne's University Hospital Brno, Brno, Czech Republic*; (3) *Cognitive Center, Department of Neurology, Charles University, 2nd Faculty of Medicine and Motol University Hospital, Czech Republic*)

Background: ALZ-801 is an oral, small molecule inhibitor of beta amyloid (A β) oligomer formation in clinical development for Alzheimer's disease (AD). ALZ-801 is a prodrug of tramiprosate with improved pharmacokinetic properties and gastrointestinal tolerability. During clinical studies, we discovered that the primary metabolite of tramiprosate and its prodrug ALZ-801, 3-sulfopropionic acid (3-SPA), is an endogenous molecule in the human brain and is found in cerebrospinal fluid (CSF) of patients with AD and other neurodegenerative diseases (Hey et al, 2018; <https://doi.org/10.1007/s40263-018-0554-0>). **Objectives:** The objectives of the study were: 1) identify and confirm the presence of 3-SPA in human CSF samples from elderly, drug-naïve, patients with memory deficits, 2) quantify the levels of 3-SPA in the CSF of patients with AD from the tramiprosate Phase 3 trial, 3) evaluate the in vitro anti-A β 42 oligomer activity of 3-SPA, and 4) characterize the pharmacokinetic (PK) and brain penetration properties of 3-SPA. **Methods:** Lumbar CSF samples were analyzed from drug naïve patients with cognitive deficits (MMSE range: 15-30), patients with AD treated with 150 mg BID of tramiprosate in the Phase 3 trial at Week 78, and normal drug naïve subjects. We used LC-MS/MS for structural molecular

identity confirmation of endogenous 3-SPA with a 3-SPA reference standard, and ion mobility-mass spectrometry with molecular dynamics to characterize interactions of 3-SPA with A β 42 monomers, and the resultant conformational alterations. Rat studies using 30 mg/kg oral and 10 mg/kg intravenous doses were conducted to characterize the PK properties and brain penetration of 3-SPA. **Results:** We confirmed the presence of 3-SPA in the CSF of drug naïve patients with cognitive deficits (mean concentration 11.8 ± 4.3 nM, n= 64, mean age 68.6 yr) and normal, drug naïve adults (mean concentration 15.0 ± 8.2 nM, mean age 49.9 yr). The mean concentration of 3-SPA in AD patients treated with tramiprosate was 135 ± 51 nM. In vitro investigations in to the activity of 3-SPA revealed a multi-ligand interaction with monomeric A β 42 that inhibits the aggregation of A β 42 into small soluble oligomers. Comparisons of the molecular interactions of tramiprosate and 3-SPA with Ab42 are also presented. Furthermore, in rat preclinical studies, 3-SPA displayed 100% oral bioavailability and 25% brain penetration, indicating that the metabolite is well absorbed and crosses the blood-brain barrier. **Conclusions:** We have confirmed the endogenous presence of 3-SPA, the major metabolite of tramiprosate, in CSF of drug-naïve elderly patients with memory deficits due to a variety of neurodegenerative disorders. In patients with AD receiving tramiprosate, the levels of 3-SPA were up to 12.6-fold greater than in drug-naïve patients. In addition, 3-SPA displays potent anti-A β oligomer activity, inhibiting aggregation of A β 42 into small soluble oligomers with efficacy comparable to tramiprosate. 3-SPA displays excellent oral availability and brain penetration in rats, suggesting that the higher CSF concentrations of 3-SPA in human brain after oral administration of ALZ-801 or tramiprosate and subsequent conversion to 3-SPA, result from the penetration of 3-SPA metabolite into the CNS. These data suggest that 3-SPA is an endogenous agent with potential activity stabilizing the conformational flexibility of A β monomers that, in turn, inhibits A β misfolding and formation of soluble toxic A β oligomers in humans, thereby preventing the initial pathogenic step in the progression of Alzheimer's disease. Clinical improvements observed in AD patients in tramiprosate Phase 3 studies (Abushakra et al, 2018) may in part be explained by the therapeutic effects of excess levels of the metabolite in the brains of these patients. The potential protective role of 3-SPA in AD pathogenesis, disease progression, as well as its therapeutic role in AD and other neurodegenerative disorders, warrants further investigation. References: 1. Hey, JA, Kocis, P, Hort, J et al. *CNS Drugs* 2018. <https://doi.org/10.1007/s40263-018-0554-0>; 2. Abushakra S, Porsteinsson A, Scheltens P, et al. *J Prev Alzheimers Dis* 2017; 4:149-56

LBP26: NOVEL USE OF APTAMER LIBRARIES FOR PREDICTION OF AMYLOID STATUS FROM BLOOD SERUM. Gregory Penner¹, Soizic Lecocq¹, Anaëlle Chopin¹, Simone Lista^{2,3,4,5}, Andrea Vergallo^{2,3,4,5}, Enrica Cavedo^{2,3,4,5}, Francois-Xavier Lejeune⁴, Harald Hampel^{2,3,4,5} the INSIGHT-preAD study group and the Alzheimer Precision Medicine Initiative (APMI) ((1) *NeoNeuro SAS, Villejuif Bio Park, Villejuif, France*; (2) *AXA Research Fund & Sorbonne University Chair, Paris, France*; (3) *Sorbonne University, GRC n° 21, Alzheimer Precision Medicine (APM), AP-HP, Pitié-Salpêtrière Paris, France*; (4) *Brain & Spine Institute (ICM), INSERM U 1127, CNRS UMR 7225, Paris, France*; (5) *Institute of Memory and Alzheimer's Disease (IM2A), Department of Neurology, Pitié-Salpêtrière Hospital, AP-HP, Paris, France*)

Background: The development of effective treatments for Alzheimer’s disease (AD) is constrained by the capacity to screen potential AD patients for clinical trials, broadly and cost-effectively. Both amyloid and tau Positron Emission Tomography (PET) scans as well as cerebrospinal fluid (CSF) analysis of surrogate biomarkers of AD – including amyloid- β ($A\beta$) peptides, total tau (t-tau), tau phosphorylated at Thr181 (p-tau181), and neurofilament light chain (NFL) protein – provide prognostic ability, although they are too expensive to enable screening for AD in large preclinical populations. Blood analysis of these biomarkers achieved significant advances thanks to the development of novel methodologies, such as immunoprecipitation assays followed by mass spectrometry technology. The predictive capacity of these blood-based biomarkers decreases significantly as a function of time prior to the onset of cognitive dysfunction. At present, we developed a novel, alternative approach – in collaboration with the INSIGHT-preAD cohort – involving the application of enriched aptamer libraries as a means of mapping multiple pathological epitopes in blood, both rapidly and cost-effectively. **Objectives:** 1.) To demonstrate the association between blood (serum) aptamers binding to low frequency epitopes and brain amyloid status, as measured by amyloid-PET scan. 2.) To identify a subset of these serum aptamers via next generation sequencing (NGS)-based analyses. 3.) To apply this subset of serum aptamers as a novel diagnostic assay to better predict brain $A\beta$ accumulation status. **Methods:** We applied FRELEX selection to a random aptamer library consisting of 1016 sequences against a pool of serum from six cognitively normal (CN) brain $A\beta$ positive (CN-A+) individuals recruited from the INSIGHT-preAD. FRELEX is a selection method that does not require immobilization or knowledge of the selection targets. A pool of serum from six CN brain $A\beta$ negative (CN-A-) individuals from the same cohort was used for counter selection with the library in each selection round after the first one. After ten rounds of selection, aliquots of the enriched library were applied for a single round of positive selection against individual serum samples of 22 CN subjects (11 CN-A+ and 11 CN-A-). Each of these 22 selected libraries of aptamers was characterized by NGS analysis. The relative frequencies of the top 1,000 sequences in terms of copy number were correlated with amyloid status using sparse partial least squares – discriminant analysis (sPLS-DA). Based on this analysis a subset of 21 aptamers was defined as sufficient to obtain sensitivity and specificity of 1.0 on the 22 subjects with PLS-DA analysis and cross validation. These aptamers were divided into two subsets of 13 and 10 aptamers each with two aptamers being in common between the subsets. Both subsets were applied in a single round of FRELEX against serum from 42 CN subjects from the INSIGHT-preAD cohort (25 CN-A+, 17 CN-A-). The effect of the selection process on aptamer frequency was determined by qPCR analysis with specific primers for each aptamer. **Results:** Figure 1 provides the area predicted for each of the classes of amyloid status considered, with the locations of each of the 42 samples within these prediction areas. These predicted areas are not subject to the cross-validation analysis, only the first two dimensions are illustrated. Figure 2 provides the ROC curve following cross-validation analysis with 100 replications and 10 folds. The calculations are based on multivariate prediction methods with a threshold based on distance. The values provided are based on analysis across three principal components. Based on the cross-validation analysis, sensitivity was estimated as 0.80, specificity as 0.88, and accuracy as 0.83. AUC was 0.9153 in

one dimension, 0.9529 in two dimensions, and 0.9694 in three dimensions. **Conclusions:** Aptamers were identified that bound to target molecules that were present at higher concentrations in the blood (serum) of CN subjects with elevated levels of brain amyloid accumulation. The binding of these aptamers to their targets was evaluated by characterizing the effect of selection in individual serum samples on individual aptamer frequencies. This represents the first time to our knowledge that aptamer frequency has been used as a biomarker for any disease. The results reported within this study are comparable to results with known biomarkers with cognitively normal subjects. There are several advantages to this approach. 1.) The ability to identify “aptamarkers” within CN subjects at different time stages prior to the onset of cognitive dysfunction. 2.) The low cost and scalability of the analysis. 3.) The ability to combine “aptamarkers” from different trained libraries in one simultaneous analysis. 4.) The implicit capacity to continually improve the diagnostic process as the number of subjects analyzed increases through stratification of subgroups. 5.) The capacity to improve predictive power by using non-conforming subjects as a basis for the selection of additional diagnostic “aptamarkers”. We envision the application of this platform in synergy with other diagnostic tools including assays for known blood-based biomarkers and molecular genetic analyses.

Figure 1

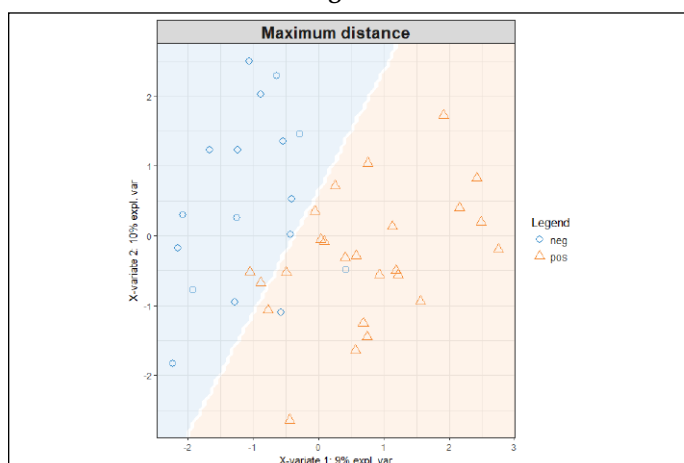
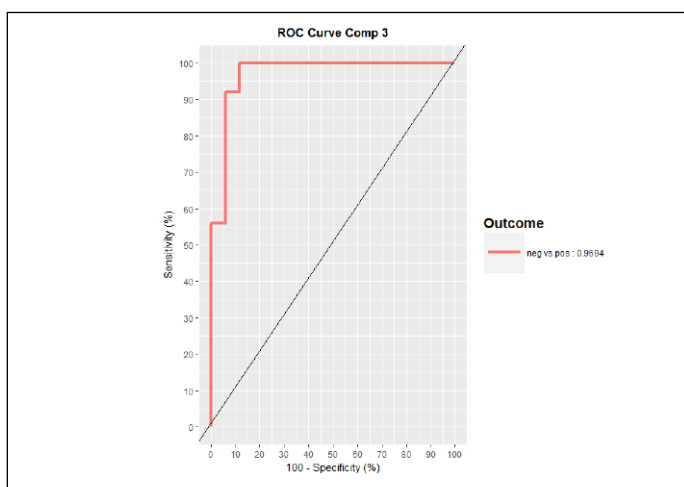

Figure 2



LBP27: NOVEL CEREBROSPINAL FLUID SYNAPTIC MARKERS IN ALZHEIMER'S DISEASE FOR POTENTIAL USE IN CLINICAL TRIALS.

Alberto Lleó^{1,2}, Raúl Núñez-Llaves^{2,3}, Daniel Alcolea^{1,2}, Martí Colom-Cadena^{2,3}, Laia Muñoz^{2,3}, Marta Querol-Vilaseca^{2,3}, Jordi Pegueroles^{2,3}, Lorena Rami⁴, Albert Lladó⁴, José L. Molinuevo⁴, Mikel Tainta⁵, Jordi Clarimón^{2,3}, Tara Spire-Jones⁶, Rafael Blesa^{1,2}, Juan Fortea^{1,2}, Pablo Martínez-Lage⁵, Raquel Sánchez-Valle⁴, Àlex Bayés^{7,8}, Olivia Belbin^{2,3} ((1) *Memory Unit, Neurology Department, Hospital de la Santa Creu i Sant Pau, Barcelona, Spain*; (2) *Centro de Investigación Biomédica en Red sobre Enfermedades Neurodegenerativas (CIBERNED), Madrid, Spain*; (3) *Biomedical Research Institute Sant Pau (IIB Sant Pau), Barcelona, Spain*; (4) *Alzheimer's Disease and Other Cognitive Disorders Unit, Neurology Department, Hospital Clínic-Institut d'Investigacions Biomediques August Pi i Sunyer (IDIBAPS), Barcelona, Spain*; (5) *Department of Neurology, Center for Research and Advanced Therapies, CITA-Alzheimer Foundation, San Sebastian, Spain*; (6) *Centre for Discovery Brain Sciences and UK Dementia Research Institute, University of Edinburgh*; (7) *Molecular Physiology of the Synapse Laboratory, Biomedical Research Institute Sant Pau (IIB Sant Pau), Barcelona, Spain*; (8) *Universitat Autònoma de Barcelona, 08193 Bellaterra (Cerdanyola del Vallès), Spain*)

Background: A biomarker of synapse loss, an early event in Alzheimer's disease (AD) pathophysiology that precedes neuronal death and symptom onset, would be a much-needed prognostic biomarker in living patients. With direct access to the brain interstitial fluid, the cerebrospinal fluid (CSF) is a potential source of synapse-derived proteins that should demonstrate changes that precede those of neuronal degeneration markers. Objectives: In this study, we aimed to identify and validate novel CSF biomarkers of synapse loss in AD. Methods: Combining shotgun proteomics of the CSF with an exhaustive search of the literature and public databases, we identified 210 synaptic proteins detectable in CSF, from which we selected 10 for further study. We confirmed the specific expression of 9 of the remaining proteins (Calsynytinin-1, GluR2, GluR4, Neurexin-2A, Neurexin-3A, Neuroligin-2, Syntaxin-1B, Thy-1, Vamp-2) at the human synapse using Array Tomography microscopy and biochemical fractionation methods. Using Selected Reaction Monitoring (SRM), we monitored these 9 synaptic proteins (20 peptides) in a cohort of CSF from cognitively normal controls and all pre-clinical and clinical AD stages (n=80). Results: Compared to controls, 19 peptides were co-elevated 1.3 to 1.6-fold (p<0.04) with the neurodegeneration marker, tau (measured by ELISA) in prodromal AD patients. Elevated levels of a GluR4 peptide were replicated (1.3-fold, p=0.04) in an independent cohort (n=60). Cross-cohort meta-analyses revealed a non-linear profile whereby, compared to controls, levels of Calsyntenin-1, GluR4, Neurexin-3A, Neuroligin-2 and Thy-1 were reduced 0.8-fold (p<0.05) in preclinical AD (reduced synaptic density) but elevated 1.2 to 1.4-fold (p<0.04) in clinical AD when neurodegeneration is widespread (neurodegeneration). Conclusions: This is the first study to demonstrate changes in CSF levels of synaptic proteins that precede markers of neurodegeneration in AD. We propose that these proteins could improve enrichment and monitoring of drug efficacy in clinical trials for AD.

Figure 1

Cox proportional-hazards analyses-comparisons across ATN categories of AD. Progression from MCI(ADNI1/GO/2, N=505) to a clinical diagnosis of dementia of the AD type

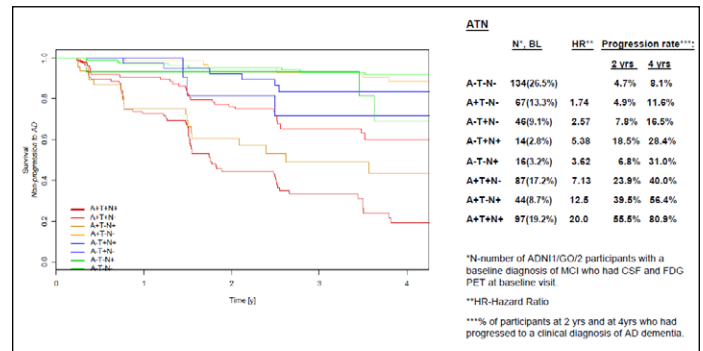

Table 1

Annual rates of decline in MMSE, CDRsob and FAQ in MCI(ADNI1/GO/2, n=487) participants

	N	MMSE	CDRsob	FAQ
A-T-N-	126	-0.121±1.17	0.032±0.56	0.178±1.13
A-T-N-	64	-0.308±0.96	0.167±0.46	0.486±1.48
A-T-N-	44	-0.314±0.82	0.152±0.40	0.143±1.73
A-T-N+	14	-0.582±1.67	0.550±1.11	1.675±2.51
A-T-N+	15	-0.141±0.75	0.441±0.77	0.956±2.93
A-T-N+	84	-0.856±2.00	0.561±0.82	1.417±3.585
A-T-N+	44	-1.389±1.67	0.86±1.01	2.753±3.87
A-T-N+	96	-1.76±2.03	1.35±1.21	4.014±3.39

Each annual rate of decline is the mean slope ± SD value for the participants in each ATN category

LBP28: DIMINISHED PLATELET-DERIVED HSA-MIR-150-5P EXPRESSION AS BIOMARKER FOR DEMENTIA WITH LEWY BODIES VERSUS ALZHEIMER'S DISEASE.

Katrin Beyer¹, Ana Gámez-Valero^{1,2}, Jaume Campdelacreu³, Dolores Vilas⁴, Lourdes Ispuerto⁴, Jordi Gascón-Bayarri³, Ramón Reñé³, Ramiro Álvarez⁴, Maria P Armengol⁵, Francesc E. Borràs² ((1) *Department of Pathology, Health Sciences Research Institute Germans Trias i Pujol, Universitat Autònoma de Barcelona, Spain*; (2) *REMAR-IVECAT group, Health Sciences Research Institute Germans Trias i Pujol, Badalona, Spain*; (3) *Department of Neurology, Hospital Universitari de Bellvitge, L'Hospitalet de Llobregat, Spain*; (4) *Department of Neurology, Hospital Universitari Germans Trias i Pujol, Badalona, Spain*; (5) *Genomic and Microscopy facilities, Institut Investigació Ciències de la Salut Germans Trias i Pujol (IGTP), Badalona (Barcelona), Spain*)

Background: Dementia with Lewy bodies (DLB) is after Alzheimer's disease (AD) the second most common cause of dementia and belongs, together with Parkinson's disease (PD), to the group of Lewy body disorders. All three show an important clinical and neuropathological overlap difficulting correct DLB diagnosis and leading to an elevated misdiagnosis rate of DLB. Diagnostic biomarkers are not only urgently needed to improve diagnosis and treatment but also to assure correct diagnosis of patients to be included in clinical trials for AD, DLB or PD drug testing. The search of blood biomarkers is constantly increasing including both cell free circulating and cell-based biomarkers. Platelets are anucleate cells containing rough endoplasmic reticulum, ribosomes, mitochondrial and apoptotic systems, and neuron-like enzymatic pathways. MicroRNAs (miRNAs) regulate the expression of coding genes and the existence of an almost complete and functional miRNA pathway has been found in platelets. The presence of

miRNA in these anucleate cells, converts them into a promising non-invasive source of miRNAs as biomarkers for several disorders. **Objectives:** To analyze the suitability of platelet miRNA content as promising source of biomarkers for DLB by examining the complete platelet miRNA profile. To find out which specific miRNAs are differentially expressed in DLB compared to controls. To determine if differential miRNA profiles are detectable also in independent cohorts and by other technologies, if these profiles are specific for DLB or a common feature for neurodegenerative disorders, and if they are similar in whole blood or platelet specific. **Methods:** DLB patients (n=33, mean age: 71.8 years, age range: 57-86 years, male:female ratio 1.4:1), AD patients (n=10, mean age: 73.9, age range: 65-85 years, male:female ratio 1:1.5) with a Global Deterioration Scale of 4.3 ± 1.2 degrees and control subjects (n=37, mean age 72.0 years, age-range 61-85 years, male:female ratio 0.8:1) were included in this study. For platelet purification, 12-15 mL of blood were collected in sodium citrate pre-treated tubes following standard procedures to minimize coagulation and platelet activation. miRNAs were extracted from platelets using the mirVana Paris Kit and from whole blood by the use of the PAXgene Blood miRNA Kit 50, v2. During the discovery phase, miRNAs from 7 DLB and 7 control samples were used for library preparation. Library clustering and sequencing were performed on an Illumina Sequencer. Reads were mapped to miRNA sequences using the Bowtie2 algorithm and differential expression analyses were carried out with Lilliefors' composite goodness-of-fit, Jarque-Bera hypothesis and Shapiro-Wilk tests. During the validation phase, reverse transcription was carried out with the MiRCURY LNATM Universal cDNA synthesis Kit, and quantitative real-time PCR with ExiLENT SYBR Green Master Mix by miRNA LNA technology Pick-&-Mix PCR pre-designed panels on a LightCycler 480. miRNA expression changes were analyzed by the $\Delta\Delta Ct$ method and two-tailed unpaired T-test to compare Cp values between control and disease groups. Kruskal-Wallis non-parametric test was used for multiple comparisons. Diagnostic potential was assessed using the area under the ROC curve (AUC) calculated by SPSS Statistics 21 and GraphPadPrism 7. **Results:** Platelet miRNA profiling unveiled 534 miRNAs of which 304 had been previously reported as associated to platelets. After normalization of the NGS data, 22 miRNAs showed differential expression between DLB and healthy controls and were validated by qPCR in independent DLB and control cohorts (n=14, each). The majority were down-regulated in the DLB group compared to controls, but the most important decrease was found for hsa-miR-150-5p in DLB vs controls (0.03 ± 0.01 vs. 0.76 ± 0.34 ; $p < 0.0001$). The 10 most differentially expressed miRNAs (hsa-miR-150-5p, hsa-miR-7d-5p, hsa-miR-142-3p, hsa-miR-26b-5p, hsa-miR-139-5p, hsa-miR-146a-5p, hsa-miR-128-3p, hsa-miR-6747-3p, hsa-miR-132-5p and hsa-miR-25-3p) were analyzed in other independent cohorts of 12 DLB patients and 10 controls from a different hospital, and 10 AD patients. Hsa-miR-150-5p expression levels could be confirmed as significantly decreased in DLB compared to controls, but especially compared to AD (Fig. 1A). ROC curve analyses taking into account hsa-miR-150-5p expression changes for each cohort of both validation studies returned an area under curve (AUC) of 0.87 of specificity and sensitivity, distinguishing between DLB (n=26) and controls (n=24, Fig. 1B), and of 1.00 distinguishing between DLB and AD (n=10, Fig. 1C). Hsa-miR-150-5p expression was not significantly different between AD and healthy controls. Hsa-miR-150-5p expression

in whole blood did not differ between DLB, AD and controls, confirming platelet-specific expression changes for this miRNA. **Conclusions:** Platelet-derived hsa-miR-150-5p shows high sensitivity and specificity, to distinguish between DLB and AD, and represents a diagnostic biomarker for DLB. The detection of this single miRNA in platelets represents a non-invasive and easy procedure. Its application may substantially improve diagnostic accuracy for DLB and the success of clinical trials in DLB but also AD.

Figure 1

Platelet-derived hsa-miR-150-5p in DLB, AD and controls. (A) Relative expression, (B) ROC curve analysis for DLB vs controls, (C) ROC curve analysis for DLB vs AD.

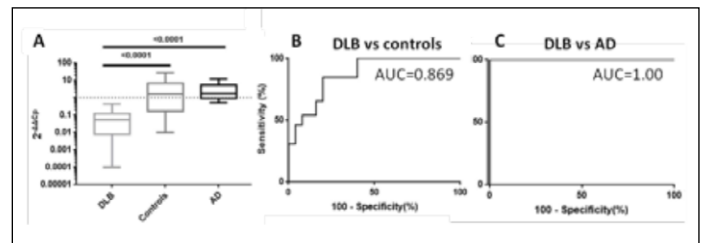

LBP29: DEVELOPMENT OF POLYGENIC RISK SCORES (PRS) FOR COMMON NEUROPATHOLOGY. Julie Collens, Mike Nalls, Marcel van der Brug (*Vivid Genomics, Inc. San Diego, CA, USA*)

Background: Amyloid-PET imaging and CSF amyloid testing are common diagnostic, selection tools for patient selection in clinical trials for Mild cognitive impairment (MCI) due to Alzheimer's disease. In practice the implementation of these screening tests has been expensive, slow and a significant source of patient dropout. **Objectives:** To develop a novel PRS to predict the presence of Alzheimer's and co-morbid pathologies (amyloid, Lewy bodies, CAA, and others). In addition to amyloid, Lewy bodies are present in >50% of AD cases, to varying densities and distributions. CAA/Vascular lesions, white matter rarefaction and TDP-43 pathologies are also common. Each of these can contribute to cognitive impairment and neurodegeneration, and are likely to be a significant source of heterogeneity in clinical response and disease progression in therapeutic trials. Identifying and understanding how this heterogeneity is related to the molecular pathways driving disease can enable stratified approaches to drug development, and development of a diagnostic PRS with clinical utility. **Methods:** Our polygenic risk score (PRS) for detecting amyloid among patients with mild cognitive impairment were developed from in-house (n=1307) brain samples with histopathology for amyloid, Tau, Lewy bodies, and publicly available data (ADNI, n=535) as a proof of concept for using genetics and 10 separate machine learning methods (C5, EARTH, GBM, GLM, LogitBoost, NB, NNET, RF, SVM, xgbDART, xgbTREE) to identify a polygenic classifier with optimal performance in detecting neurodegenerative pathologies. **Results:** We have developed a PRS that incorporates age, sex, MCI status and 167 SNPs to stratify patients by the likelihood of underlying pathology; providing a way to molecularly define sub-groups of patients with AD. Our prototype classifier receiver operator curve shows the accuracy of an integrative predictive model in distinguishing amyloid positive MCI subjects from amyloid negative MCI subjects, as

determined by PET scan (Sensitivity 95% CI = 85-73, Specificity 95% CI = 80-69, AUC 95% CI = 83-77). Our data suggest that higher levels of accuracy can be achieved by incorporating additional genetic data. **Conclusions:** Using polygenic risk score (PRS) assessment it is possible to enrich for amyloid positive individuals prior to expensive and invasive confirmatory tests. This is particularly important in trials recruiting early stage or pre-symptomatic subjects where prevalence of amyloid positivity is low (46% of all MCI) and the presence of non-amyloid pathologies contributing to impairment is variable. Defining these sub-groups of disease directly addresses two major bottlenecks in therapeutic development; (1) Non-invasive, rapid diagnostics to enrich for amyloid positive patients during clinical trial enrollment (2) Reduction in heterogeneity in underlying pathologies that could affect therapeutic response and rate of disease progression.

LBP30: THE ITALIAN INTER-SOCIETAL CONSENSUAL ALGORITHM FOR THE BIOMARKER-BASED DIAGNOSIS OF MILD COGNITIVE IMPAIRMENT.

Marina Boccardi^{1,2}, Valentina Nicolosi¹, Cristina Festari^{1,3}, Angelo Bianchetti^{4,5}, Stefano Cappa^{1,6,7}, Davide Chiasserini^{8,9}, Andrea Falini¹⁰⁻¹³, Ugo Paolo Guerra^{14,15}, Flavio Nobili¹⁵⁻¹⁷, Alessandro Padovani^{7,18}, Giulia Maria Sancesario^{9,19}, Francesca Benedetta Pizzini^{13,20}, Alberto Beltramello^{13,21}, Marcello Ciaccio^{9,22}, Orazio Schillaci^{15,23}, Marco Trabucchi^{5,24}, Fabrizio Tagliavini²⁵, Giovanni Battista Frisoni^{1,2,26} ((1) *Laboratory of Neuroimaging and Alzheimer's Epidemiology, IRCCS Istituto Centro San Giovanni di Dio Fatebenefratelli, Brescia, Italy*; (2) *LANVIE - Laboratory of Neuroimaging of Aging, University of Geneva, Geneva, Switzerland*; (3) *University of Brescia, Department of Molecular and Translational Medicine, Brescia, Italy*; (4) *Medicine and Rehabilitation Department, Istituto Clinico S. Anna, Brescia, Italy*; (5) *Italian Psychogeriatric Association (AIP), Brescia, Italy*; (6) *NEtS Center, Scuola Universitaria Superiore IUSS, Pavia, Italy*; (7) *Italian Society of Neurology - Association for the Study of the Dementias (SINdem), Italy*; (8) *Section of Neurology, Department of Medicine, University of Perugia, Perugia, Italy*; (9) *Italian Society of Clinical Biochemistry and Clinical Molecular Biology - Laboratory Medicine (SiBioC), Italy*; (10) *Division of Neuroscience, IRCCS San Raffaele, Milan, Italy*; (11) *Vita-Salute San Raffaele Università, Milan, Italy*; (12) *Neuroradiology Unit, IRCCS San Raffaele hospital, Milan, Italy*; (13) *Italian Association of Neuroradiology (AINR), Italy*; (14) *Department of Nuclear Medicine, Poliambulanza Foundation, Brescia, Italy*; (15) *Italian Association of Nuclear Medicine (AIMN), Italy*; (16) *Clinical Neurology, Dept of Neuroscience (DiNOGMI), University of Genoa, Italy*; (17) *IRCCS Ospedale Policlinico San Martino, Genova, Italy*; (18) *Neurology Clinic, Department of Clinical and Experimental Sciences, Brescia, Italy*; (19) *Department of Clinical and Behavioural Neurology, Santa Lucia Foundation, Rome, Italy*; (20) *Department of Neuroradiology, General Hospital, Verona, Italy*; (21) *Dipartimento di Diagnostica per Immagini, IRCCS Ospedale Classificato «Sacro Cuore - Don Calabria», Negrar, Verona*; (22) *Department of Biopathology and Medical Biotechnologies, University of Palermo, Palermo, Italy*; (23) *Department of Biomedicine and Prevention, University Tor Vergata, Rome, Italy*; (24) *Tor Vergata, Rome University, Rome, Italy*; (25) *Division of Neurology V/Neuropathology, Fondazione IRCCS Istituto Neurologico "Carlo Besta", Milan, Italy*; (26) *Memory Clinic, University Hospital, Geneva - Switzerland*)

Background: Introduction: Biomarkers enable the etiopathological diagnosis of dementing neurodegenerative disorders in vivo, but the assessment of their comparative

combined and incremental diagnostic value is still ongoing (Frisoni et al., 2017). In Italy and elsewhere, biomarkers are prescribed based on logistical issues (waiting lists, perception of invasiveness, availability and proximity of services) rather than clinical evidence and patient-related variables (Bocchetta et al., 2015; Riello et al., 2003). **Objectives:** To define a consensual biomarker-based diagnostic algorithm guiding clinicians in the prescription of biomarkers while comparative combined and incremental diagnostic studies are ongoing. **Methods:** Referents expert in the pertinent clinical or reporting procedures participated to a Delphi procedure representing five Italian Scientific Societies: SINdem (Italian Society of Neurology - Association for the Study of the Dementias), AIP (Italian Psychogeriatric Association), AIMN (Italian Association of Nuclear Medicine), AINR (Italian Association of Neuroradiology), and SiBioC (Italian Society of Clinical Biochemistry and Clinical Molecular Biology - Laboratory Medicine). Consensus was defined as 80% of consistent responses. **Results:** Panelists defined the context of use as the biomarker-based etiopathological diagnostic procedure for patients with Mild Cognitive Impairment (MCI) in memory clinics, and the theoretical framework that of the 2011 NIA-AA diagnostic criteria (Albert et al., 2011). Panelists achieved consensus on the definition of the diagnostic algorithm within six voting rounds, conducted from June 2017 to May 2018. The final algorithm comprises three levels of examination. The algorithm includes: I) At T0, clinical and general cognitive assessment, blood examination and magnetic resonance imaging (MRI) with both exclusionary and inclusionary role; II) at T1, detailed assessment of cognitive function, nutritional status, depression, anxiety, and daily function; III) at T2, based on patient's age and on the consistency between neuropsychological and MRI findings, CSF and FDG-PET investigation in all cases with inconsistent findings, and only CSF in cases with consistent findings and below age 85. Cases with typical or atypical Parkinsonism should undergo DaT-SPECT only. IV) At T3, the physician can still resort to the more expensive amyloid-PET if the diagnosis is still uncertain and liable to improvement with this exam. **Conclusions:** This is the first Italian inter-societal consensus on a diagnostic algorithm involving multiple biomarkers for a cost-effective etiopathological diagnosis of MCI in memory clinics. Although still largely based on expert consensus, we propose this diagnostic algorithm as interim recommendations maximizing the informative value over the costs of the diagnostic procedure. Further studies will provide the quantitative data required to define diagnostic algorithms fully based on evidence. **References:** Frisoni G.B. et al. Strategic roadmap for an early diagnosis of Alzheimer's disease based on biomarkers. *Lancet Neurology* 2017;16(8):661-676. Albert M.S. et al. The diagnosis of mild cognitive impairment due to Alzheimer's disease: Recommendations from the National Institute on Aging-Alzheimer's Association workgroups on diagnostic guidelines for Alzheimer's disease. *Alzheimer's & Dementia* 2011; 7(3), 270-279. Bocchetta M. et al. The use of biomarkers for the etiologic diagnosis of MCI in Europe: An EADC survey. *Alzheimer's & Dementia* 2015; 11(2), 195-206.e1. Riello R. et al. Prescription practices of diagnostic imaging in dementia: a survey of 47 Alzheimer's Centres in Northern Italy. *International Journal of Geriatric Psychiatry* 2003; 18(7), 577-585.

LBP31: SECONDARY STRUCTURE OF A β AS BLOOD BIOMARKER. Klaus Gerwert (*Department of Biophysics Ruhr University Bochum, Germany*)

Background: A precise, cheap and minimally invasive molecular blood biomarker for early diagnosis of Alzheimer's disease is required and crucial for future therapy. Here, the Amyloid- β (A β) secondary structure distribution was investigated in blood of participants of an Alzheimer cohort, an prodromal cohort and non-symptomatic participants of a large prospective population-based cohort using an immunoinfrared-sensor, the "iR-sense". 1,2,3 The A β burden of the brain correlates with this blood biomarker and AD is predicted in average 8 years before clinical diagnosis with an overall accuracy of 88%.³ Now, sensitivity and specificity is even increased to 87% and 97% respectively by measuring in addition in CSF the secondary structure distribution of A β and tau. The obtained results demonstrate that a label-free and reliable blood biomarker for preclinical AD has probably been found. 1) Nabers, A., Ollesch, J., Schartner, J., Kötting, C., Genius, J., Hausmann, U., Klafki, H., Wiltfang, J., Gerwert, K. An infrared sensor analysing label-free the secondary structure of the A β peptide in presence of complex fluids. *J Biophotonics*. 2016 Mar;9(3):224-34; 2) Nabers, A., Ollesch, J., Schartner, J., Kötting, C., Genius, J., Hafermann, H., Klafki, H., Gerwert, K., Wiltfang, J. Amyloid- β -Secondary Structure Distribution in Cerebrospinal Fluid and Blood Measured by an Immuno-Infrared-Sensor: A Biomarker Candidate for Alzheimer's Disease *Anal. Chem.* 2016, 88, 2755-2762; 3) Nabers, A., Perna, L., Lange, J., Mons, U., Schartner, J., Güldenhaupt, J., Saum, K.-U., Janelidze, S., Hollecsek, B., Rujescu, D., Hansson, O., Gerwert, K., Brenner, H. Amyloid blood biomarker detects Alzheimer's disease *EMBO Molecular Medicine* (2018)

LBP32: BDNF AS A BIOMARKER FOR THE EFFECTS OF P38 MAPK α INHIBITION ON IL-1 β -INDUCED IMPAIRMENT OF HIPPOCAMPAL SYNAPTIC PLASTICITY. John Alam¹, Charlotte Teunissen², Niels Prins^{3,4}, Hui-May Chu⁵, Philip Scheltens³ ((1) *EIP Pharma Inc, Cambridge MA, USA*; (2) *Department of Clinical Chemistry, VU University Medical Center, Amsterdam, NL*; (3) *Department of Neurology and Alzheimer Centre, VU University Medical Center, Amsterdam, NL*; (4) *Brain Research Center, Amsterdam, NL*; (5) *Anoixis Corporation, Framingham MA, USA*)

Introduction and Objectives: Neflamapimod is a highly selective brain penetrant oral inhibitor of the kinase activity of the alpha isoform of p38 mitogen-activated protein kinase (MAPK α). In preclinical studies, neflamapimod reversed spatial learning deficits in the Morris-Water-Maze test with 3 weeks of dosing. In 6- and 12-week duration phase 2a clinical studies in patients with early Alzheimer's disease (AD) demonstrated within-subject improvement in episodic memory function (Scheltens et al, ACTN, 2018; CTAD, 2016 & 2017). The combined preclinical and clinical results suggest that neflamapimod has potential for reversing impaired synaptic dysfunction in the hippocampus. Neflamapimod is currently in a phase 2b clinical study ("REVERSE-SD Study"), which has the primary objective of confirming in a placebo-controlled setting the effects of neflamapimod on episodic memory as assessed by the Hopkins Verbal Learning Test. As dysregulated interleukin-1 β (IL-1 β) expression has been extensively documented in the scientific literature to impair

hippocampal synaptic plasticity via p38 MAPK dependent pathways (Lynch, 2011; Tong et al, 2012; Prieto et al, 2015), one mechanistic explanation for the preclinical and clinical results with neflamapimod is that the drug achieves its effects through reversing IL-1 β induced impairment of hippocampal synaptic plasticity. Further, as IL-1 β overexpression in various animal models also suppresses brain-derived neurotrophic factor (BDNF) expression in the hippocampus (Barrientos et al, 2004; Patterson, 2015; Tanaka et al, 2018) we postulated that levels of BDNF could be associated with the extent of p38 MAPK α dependent IL-1 β signaling and accordingly measured levels of BDNF in stored samples from preclinical and clinical studies of neflamapimod. In addition, the clinical sample results were correlated to clinical outcomes. **Methods:** Preclinical: Brain homogenates were available from a study of neflamapimod to promote recovery after transient ischemia-induced stroke in young rats (Alam et al, http://n.neurology.org/content/86/16_Supplement/P5.228). In the main study, results neflamapimod dosing for six weeks, starting 48 hours after stroke, led to dose-dependent improvement compared to vehicle-administered controls in neurologic function, as assessed by modified Neurologic Severity Scale. IL-1 β and BDNF protein levels were assessed by the respective Quantikine[®] ELISA kits (R&D Systems). Brain samples from the aged rat study were no longer available. Clinical: Plasma samples were available from a 12-week treatment study of neflamapimod in patients with Early AD; the clinical results of which are published (Scheltens et al, ACTN, 2018). Plasma BDNF protein levels in the first ten subjects in this study were quantitated utilizing the SOMAscan[®] platform and reported herein. Plasma BDNF levels were also quantitated utilizing an immunoassay platform and reported in the publication; however, the within-subject and inter-subject variability in that assay precluded any reliable assessment of treatment effect (Supplemental Table 3, Scheltens et al, 2018). **Results:** Preclinical: In the brain homogenates from stroked rats, IL-1 β protein levels were variably increased on the injured hemisphere and undetectable on the uninjured side. There was a trend towards lower BDNF levels in the injured hemisphere and statistically significant dose-dependent increases in BDNF protein levels in both hemispheres ($p < 0.05$ for injured hemisphere and $p < 0.01$ for uninjured hemisphere). **Clinical:** Mean BDNF Somascan signal at baseline (pre-treatment) in the clinical study was 438 (s.e.m.=28) and 497 (47) at Day 84 of neflamapimod treatment ($p = 0.04$ for increase from baseline to Day 84). The percentage change in BDNF signal in individual subjects was also correlated to individual subject 12-hour plasma drug exposure ($p = 0.04$, $r^2 = 0.42$). In a secondary analysis of all 1322 analytes assessed in the Somascan assay, only two other analytes demonstrated a statistically significant correlation between extent of change and plasma drug exposure: Fc ϵ R2 (low-affinity receptor for IgE; $p = 0.02$, $r^2 = 0.49$) and carboxypeptidase B2 ($p = 0.04$, $r^2 = 0.43$). Finally, the percentage of change in BDNF signal in individual subjects was correlated to the extent of change (improvement) in combined immediate and delayed recall composites in the Wechsler Memory Scale ($p = 0.007$, $r^2 = .67$). **Discussion and Conclusion:** p38 MAPK α inhibition with neflamapimod increases BDNF protein levels in the brain after ischemic stroke in rats, and the preliminary evidence utilizing the Somascan assay suggests plasma BDNF levels also increase after neflamapimod treatment in subjects with early AD. Combined with the scientific literature on the role of p38 mediated IL-1 β signaling in the modulating of synaptic plasticity and BDNF levels, the correlation between

extent of increase in plasma BDNF levels with improvement in immediate and delayed recall (i.e. episodic memory function) support a mechanistic model whereby inhibition of IL-1 β signaling contributes to the potential therapeutic effect of neflamapimod on episodic memory.

LBP33: IMPACT OF PRE-ANALYTICAL SAMPLE HANDLING ON ELECSYS AB40, AB42 AND TTAU IMMUNOASSAYS IN PLASMA. Malgorzata Rozga¹, Tobias Bittner², Richard Batrla-Utermann³, Johann Karl¹ ((1) Roche Diagnostics GmbH, Penzberg, Germany; (2) Genentech, A member of the Roche Group, Basel, Switzerland; (3) Roche Diagnostics International AG, Rotkreuz, Switzerland)

Background: Analyses of cerebrospinal fluid (CSF) biomarkers A β 40, A β 42 and tTau are part of the diagnostic criteria of Alzheimer's disease (AD). In the last decade, however an increasing interest can be observed for AD specific blood-based biomarkers. The greatest advantage of blood biomarkers is that the collection of blood is less invasive and a more cost-effective and time-efficient procedure. In this regard, blood-based biomarkers for AD are often considered optimal pre-screening tools to rule out subjects who are not in need of more expensive and invasive procedures such as PET imaging or CSF collection. The experience with CSF AD biomarkers, however shows that pre-analytical factors linked to the procedure of sample handling and processing before measurement are an important source of variability and misclassification of patients in clinical routine hampering the establishment of universal cut-off values and consequently between-lab and between-study comparisons. **Objectives:** The aim of this study was to explore the influence of common confounding pre-analytical factors including circadian rhythm, type of collection tube, type of anticoagulant, time to blood centrifugation, time and temperature of plasma storage prior to measurement, as well as number of freeze-thaw cycles on the measurement of A β 1-40, A β 1-42 and tTau in human plasma. **Methods:** The plasma concentrations of A β 40, A β 42 and tTau were quantified using fully automated Roche Elecsys assays on the cobas e601 analyzer. **Results:** We show that measured levels of plasma A β 40, A β 42 and tTau are not affected by up to 3 freeze-thaw cycles or circadian rhythm. Also the material and size of a collection tube had no impact, but tTau level varied by as much as 70 % depending on the type of anticoagulant used in those tubes. Furthermore, the concentrations of A β 40 and A β 42 but not tTau were strongly influenced by time to centrifugation of whole blood after withdrawal and plasma separation. The levels of Ab40 and Ab42 started decreasing already after 1 hour of blood draw and were reduced by as much as ~5% and 10% after 2 and 6 hours of collection, respectively. **Conclusions:** Taken together, the results of our experiments provide guidelines to generate standardized procedures for collection, handling and storage of blood samples for the reliable analysis of AD specific biomarkers in plasma.

LBP34: AGREEMENT BETWEEN VISUAL AMYLOID PET AND CEREBROSPINAL FLUID AB1-42, AB1-40, T-TAU AND P-TAU ON THE LUMIPULSE G FULLY AUTOMATED PLATFORM. Alberto Lleó^{1,2}, Jordi Pegueroles^{1,2}, Laia Muñoz^{1,2}, Valle Camacho³, Diego López-Mora³, Alejandro Fernández-León³, Nathalie Le Bastard⁴, Els Huyck⁴, Alicia Nadal⁵, Verónica Olmedo⁵, Víctor Montal^{1,2}, Eduard Vilaplana^{1,2}, Rafael Blesa^{1,2}, Juan Fortea^{1,2}, Daniel Alcolea^{1,2} ((1) Sant Pau Memory Unit,

Neurology Department, Hospital de la Santa Creu i Sant Pau - Biomedical Research Institute Sant Pau - Universitat Autònoma de Barcelona, Barcelona, Spain; (2) Centro de Investigación Biomédica en Red de Enfermedades Neurodegenerativas. CIBERNED, Spain; (3) Nuclear Medicine Department, Hospital de la Santa Creu i Sant Pau - Biomedical Research Institute Sant Pau - Universitat Autònoma de Barcelona, Barcelona, Spain; (4) Fujirebio Europe NV, Gent, Belgium; (5) Fujirebio Iberia, SLU, Barcelona, Spain)

Background: Biomarkers for Alzheimer's disease (AD) allow an earlier and more accurate diagnosis of the disease. Different kinds of biomarkers have been investigated in AD, but cerebrospinal fluid (CSF) biomarkers and imaging techniques are those with a wider implementation. CSF biomarkers are relatively inexpensive, but they require a lumbar puncture and do not provide information about the distribution of plaques and tangles. On the other hand, molecular imaging markers as amyloid PET are less invasive and provide topographical knowledge of the distribution of pathology but they are expensive and, in some cases, not easily accessible. With traditional ELISA assays, the analysis of CSF biomarkers has shown large inter-laboratory variability, ranging from 20% to 30%. However, fully automated platforms have recently been developed and have proven higher accuracy and reproducibility. Our objective was to determine the agreement of 18F-Florbetapir PET imaging with four CSF biomarkers of AD (A β 1-42, A β 1-40, tTau and pTau) measured on the fully automated LUMIPULSE G600II platform and their ratios (A β 1-42/A β 1-40, A β 1-42/tTau and A β 1-42/pTau). **Methods:** We included 94 participants from the Sant Pau Initiative on Neurodegeneration (SPIN) cohort with available CSF samples and 18F-Florbetapir PET imaging. A β 1-42, A β 1-40, tTau and pTau were quantified directly in the storage tubes containing 0.5ml of CSF by the LUMIPULSE G600II. We analyzed all four analytes in the same run for each sample, and we used the same batch of kits, reagents and immunoassays for each biomarker. PET data were acquired using a Philips Gemini TF scan 50 minutes after injection of 370mBq of 18F-Florbetapir. All images were visually rated as positive or negative by three expert readers that were blind to clinical diagnosis and to CSF biomarker results. We performed receiver operating characteristic (ROC) analysis for all biomarkers and their ratios with A β 1-42 to calculate areas under the curve (AUC). For biomarkers and ratios that showed AUC higher than 0.70, we determined positive and negative percent agreement and calculated optimal cutoffs maximizing their Youden J index. We also calculated the overall percent agreement of CSF biomarker cutoffs with the amyloid PET visual interpretation. **Results:** Of 94 participants, 63% were amyloid-positive and 37% amyloid-negative. Their clinical diagnosis were mild cognitive impairment (n=9), AD dementia (n=26), other dementias or neurodegenerative diseases (n=53) and cognitively normal controls (n=6). Figure 1A illustrates ROC curves for individual biomarkers. Of them, tTau and pTau had the highest accuracy and yielded AUC of 0.80 (95% CI 0.70-0.89, p<0.001) and 0.84 (95% CI 0.75-0.93, p<0.001), respectively. A β 1-42 had fair accuracy with an AUC of 0.76 (95% CI 0.65-0.86, p<0.001), and A β 1-40 was not useful for the detection of the visual status of amyloid PET (AUC 0.59; 95% CI 0.47-0.71, p=0.134). As shown in Figure 1B, the combination of A β 1-42 with a second analyte resulted in increases of accuracy reaching AUC of 0.86 for A β 1-42/A β 1-40 (95% CI 0.77-0.96, p<0.001), 0.87 for A β 1-42/tTau (95% CI 0.78-0.95, p<0.001) and 0.88 for A β 1-42/pTau

(95% CI 0.79-0.97, $p < 0.001$). The election of optimal cutoffs was based on higher Youden indices peaks. In the case of single biomarkers, A β 1-42, tTau and pTau, peaks were at 1338pg/ml, 456pg/ml and 63pg/ml, respectively. As shown in Figure 2, these cutoffs had an overall percent agreement with visual-based amyloid PET classification of 79%, 78% and 81%. For the ratios A β 1-42/A β 1-40, A β 1-42/tTau and A β 1-42/pTau, optimal cutoffs were determined at 0.094, 2.37 and 22.1. These cutoffs had an overall percent agreement with visual-based amyloid PET of 84%, 81% and 87%, respectively. **Conclusions:** Single CSF biomarkers A β 1-42, tTau and pTau, but not A β 1-40, measured on the LUMIPULSE G600II platform had a good diagnostic agreement with visual assessment of amyloid PET. The combination of A β 1-42 with either A β 1-40, tTau or pTau improved their diagnostic agreement. In our study, optimal cutoffs for A β 1-42, tTau and pTau were 1338pg/ml, 456pg/ml and 63pg/ml, although values for A β 1-42 may change once this analyte is standardized to certified reference material, process currently under development.

Figure 1

Receiver Operating Characteristic analysis of single (A) and combined (B) CSF biomarkers' diagnostic utility to detect amyloid visual status

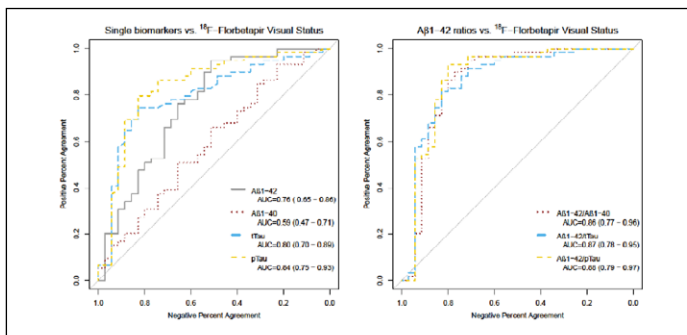

AUC: Area under the curve.

Figure 2

Agreement between amyloid PET imaging and CSF biomarkers on the LUMIPULSE G fully automated platform

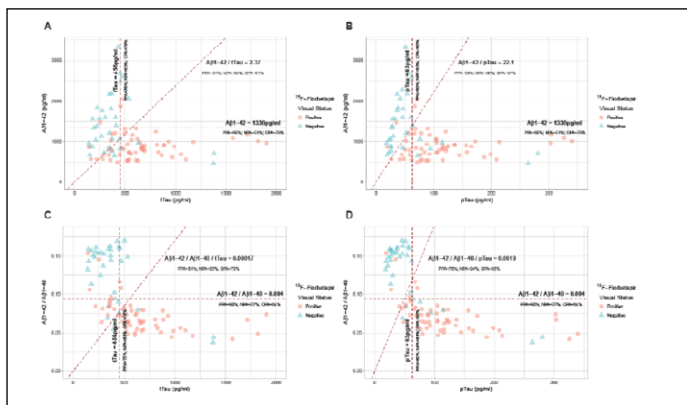

Dashed lines indicate cutoffs with maximum Youden J Index in the Receiver Operating Characteristic analysis. PPA: Positive Percent Agreement; NPA: Negative Percent Agreement; OFA: Overall Percent Agreement

LBP35: DOES NON-DISCLOSURE OF APOE GENOTYPING PREVENT SUBJECT INTEREST OR PARTICIPATION IN CLINICAL TRIALS? Sean Stanton¹, Vishnukartik Nitta², Jessica Branning² ((1) LifeCore Solutions, Winter Park, USA; (2) ClinCloud, LLC, Orlando - USA)

Background: Alzheimer's disease (AD) clinical trials have begun to focus on individuals with mild cognitive impairment (MCI)/mild AD and asymptomatic individuals, making the early identification of subjects with mild symptoms very important. We have developed a prescreening protocol, consisting of a cognitive testing battery, coupled with intensive medical history review, and optional APOE genetic testing. APOE is the prominent genetic risk factor associated with the development of AD and therefore has become an important screening marker. Conventional genotyping is generally performed at a central lab and requires up to several weeks to receive the result. Conventional genotyping, in screening for at-risk individuals, can lead to enrollment delays. To address this in our pilot study, we used a rapid, on-site APOE test. There is much debate surrounding the topic of genetic risk disclosure to an individual. It has been thought that disclosing genetic risk factors (such as APOE) causes anxiety and stress upon an individual, especially in the absence of any treatment. Research done by the REVEAL group has shown that genetic results can be safely disclosed to an individual when done in an educational and supportive setting (e.g., genetic counselling, pre-disclosure sessions, etc.). However, this generally requires more extensive informed consent and research protocols as well as proper patient education. This requires time and resources that not every clinic may have. By contrast, consent forms and research protocols are often simpler when genetic results are not disclosed. We endeavor to explore whether genetic disclosure of APOE results impacts subject recruitment and potential participation in research trials. **Objective:** To investigate if the decision not to disclose genetic risk factor results (APOE) to an individual will impact their willingness to consent to APOE genotyping and their interest in participating in a future research. **Methods:** 100 subjects were enrolled in the pilot study. Each individual participated in a cognitive status interview, a thorough medical record and family history review, and the Mini-Mental State Examination (MMSE). APOE genotyping was performed on consenting individuals using the Spartan Cube® APOE system (Spartan Bioscience, Inc.). Participants were informed that the Spartan Cube APOE system is for research use only (RUO). To determine APOE genotype, 2 buccal samples were collected from each individual using the included swabs and samples were inserted into the test cartridge which contained all necessary reagents for DNA extraction, amplification and fluorescence-based detection of the APOE e2, e3 and e4 alleles. Each individual was swabbed immediately after providing informed consent. During the test's approximately 60-minute runtime, the individual participated in the remaining study procedures, inclusive of the aforementioned medical and family history review, cognitive status interview, and the MMSE. Once the APOE testing had been confirmed to be completed, the subject's participation in the study was complete, without disclosure of the APOE result. **Results:** A total of 100 individuals were enrolled in the study and Table 1 below summarizes the population demographics. Ninety-eight of the 100 enrolled subjects consented to APOE genotyping (98%), despite the participants' understanding that their APOE result would not be disclosed. Of the 98 consenting

individuals, a total of 90 individuals were eligible for APOE genotyping. 26 individuals were APOE e4 carriers (28.9%) and 64 individuals were non-e4 carriers (72.1%). APOE e4 carriers had an average MMSE score of 24.7 compared to an average of 26.0 in non-carriers. An important part of the study was to determine whether subjects would be interested in participating in future research trials without disclosing their APOE genotype. 94% of eligible participants were willing to participate in a future research trial compared to 6% that were not interested. 64% of those interested were willing to participate in MCI/mild AD trials while 34% were willing to participate in healthy aging trials. **Conclusions:** The pilot study results suggest that a high level of subject interest and participation can be achieved without disclosing the results of APOE genotyping. 98% of the study population consented to APOE genotyping with the understanding that they would not receive the result of the test. The pilot study also suggests that despite not knowing their APOE result, individuals were interested in participating in future research trials (94% willing to participate in research trials compared to 6% not interested). This high percentage of willingness to participate in future trials seems to indicate that prior exposure to the clinical research environment positively affects a subject's amenability to future research participation. In addition, subjects received education regarding the informed consent process, clinical research guidelines, and potential research participation opportunities during their study visits. It can be concluded that familiarity with clinical research protocols will advance current and future research participation. It will be important to continue understanding the motivation behind an individual's interest in participation, warranting further research. Expanding this protocol across a network of sites may help to generate a robust research-ready community.

Table 1
Total Study Population Demographics

Study Population Demographics	Count
Total Subjects	100
Minimum Age	62
Maximum Age	85
Average Age	70.11
Number of Males	37
Number of Females	63
Average Education	14.4
Average MMSE score	25.74
Reported Family History	48
Number of APOE e4 carriers	26*
Number of APOE e4 non-carriers	64*

*98 of 100 enrolled individuals consented to APOE genotyping and 90 individuals underwent APOE genotyping

LBP36: MEASUREMENT OF PATHOLOGICAL AMYLOID IN A PATIENT COHORT IN ROUTINE CLINICAL ASSESSMENT: COMPARISON OF VISUAL [18F] FLUTEMETAMOL PET READ AND CSFS MEASURES.

Nenad Bogdanovic¹, Enrico Fantoni², Gill Farrar² ((1) Karolinska Institutet, Stockholm, Sweden and University Hospital Oslo, Oslo University, Norway; (2) GE Healthcare Life Sciences. Amersham, UK and Boston, USA)

Introduction: Amyloid PET imaging and CSF beta-amyloid (Aβ42) measurement are two valid alternatives for determining the presence of pathological amyloid load. The accuracy of measurement by the two diagnostic modalities was previously found by Palmqvist et al., 2015 to be comparable. However, the CSF Aβ42 threshold required to establish a “positive” diagnosis of beta-amyloid plaque accumulation is somewhat arbitrary and varies between sites. This 60-patient cohort from routine clinical assessment compared matched pairs of CSF Aβ42 with [18F]flutemetamol PET read results to assess the concordance between PET and CSF measures. T and P-tau measures were also collected. **Methods:** During the course of 18 months, 58 patients referred by their general practitioner to the Oslo University Memory Clinic with cognitive complaints (mean age 69; range 49 to 81) underwent lumbar CSF fluid sampling and PET scanning following the intravenous injection of approximately 185MBq [18F]flutemetamol. Aβ42, T-tau, and P-tau concentrations were determined in the Norwegian Central CSF Laboratory in Akerhus University Hospital, Oslo using INNOTEST enzyme-linked immunosorbent assays (Fujirebio, Ghent, Belgium). PET [18F]flutemetamol images were read and classified by readers trained per the manufacturers instructions as either positive or negative. **Results:** [18F]Flutemetamol PET scanning resulted in 36 subjects being amyloid-positive and 22 negative. 17/22 negative amyloid scan had Aβ42 measures above 770pg/mL. 15 cases below 550pg/mL had a positive PET read. The remainder of the 26 cases had Aβ42 measures between 560-760 pg/ml with 25/26 reading amyloid positive in the PET read and only 5/26 reading negative. **Conclusion:** Results indicate that a threshold of over 720pg/mL captures approximately 78% of PET negatives whilst below 720pg/mL leads to a PET positivity rate of 89%. This cutoff is higher than regularly accepted in routine practise (550 pg/mL). Seventeen cases out of 58 lie in the range 650-770 pg/mL an area where there is not a consistent pattern of either positive or negative PET scan reads. The results indicate that [18F]flutemetamol PET is a key contributor in the diagnostic decision-making process in 54/58 cases, whereas CSF amyloid was useful in 34/58 cases or 49/58 when a the threshold of detection of CSF amyloid was adjusted with reference to [18F]flutemetamol PET outcomes. The study indicates that knowledge of the amyloid status can be fundamental as a tool to assign accurate diagnoses. CSF amyloid has similarly high diagnostic utility to amyloid PET only when the CSF threshold of detection is altered to capture early pathological signs of amyloid accumulation. Reference: Palmquist S et al. Detailed comparison of amyloid PET and CSF biomarkers for identifying early Alzheimers Disease. *Neurology* (2015) 85: 1-10

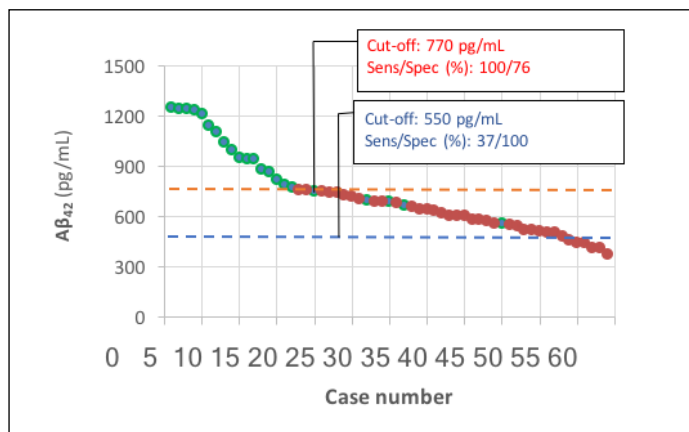

LBP37: KINETIC MEASUREMENT OF NEWLY GENERATED BACE1-CLEAVED APP IN THE HUMAN CENTRAL NERVOUS SYSTEM IN ALZHEIMER'S DISEASE: A PILOT STUDY. Robert J. Vassar¹, Randall J. Bateman², Bruce W. Patterson³, Justyna A. Dobrowolska Zakaria¹ ((1) Department of Neurology, Northwestern University, Feinberg School of Medicine, Chicago, IL, USA; (2) Department of Neurology, Washington University in St. Louis, St. Louis, MO, USA; (3) Department of Medicine, Washington University in St. Louis, St. Louis, MO, USA)

Background: According to the amyloid hypothesis increased production and/or decreased clearance of amyloid-beta ($A\beta$) leads to higher order amyloid structures that initiate a cascade of events, culminating in neuronal death that manifests as Alzheimer's disease (AD). Sequential cleavage of Amyloid Precursor Protein (APP) generates $A\beta$. APP may be processed in one of at least two pathways, initially being cleaved by either α - or β -secretase (BACE1). α -secretase cleavage of APP precludes $A\beta$ formation and produces soluble APP- α (sAPP α). Alternatively, BACE1 cleavage of APP releases soluble APP- β (sAPP β) and subsequent cleavage by γ -secretase produces $A\beta$. Therefore, while sAPP β is a direct product of BACE1 cleavage of APP, $A\beta$ is an indirect product of BACE1 processing that also requires γ -secretase activity. Nevertheless, BACE1 processing of APP is an obligate initial step in $A\beta$ production, and sAPP β is a surrogate marker of BACE1 activity. In some studies BACE1 and sAPP β are increased in cerebrospinal fluid (CSF) and post-mortem AD brain. Our previous data demonstrate an increase in CSF sAPP β :sAPP α ratio in AD subjects versus controls, indicating a pathophysiological shift toward BACE1 processing of APP. Further, sAPP β and $A\beta$ concentrations are highly positively correlated in human CSF, but sAPP α and $A\beta$ correlate less well, which suggests BACE1 activity mediates both sAPP β and $A\beta$ differences among people. In brains of postmortem AD and amyloid mouse models, we have shown that BACE1 levels are dramatically increased in dystrophic neurites surrounding amyloid plaques, which exhibit increased BACE1 cleavage of APP and the generation of both sAPP β and $A\beta$. Recently it was shown that CSF $A\beta$ 38 and $A\beta$ 40, as surrogate markers of $A\beta$ production, were elevated in humans with amyloid deposition and the correlation between these metabolites and amyloid load was most pronounced in subjects negative for ApoE4. Together these findings suggest increased BACE1 activity may cause increased $A\beta$ in an AD subpopulation, but has not been directly assessed until now. **Methods:** Using highly sensitive stable isotope labeling kinetics (SILK)/immunoprecipitation (IP)/liquid chromatography-tandem mass spectrometry (LC-

MS/MS) methods, we quantified sAPP β and sAPP α in CSF from human AD subjects and controls to determine β - and α -secretase activity in human CNS. In this pilot study, newly generated sAPP β and sAPP α were measured in eleven elderly human subjects who had undergone [¹³C6]leucine labeling and hourly CSF collection over 36 hours. Three subjects had brain amyloidosis (Amyloid+); eight were free of amyloid (Amyloid-). Serially-sampled CSF underwent sequential IP to isolate sAPP β (using a neo-epitope sAPP β -specific-antibody-bead complex) and then sAPP α (using a W02-antibody-bead complex). Peptides resulting from tryptic digest of the purified sAPP β or sAPP α were quantified by LC-MS/MS using the Dionex UltiMate 3000/TSQ Quantum Ultra system. To determine kinetic behavior of APP metabolites, the fraction of the metabolite derived from de novo synthesis was measured by calculating hourly sAPP β and sAPP α mole fraction labeled (MFL), normalized to plasma leucine enrichment, over 36 hours. In order to determine each subject's newly generated APP metabolites by absolute quantitation, normalized sAPP β or sAPP α MFL was multiplied by the absolute concentration of sAPP β or sAPP α , respectively. Absolute concentrations were previously determined by sAPP β and sAPP α specific ELISAs. Regression analyses were performed to determine the extent of the relationship between newly generated metabolites and brain amyloid load (determined by PET PiB). **Results:** Both sAPP β and sAPP α turnover rates were slower in Amyloid+ subjects. There was a slight upslope of the ratio of newly generated sAPP β :sAPP α in Amyloid+ subjects (slope, $m=0.019$) which was significantly higher than Amyloid- ($m=0.01$; $p=0.013$); both slopes were significantly non-zero ($p<0.0001$). This indicates that sAPP β turnover rate is marginally slower than sAPP α , and this difference is accentuated in the setting of amyloid deposition. Newly generated sAPP β , as well as the absolute ratio of newly generated sAPP β :sAPP α , were significantly elevated in Amyloid+ subjects ($p<0.0001$). In contrast, newly generated sAPP α was not significantly different between groups. Brain amyloid load is positively correlated to sAPP β ($p=0.03$) when normalized to sAPP α (due to high inter-subject APP level variability). Normalized $A\beta$ 40 and $A\beta$ 38 trend to being significantly positively correlated to brain amyloid load. Importantly, these results strongly suggest increased processing of APP by BACE1 in the subjects with brain amyloid deposition. **Conclusion:** This pilot study will be further expanded. We hypothesize that most AD patients overproduce $A\beta$ due to increased BACE1 activity as measured by increased production of sAPP β . Direct measurement of kinetics and newly generated sAPP β in vivo will determine if, and by how much, BACE1 activity is increased in AD subjects. Results would allow for characterization of AD subpopulations most likely to benefit from BACE1 inhibitors. Outcomes will elucidate human CNS APP physiology and AD pathophysiology and also prove useful for measuring pharmacodynamic effects of candidate therapeutics. BACE1 is currently a high priority target for AD, thus results of altered BACE1 activity in AD are critical for understanding AD pathophysiology and development of disease modifying therapeutics.

LBP38: RELIABILITY OF A RAPID APOE ASSAY FOR ALZHEIMER'S RISK ASSESSMENT AND CLINICAL TRIAL SCREENING. Athene Lee^{1,2}, William Menard², Gina Tonini², Louisa Thompson^{1,2}, Jessica Alber^{1,2}, Stephen Salloway^{1,2} ((1) Warren Alpert Medical School of Brown University, Providence, RI, USA; (2) Butler Hospital, Providence, RI, USA)

Background: High screen fail rate on amyloid PET in Alzheimer's disease (AD) prevention trials is cost prohibitive and delays the discovery of effective therapeutics. Apolipoprotein (APOE) $\epsilon 4$ carriers are at higher risk for AD and tend to accumulate brain amyloid at an earlier age. Pilot data from the Butler Alzheimer's Prevention Registry shows a reduction in screen fail rate from 81% to 57% by enriching trials with $\epsilon 4$ carriers. This finding supports the use of APOE genotyping to screen potential participants in our registry; however, typical Clinical Laboratory Improvement Amendment (CLIA) certified laboratory testing requires batch processing and has a turnaround time of at least 1-2 weeks. The Spartan Cube APOE system (Spartan Bioscience, Inc.) is a rapid, on-site APOE genotyping analysis method that may potentially improve screening efficiency, yet the reliability of this method is not well established. **Objectives:** This study examines the reliability of a new on-site APOE genotyping analysis method (Spartan Cube APOE system) and evaluates the potential application in our registry to expedite screening and enrich AD prevention trials with high risk individuals. **Methods:** Seventy one older adults with known APOE genotype from the Butler Alzheimer Prevention Registry consented to this reliability study. All participants had already received their CLIA certified APOE genotyping results from a trained clinician through an APOE disclosure study. The CLIA results were based on buccal swab samples and analyzed in two laboratories. Fifty six samples were processed with a polymerase chain reaction (PCR) Taqman assay, and fifteen were processed with a PCR amplified bi-directional Sanger di-deoxy sequencing. A second buccal swab was conducted to determine the reliability of the Spartan Cube APOE system (Cube). The participants were informed that the Cube is for research use only and that they would not receive their results from this reliability study. The Cube is a portable device connected to a laptop that provides step-by-step on-screen instructions to run the test and displays the APOE genotype upon test completion. To determine APOE genotype, two buccal samples were collected from each individual by trained Butler staff. The samples were then inserted into the APOE test cartridge which contained all necessary reagents for DNA extraction, PCR amplification, and fluorescence-based detection of the APOE $\epsilon 2$, $\epsilon 3$ and $\epsilon 4$ alleles. The samples were run either immediately or up to 72 hours after collection, and the reaction took approximately 60 minutes to complete. Intraclass Correlation Coefficient (ICC) estimate and its 95% confident intervals were calculated using SPSS statistical package version 21 (SPSS Inc., Chicago, IL) based on a single-rating, absolute-agreement, 2-way randomized-effects model. **Results:** Participants had a mean age of 66.9 (range: 60 - 77) and 16.8 years of education on average (range: 12 - 22). 65% were females and 98% were Caucasians. None of the participants had a prior cognitive diagnosis. Mini-mental status examination scores ranged from 27 to 30. Based on the CLIA certified APOE genotyping, 32% of the 71 participants were $\epsilon 4$ carriers. Specifically, there were 6 $\epsilon 2/\epsilon 3$, 42 $\epsilon 3/\epsilon 3$, and 23 $\epsilon 3/\epsilon 4$. Using the Cube APOE system, 70 samples were successfully run (one sample yielded no result and will be repeated). Out of the

70 pairs of APOE results, there was 100% concordance between the CLIA certified laboratory and the Cube. ICC estimate for the entire sample (n = 71) was 0.95, with 95% confidence intervals of 0.91 - 0.97. **Conclusion:** The results indicate that the Spartan Cube APOE system has excellent reliability when compared to the CLIA certified gold standard. While clinical disclosure of APOE genotype should still require confirmation from a CLIA certified laboratory, this new portable device provides clinicians and researchers an alternative way to rapidly identify $\epsilon 4$ carriers for AD prevention trials. In the case of a registry with a long wait time to trial screen, rapid APOE genotyping can help prioritize individuals with higher risk which may reduce screen fail rates. At the clinic level, clinicians may use rapid APOE genotyping to complement consultation results and to triage patients to appropriate trials. References: a Alber J., Collier M., Goldfarb D., Thompson L., Dawson B., Salloway S., & Lee A. (2018). Safety, Tolerability, and Lifestyle Changes Associated with APOE Disclosure in the Butler Alzheimer's Prevention Registry: Implications for Recruitment to Clinical Trials. Abstract presented at Alzheimer's Association International Conference, Chicago, IL, USA.

LBP39: CEREBROSPINAL FLUID PROFILING OF MULTIPLE PATHOPHYSIOLOGICAL PATHWAYS IN ALZHEIMER'S DISEASE. Steven Arnold¹, Bianca A. Trombetta², Becky C. Carlyle² ((1) Massachusetts General Hospital and Harvard Medical School; (2) Department of Neurology, Massachusetts General Hospital, Harvard Medical School, Boston, MA)

Background: Alzheimer's disease (AD) is a complex neurodegenerative disease driven by multiple interacting pathophysiological processes that ultimately result in synaptic loss, neuronal death, and dementia. Along with amyloid- α and tau pathologies, other major causes and consequences of neurodegeneration include inflammation/immune modulation, metabolic dysfunction, oxidative stress and vascular injury. Differing contributions of these diverse pathways may reflect the molecular heterogeneity of AD subgroups and individuals. **Objectives:** 1) To qualify a cerebrospinal fluid multi-pathophysiology panel (CMP3) encompassing a broad selection of commercially available immunoassays; 2) To evaluate the biotemporal stability of protein levels across six pathophysiological domains of interest in AD, including core amyloid- β (A β 42) and tau AD biomarkers, neurodegeneration, inflammation/immune modulation, metabolism, oxidative stress and neurovascular injury; and 3) To evaluate the heterogeneity of CMP3 profiles in AD and non-neurodegenerative disease controls. **Methods:** Paired baseline and eight-week CSFs from 20 participants in a clinical drug trial for MCI/AD were used to evaluate sensitivity, intra-assay precision, inter-assay replicability, and eight-week biotemporal stability of analytes measured with commercially available single- and multi-plex ELISA assays. Coefficients of variation (CV), intraclass correlation and Wilcoxon signed rank tests were applied to select thirty-two high performing analytes comprised the CMP3. This was then applied to 85 AD and control CSFs. Multivariate models (cluster, regression, Bayesian model ranking) were applied to detect disease discriminators and categorize heterogeneous disease subtypes by CMP3 profiles. **Results:** Best performing assays by domain included: 1) Classical AD biomarkers A β 42, total tau and phospho-tau (pT181); 2) Neurodegeneration markers FABP3 and NfL;

3) Inflammation/immunomodulation markers IL6, IL7, IL8, IL12_23p40, IL15, IL16, MCP1, MDC, MIP1B and YKL40, 4) metabolic markers adiponectin, soluble insulin receptor and 24-hydroxycholesterol, 5) oxidative stress marker 8-OHdG, and 6) vascular injury markers Flt1, ICAM1, MMP2, MMP10, PIGF, VCAM1, VEGF and VEGFD. Overall, CMP3 provided >90% discrimination of AD from controls. Significant heterogeneity of profiles was observed in AD with pathophysiological domain-predominant subtypes identified. **Conclusions:** CSF molecular profile subtypes in AD may reflect the heterogeneity of pathophysiological contributions driving neurodegeneration and dementia. Recognition of these profiles may help guide selection of therapeutic interventions at the individual level and allow biomarker tracking of target engagement and pathophysiological response.

LBP40: INTERIM BIOMARKER ANALYSES OF PHASE II STUDY DATA ON SAFETY AND EFFICACY OF GM-CSF IN MILD-TO-MODERATE ALZHEIMER'S DISEASE.

Timothy D. Boyd^{1,2}, Jonathan Woodcock^{1,3}, Stefan Sillau^{1,3}, Vanessa Adame^{1,2}, Thomas Borges^{1,4}, Ashesh Thaker^{1,4}, Brianne Bettcher^{1,5}, Joseph Daniels^{1,3}, Kate Heffernan¹, Huntington Potter^{1,2,3} (1) Rocky Mountain Alzheimer's Disease Center, University of Colorado Anschutz Medical Campus, Aurora, CO, USA; (2) Linda Crnic Institute for Down Syndrome, University of Colorado Anschutz Medical Campus, Aurora, CO, USA; (3) Department of Neurology, University of Colorado at Anschutz Medical Campus, Aurora, CO, USA; (4) Department of Radiology, University of Colorado at Anschutz Medical Campus, Aurora, CO, USA; (5) Department of Neurosurgery, University of Colorado at Anschutz Medical Campus, Aurora, CO, USA)

Background: Epidemiological studies have shown that the majority of rheumatoid arthritis (RA) patients do not develop Alzheimer's disease (AD), and this effect was originally proposed to be due to the use of non steroidal anti-inflammatory drugs (NSAIDs) by RA patients. However, large clinical trials showed that NSAIDs were unsuccessful — and potentially detrimental — in treating subjects with mild cognitive impairment (MCI) or AD. Based on these findings, we proposed and tested our novel hypothesis that intrinsic factors involved in RA pathogenesis itself may underlie the protective effects of RA against AD. We focused on the myeloid lineage phagocytes that are up-regulated in RA, and in particular on their associated increase in hematopoietic colony-stimulating factors. We identified granulocyte-macrophage colony-stimulating factor (GM-CSF) as one such factor upregulated in RA that may protect against AD. In experiments to test our hypothesis, we found that 20 daily subcutaneous (SC) injections of GM-CSF in transgenic AD mice reduced their cerebral amyloid levels by greater than 50% and completely reversed their cognitive impairment (Boyd et al., 2010). We subsequently found that treatment of cancer patients undergoing autologous hematopoietic cell transplant (HCT) with recombinant human GM-CSF (rhGM-CSF/sargramostim) as part of routine supportive care was associated with a significant improvement in cognitive functioning at 6 and 12 months relative to baseline before the HCT procedure (Jim et al., 2012). **Objectives:** This clinical trial (NCT01409915) was initiated to determine whether rhGM-CSF/sargramostim can safely halt or reduce cognitive decline and brain pathology in subjects with mild-to-moderate AD and to study associated biomarker changes. **Methods:** We are conducting a randomized placebo-controlled double-

blind Phase II safety and efficacy trial of sargramostim in mild-to-moderate AD subjects, with sargramostim given at 250 $\mu\text{g}/\text{m}^2/\text{day}$ SC for 5 days/week for three consecutive weeks and with 45 and 90 days post-treatment follow-up visits. Neurological and neuropsychological assessments, MRI imaging, and blood biomarker electrochemiluminescence (ECL) analyses are performed to assess the safety and effects of treatment. Amyloid-PET neuroimaging was added midway through the trial as inclusion criteria, with baseline and first follow-up visit scans compared to identify potential effects on amyloid load. **Results:** Interim analyses of 15 sargramostim-treated and 15 placebo-treated subjects has revealed no drug-related serious adverse events, including no incidence of amyloid-related imaging abnormalities (ARIA). When comparing neuropsychological measures at the end of treatment to baseline, mean changes of the MMSE score showed improvement in the sargramostim group relative to baseline ($p=0.0029$) and to the placebo group ($p=0.0175$) by repeated measures mixed model analysis. Differences were not significant at follow-up visits. Amyloid PET data for the last 10 subjects also showed a significant reduction in amyloid in the sargramostim-treated group at the first follow-up visit compared to baseline. When comparing fold differences from end of treatment to baseline, interim ECL analyses of 62 blood biomarker analytes showed significant changes in levels of several cytokines and chemokines, which correlate with sargramostim treatment and with neuropsychological score changes. However, these biomarkers were not significantly changed from baseline levels at the follow-up visits. **Conclusions:** Although preliminary and based on a small number of subjects, the safety and neuropsychological results warrant completing this three-week trial and initiating our planned Alzheimer's Association "Part the Cloud"-funded 24-week treatment Phase II-III trial of rhGM-CSF/sargramostim in subjects with mild-to-moderate AD. Furthermore, the observed blood biomarker changes support additional analyses with more subjects from this trial and with subjects enrolled in the 24-week trial, as well as comparison between blood biomarkers and cerebral spinal fluid (CSF) biomarkers from the 24-week trial, and investigation into whether any sargramostim-associated changes in blood and CSF biomarker levels also correlate with changes in AD amyloid load and other pathophysiology. References: Boyd, T., S. Bennett, T. Mori, N. Governatori, M. Runfeldt, M. Norden, J. Padmanabhan, P. Neame, I. Wefes, J. Sanchez-Ramos, G. Arendash, and H. Potter (2010). «GM-CSF upregulated in rheumatoid arthritis reverses cognitive impairment and amyloidosis in Alzheimer mice.» *J Alzheimers Dis* 21(2): 507-518. Jim, H., T. Boyd, M. Booth-Jones, J. Pidala, and H. Potter (2012). «Granulocyte Macrophage Colony Stimulating Factor Treatment is Associated with Improved Cognition in Cancer Patients.» *Brain Disord Ther* 1(1).

Theme: Clinical trials: Cognitive and functional endpoints

LBP41: EFFECTS OF 2-YEAR WALNUT SUPPLEMENTATION ON COGNITIVE DECLINE IN HEALTHY ELDERLS: THE WALNUTS AND HEALTHY AGING (WAHA) STUDY. Nina Coll-Padrós¹, Aleix Sala-Vila^{2,3}, Cinta Valls-Pedret², Mercè Serra-Mir^{2,3}, Montserrat Cofán^{2,3}, Irene Roth², Tania Freitas-Simoes², Mónica Doménech², Lúcia Vaqué-Alcázar⁴, David Bartrés-Faz⁴, Sujatha Rajaram⁵, Joan Sabatés⁵, Emilio Ros^{2,3} ((1) *Alzheimer Disease and Other Cognitive Disorders Unit, Neurology Service, Hospital Clínic and Institut d'Investigacions Biomèdiques August Pi i Sunyer (IDIBAPS), Barcelona, Spain;* (2) *Lipid Clinic, Endocrinology and Nutrition Service, Hospital Clínic, Barcelona, Spain;* (3) *CIBER Fisiopatología de la Obesidad y Nutrición (CIBEROBN), Instituto de Salud Carlos III (ISCIII), Spain;* (4) *Institut de Neurociències i Facultat de Medicina i Ciències de la Salut, Universitat de Barcelona, Barcelona Spain;* (5) *School of Public Health, Loma Linda University, Loma Linda, CA, U.S.A.*)

Background: Nuts are reputed as cardioprotective foods. Walnuts in particular are rich in polyphenols and polyunsaturated fatty acids (PUFAs), including alpha-linolenic acid, the vegetable omega-3 fatty acid. Previous research on brain PUFAs metabolism identified several mechanisms regulated by PUFAs and their role in neuronal survival, synaptic function and the regulation of brain inflammation. While there is sufficient rationale for the role of walnuts in neuroprotection, direct clinical evidence is lacking. The Walnuts and Healthy Aging (WAHA) study* is the first RCT assessing cognitive function in an elderly cohort following daily ingestion of walnuts for 2 years. As brain oxidative stress and inflammation are believed to underlie cognitive deterioration and dementia, we hypothesized that beneficial nutrients in walnuts would counteract age-related cognitive decline after long-term consumption. **Methods:** WAHA is a 2-site (Barcelona and Loma Linda, California) 2-year, randomized feeding study assessing the effects of walnuts on age-related diseases. We assigned 708 cognitively healthy, free-living elders (63-79 years, 68% women) to a diet enriched with walnuts (WG) at 15% of energy or a control diet with abstention of nuts (CG) in a 1:1 ratio. Every 2 months throughout the trial participants attended clinic visits with a dietitian. At baseline and 2 years a nutritionist evaluated nutrient intake from food records and a trained neuropsychologist administered a comprehensive battery of cognitive tests assessing memory, language, perception, and executive function. Moreover, in the Barcelona site 119 participants underwent repeated structural and functional brain magnetic resonance imaging (MRI) with a Siemens 4-T apparatus. We created composite cognitive measures by converting the individual test results to Z scores and computing the average scores within each cognitive domain: memory, frontal, language, praxis, perception and global cognition (includes all domain composite scores). The primary outcome was the mean change from baseline in the global cognition composite. In a covariance model, data were adjusted for vascular and dementia risk factors, including sex, age, years of education, APOE4 genotype, smoking, body mass index, physical activity, diabetes, hyperlipidaemia, hypertension, depression score and study site. **Results:** The trial was completed by 90% of participants. Compliance with walnut ingestion was >98%. Covariates were similar at

baseline in the 2 intervention groups, as well as in the 2 sites, except for educational level (mean 5 years more education at Loma Linda). Nutrient intake was also dissimilar between the 2 sites, reflecting customary dietary practices in Barcelona (Mediterranean diet) and Loma Linda (healthy American diet). At 2 years, no significant between-group differences in cognition were detected. Adjusted changes (means, 95% CI) in the global cognition composite score were -0.056 (-0.085 to -0.028) in WG and -0.083 (-0.111 to -0.054) in CG (p=0.209). Post-hoc analyses revealed significant differences between the groups at 2 years only at the Barcelona site, wherein adjusted changes in the global cognition score were -0.032 (-0.072 to 0.008) in WG and -0.102 (-0.143 to -0.062) in CG (P=0.016). Among cognitive domains, only the perception score improved significantly in WG compared to CG (p=0.005). Brain MRI findings showed similar rates of grey matter loss (measured by cortical thickness) with time for the two groups. Results of functional MRI at 2 years showed that participants in the CG recruited a larger extent of functional networks during a cognitively demanding working memory task compared to WG to achieve the same level of performance, indicating greater cognitive effort. **Conclusion:** Walnut supplementation for 2 years did not delay cognitive decline in an older population at risk of age-related diseases but cognitively healthy at baseline. However, functional brain MRI in a subset and post-hoc analyses by site suggest that regular walnut consumption might positively influence cognitive performance and thus counteract age-related cognitive decline. The fact that participants from the Barcelona site were less educated than those from the Loma Linda center might explain in part why the walnut intervention was beneficial for cognition only in the former. The present results are encouraging but not conclusive for an effect of walnuts on brain health and further investigation is warranted. * ClinicalTrials.gov identifier NCT01634841

LBP42: ADCOMS: A POST-HOC ANALYSIS USING DATA FROM THE LIPIDIET TRIAL IN PRODROMAL ALZHEIMER'S DISEASE. Suzanne B. Hendrix¹, Hilka Soininen^{2,3}, Pieter Jelle Visser^{4,5}, Alina Solomon^{2,6,7}, Miia Kivipelto^{2,6,7}, Tobias Hartmann^{8,9} on behalf of the LipiDiDiet clinical study group ((1) *Pentara Corporation, Salt Lake City, UT, USA;* (2) *Department of Neurology, Institute of Clinical Medicine, University of Eastern Finland and Kuopio University Hospital, Kuopio, Finland;* (3) *Neurocenter, Department of Neurology, Kuopio University Hospital, Kuopio, Finland;* (4) *Department of Psychiatry and Neuropsychology, Alzheimer Center Limburg, University of Maastricht, Maastricht, the Netherlands;* (5) *Department of Neurology, Alzheimer Center, VU University Medical Center, Amsterdam, the Netherlands;* (6) *Department of Clinical Geriatrics, NVS, Karolinska Institutet, Huddinge, Sweden;* (7) *Clinical Trials Unit, Department of Geriatric Medicine, Karolinska University Hospital, 14152 Huddinge, Sweden;* (8) *Deutsches Institut für Demenz Prävention (DIDP), Medical Faculty, Saarland University, Homburg, Germany;* (9) *Department of Experimental Neurology, Saarland University, Homburg, Germany*)

Background: The LipiDiDiet study was designed to investigate the effects of the multinutrient combination Fortasyn Connect over 24 months in prodromal Alzheimer's disease (AD). Main results were published in Soininen et al., *Lancet Neurology* 2017.1 The LipiDiDiet study was initiated shortly after the first definition for prodromal AD was finalized by Dubois et al (2007),² and as such is one of the

first randomized clinical trials (RCTs) in this population using these criteria. Evaluating efficacy of therapeutic interventions for mildly affected populations with only limited cognitive and functional decline and subtle impairment depends on sufficiently sensitive and informative composite outcome measures. Clinical Dementia Rating - Sum of Boxes (CDR-SB) has been proposed as such a measure.³ More recently, the AD Composite Score (ADCOMS) was developed as a broader composite clinical outcome measure for trials in prodromal and mild AD dementia.⁴ It consists of cognitive and functional items from three commonly used scales in AD dementia trials: the Alzheimer's Disease Assessment Scale-cognitive subscale (ADAS-cog), Mini-Mental State Examination (MMSE), and CDR-SB. The combination of selected items from these scales was shown to have the highest sensitivity for measuring changes and treatment effects over time in early AD subjects as compared to the individual scales.⁴ In 2018, for the first time, results were presented from an RCT using ADCOMS as the primary outcome.⁵ Results were interpreted as supporting the applicability of this composite score. However, more studies are needed to establish general applicability across different trial settings and the contribution of the different subdomains to the composite. **Objectives:** The main aim of the present post-hoc analysis was to explore the effects of a multinutrient intervention on cognition and global function, as captured by ADCOMS and its subdomains, using data from the LipiDiDiet trial. Additionally, evaluating ADCOMS in a second, independent, early AD population provides broader knowledge of the utility of ADCOMS as a single clinical outcome measure in early AD trials. **Methods:** The LipiDiDiet study (NTR1705) was a 24-month, double-blind, parallel-group, multi-center RCT (11 sites in Finland, Germany, the Netherlands, and Sweden), with optional 12-month double-blind extensions. A total of 311 participants with prodromal AD, defined according to the International Working Group (IWG)-1 criteria,² were enrolled. Participants were randomly assigned (1:1) to active product (125 mL drink containing the multinutrient combination Fortasyn Connect) or iso-caloric control product once daily. Primary outcome was the change in a cognitive function composite z-score based on five items of a neuropsychological test battery (NTB). Secondary outcomes included CDR-SB, whereas the ADAS-cog-13 and MMSE were included as exploratory parameters. ADCOMS was calculated using the selected items and corresponding partial least squares coefficients.⁴ Score ranges from 0.0 to a maximum of 1.97, with increased values indicating worse performance. Contribution of the separate (ADAS-cog, MMSE, and CDR-SB) subdomains to the total score was explored by calculating the separate domains based on the same items and coefficients. Statistical analyses were performed using a linear mixed model for repeated measures in a modified intention-to-treat population.¹ **Results:** Scores on ADCOMS in this prodromal AD population at baseline were 0.258 (standard deviation [SD] 0.143, n=138) in the active group and 0.247 (SD 0.140, n=140) in the control group. During the 24 months intervention, worsening on ADCOMS was 36% less in the active group than in the control group. Estimated mean change from baseline (standard error) was 0.085 (0.018) in the active group and 0.133 (0.018) in the control group; estimated mean treatment difference was -0.048 (95% CI -0.090 to -0.007; p=0.023). Changes were mainly driven by the contribution of the 6-item CDR-SB subdomain (estimated mean change from baseline [standard error]: 0.065 [0.016] in the active group and 0.099 [0.016] in the control group, p=0.033), and to a lesser extent by the 2-item

MMSE subdomain (0.007 [0.005] in the active group and 0.019 [0.005] in the control group, p=0.065). No differences between groups were observed for the 4-item ADAS-cog subdomain.

Conclusions: In this post-hoc analysis of the LipiDiDiet study data, the active group showed significantly less clinical decline over 24 months as measured by ADCOMS, suggesting that the specific multinutrient intervention has beneficial effects on cognition and global function in a prodromal AD population. These analyses further contribute to the validation of ADCOMS in early AD and suggest applicability and sensitivity across different intervention strategies in the earliest stages of AD. **References:** 1. Soininen, H., et al. *Lancet Neurol*, 2017; 16(965-75). 2. Dubois, B., et al. *Lancet Neurol*, 2007; 6(734-46). 3. U.S. Department of Health and Human Services Food and Drug Administration Center for Drug Evaluation and Research. *Guidance for Industry, Alzheimer's Disease: Developing Drugs for the Treatment of Early Stage Disease*, Draft guidance. 2013. 4. Wang, J., et al. *J Neurol, Neurosurg & Psych*, 2016; 87(993-9). 5. Swanson, C.J., et al. Abstract; AAIC 2018.

LBP43: INTRAVENTRICULAR INJECTION OF HUMAN UMBILICAL CORD BLOOD MESENCHYMAL STEM CELLS IN PATIENTS WITH ALZHEIMER'S DISEASE DEMENTIA: A PHASE I CLINICAL TRIAL. Hee Jin Kim^{1,2}, Kyung Rae Cho^{2,3}, Hyemin Jang^{1,2}, Jung Il Lee^{2,3}, Seongbeom Park^{1,2}, Soo Jin Choi⁴, Sung Tae Kim⁵, Seung Hwan Moon⁶, Kyung-Han Lee⁶, Sang Won Seo^{1,2,7}, Duk L. Na^{1,2,8} ((1) *Departments of Neurology*; (3) *Neurosurgery*; (5) *Radiology*; (6) *Nuclear Medicine Samsung Medical Center, Sungkyunkwan University School of Medicine, Seoul, Korea*; (2) *Neuroscience Center, Samsung Medical Center, Seoul, Korea*; (4) *Biomedical Research Institute, MEDIPOST Co., Ltd, Seoul, Korea*; (7) *Department of Clinical Research Design & Evaluation, SAIHST, Sungkyunkwan University, Seoul, Korea*; (8) *Department of Health Sciences and Technology, SAIHST, Sungkyunkwan University, Seoul, Korea*)

Background: Alzheimer's disease is the most common cause of dementia and currently there is no disease modifying treatment. Animal studies showed that mesenchymal stem cells (MSCs) reduce the amount of amyloid plaque in the brain and result in favorable functional outcome. **Objectives:** We conducted a phase I clinical trial in nine patients with mild to moderate Alzheimer's disease to evaluate the safety and dose-limiting toxicity of repeated intraventricular injection of human umbilical cord blood derived MSCs (hUCB-MSCs) via Ommaya reservoir. **Methods:** We recruited nine mild to moderate Alzheimer's disease dementia patients from Samsung Medical Center, Seoul, Korea. The patients underwent surgery for Ommaya reservoir insertion under local anesthesia. 4 weeks after the surgery, three patients received low dose (1.0 x 10⁷ cells/2ml) and six patients received high dose (3.0 x 10⁷ cells/2ml) of hUCB-MSCs into right lateral ventricle for 3 times with 4 weeks interval. The patients were followed up for 16 weeks after the third hUCB-MSC injection. **Results:** No patient showed serious adverse events during the 28 weeks of study period. Within 24 hours after Ommaya reservoir insertion, four patients experienced wound pain and one patient experienced headache. After hUCB-MSC injection, the most common adverse event was fever (n=9) followed by headache (n=7), nausea (n=5), and vomiting (n=4), which all subsided within 36 hours. There was no dose limiting toxicity. **Conclusions:** Administration of hUCB-MSCs into the lateral ventricle by Ommaya reservoir was feasible, safe, and well-tolerated. Further randomized control

trials are warranted to test the efficacy. (ClinicalTrials.gov Identifier: NCT02054208)

LBP44: EXPLORATORY ANALYSIS OF RESULTS FROM THE NILVAD TRIAL SUGGEST BENEFIT IN VERY MILD AD SUBJECTS. Michael Mullan^{1,2}, Laila Abdullah², Heather Langlois², Fiona Crawford^{1,2}, Anders Wallin³, Suzanne Hendrix⁴, Kaj Blennow⁵, Brian Lawlor⁶ The NILVAD consortium ((1) Archer Pharmaceuticals, Sarasota, FL, USA; (2) Roskamp Institute, Sarasota, FL, USA; (3) Department of Psychiatry and Neurochemistry, Institute of Neuroscience and Physiology, Sahlgrenska Academy, University of Gothenburg, Sweden; (4) Pentara Corporation, Salt Lake City, UT, USA; (5) Clinical Neurochemistry Laboratory, Sahlgrenska University Hospital/Mölndal, Mölndal, Sweden; (6) Trinity College Dublin, Dublin, Ireland)

Background: NILVAD was an investigator driven phase III clinical trial of the repurposed anti-hypertensive dihydropyridine nilvadipine in mild to moderate Alzheimer's disease (AD). The pre-specified primary analyses failed to show any treatment benefits for nilvadipine in the total population of mild to moderate AD patients. We explored whether the effects of nilvadipine on cognition in the NILVAD trial were influenced by baseline Alzheimer's disease (AD) severity. **Methods:** 511 subjects with mild to moderate AD were recruited across 23 sites in 9 different European countries. Subjects received 8 mg over encapsulated nilvadipine or matching placebo over a period of 18 months. The sponsor of the trial was St. James's Hospital, Dublin. Academic trial units were used to monitor the trial in each country. The primary outcome measures were the Alzheimer's Disease Assessment Scale Cognitive (ADAS-Cog) and the Clinical Dementia Rating Scale sum of boxes (CDR-sb) and the Disability assessment for Dementia (DAD) was a secondary outcome measure. The secondary analysis included examination of subgroups by baseline MMSE scores. CSF samples were collected by lumbar puncture and were available for 94 participants at baseline, and 55 of these subjects at treatment termination (78 weeks). Levels of A β 38, A β 40, and A β 42 were quantified using the Meso-scale discovery (MSD) platform and levels of total tau and phosphorylated tau (P181) were measured by sandwich ELISA (Innotest; Fujirebio). **Results:** In the NILVAD trial, nilvadipine was well tolerated with the only adverse event occurring more frequently on nilvadipine than placebo being peripheral edema. CSF analyses of a subset of participants indicated that 91% met CSF biomarker criteria for AD. Changes in CSF levels of amyloid and tau were consistent with levels of cognitive decline and showed differential modulation in response to nilvadipine treatment Stratification of the total study population by the baseline MMSE scores showed that individuals with higher baseline MMSE scores (25+) who were treated with nilvadipine showed 47% less decline on ADAS-Cog scores after 78-weeks compared to placebo treated individuals. An examination of the different cognitive traits from the ADAS-Cog 12 sub-scales showed nilvadipine to have beneficial effects on the memory trait in the very mild AD group (25+) and beneficial effects on the language trait in the mild AD group (20-24). **Conclusion:** These subgroup analyses suggest that nilvadipine may have cognitive benefits for individuals in the earliest (and potentially, preclinical) stages of AD. Further studies focused on such individuals are required to confirm these findings.

LBP45: CAN DIGITAL FOOTPRINTS CAPTURE CLINICALLY RELEVANT GAIT ENDPOINTS IN NON-CLINICALLY SETTING: A PROOF OF CONCEPT? Marie Mc Carthy¹, Crystal Gon² ((1) ICON PLC, Dublin, Ireland; (2) Trinity College Dublin, Ireland)

Background: This proof of concept has two components; mining the literature to identify the gait parameters that correlate with cognitive decline and determining if those endpoints could be captured using smart-insoles. There is growing interest in gait change as a marker for cognitive decline, with reports of gait disturbances found to precede dementia by more than 5 years. The use of wrist worn physical activity monitors (PAM) to collect steps and gait cadence is well established. While gait speed has been identified as signal, other spatiotemporal characteristics also appear have potential as key indicators of cognitive decline. Assessing spatiotemporal gait is not a simple process with the use of electronic walkways and specialist clinics common. This can impact the number of locations available for gait assessments particularly in clinical trials. New technology such as smart-insoles is emerging. This has the potential to capture more nuanced assessment of gait change including balance, inter-gait variability even stance. If alternative viable technologies were available gait could be assessed outside of specialist clinics, including residential care setting or the patient's own home. **Method:** A literature review was carried out in PubMed using the search terms "Gait" "Cognitive Decline" and "Alzheimer's Disease" to identify the gait parameters that have been associated with cognitive decline. 68 relevant publications were identified from which gait speed, stride time variability and balance were found to be the parameters most frequently correlating with cognitive decline. These gait endpoints were selected for assessment using the smart-insoles. **Balance:** Two healthy subjects, A and B fitted smart-insoles into loose flat shoes and carried out a number of tests to mimic the Berg Balance assessment. The exercise was carried out in sequence with eyes open followed by eyes closed to induce balance instability. Each assessment lasted 60 seconds and repeated 5 times ; **Static stance** on two feet, shoulder width apart eyes open and eyes closed, **Single foot stance** (right and then left) eyes open and eyes closed. Subject A repeated the static stance with the insoles fitted into 3 different shoes; Comfortable flat shoes, tight flat shoes, high heels shoes. **Gait:** With the insoles in flat shoe B walked 70 metres at different speeds. Using a metronome to set the pace of 60 beats per minute (bpm), 90bpm, 120 bpm, 150bpm and a "free walk" without the metronome where the pace changed from slow to fast, fast to medium, medium to fact and fast to slow. To assess stride variation we looked at swing duration; that is the amount of time that passes during the swing phase of one extremity in a gait cycle. The standard deviation of swing duration reflects the variation from one stride to another. **Results:** **Balance:** The smart insoles generate data from 13 embedded tri-axial accelerometers each capable of generating 100hertz data. For this proof of concept we focused on the centre of pressure (COP) and its standard deviation to assess balance change. Using eyes closed to simulate balance instability and variance of the average standard deviation for the static balance activities increased two fold when carried out with eyes closed compared with eyes open. **Flat shoe vs. Heeled shoes;** each shoes type generated a significantly different COP with the heeled shoe generating a negative COP in the X axis reflecting the altered stance due to the shoe type. Thus showing the impact of

changing the shoe type on the assessment outcome. Gait: Using a Metronome to set the pace we are able measure the cadence (steps per second) for each walking speed. As the walking speed increased the standard deviation of stride variation increased. It was difficult for subject B to maintain the 150bpm walk and this walk period had the highest standard deviation of swing duration (Table 1). **Conclusion:** Using smart insoles we were able to quantify gait speed and stride variability. The potential value of smart-insoles is in the portability of the technology that would enable their use outside of specialist gait clinics and potentially to monitor gait change in the individual's home or residential care setting. These devices generate vast quantities of data leading to the possibility of using machine learning and data analytics platforms to identify new clinical sensitive signals within the data set. It was outside the scope of this pilot to determine the minimal clinically important differences (MCID) for cognitive decline; this would require a significant body of research. In addition it should be noted that factors such as footwear and data transfer could impact the operationalization of these devices in clinical trial and needs careful consideration before implementation in a clinical trial.

Table 1
Average Standard Deviation of Swing Duration

	90bpm		120bpm		150bpm		Free walk	
	Left	Right	Left	Right	Left	Right	Left	Right
StDev of Swing Duration (s)	0.02	0.02	0.16	0.14	0.31	0.40	0.20	0.18

LBP46: USING THE POWER OF DEMENTIAS PLATFORM UK (DPUK) COHORTS TO INVESTIGATE THE LONGITUDINAL EFFECTS OF CHILDHOOD ADVERSITY ON ADULT COGNITION AND HEALTH OUTCOMES: IMPLICATIONS FOR COGNITIVE CHANGE AND DEMENTIA OUTCOMES. Sarah Bauermeister, John Gallacher (University of Oxford, Department of Psychiatry, Oxford, UK)

Background: Childhood adversity is a broad construct encompassing extreme difficulties and adverse experiences during childhood such as sexual, physical and emotional abuse, deprivation, and family dysfunction (e.g., YoungMinds, 2016). These adverse childhood experiences (ACEs) are considered highly stressful and traumatic, occur during childhood or adolescence and are independent of the normal stresses which accompany natural childhood growth and development. Experiencing adversity within childhood alters the life of a child and may change some biological processes leading to adverse biomedical health outcomes in adulthood (Mehta et al., 2013). Childhood adversity is also associated with adult depression (Liu, 2017), lower adult life satisfaction (Hughes et al., 2016), and dementia (Radford et al., 2017). In dementia-focused epidemiological studies where a rich biographical background is collected, factors such as childhood experiences are not always collected as an integral component of family history, or indeed, if they are, they are minimal. However, as childhood adversity is a complex and sensitive topic to investigate in birth cohorts (i.e., in children), the opportunity to collect these type of data could be maximised in population cohorts, considering existing associations with adult outcomes, specifically cognition and dementia outcomes. **Objectives:** Our aim is to investigate associations between childhood adversity and multiple adult

health-related outcomes (behavioural, psychological, cognitive and biomedical) utilising retrospective self-report scales across selected Dementias Platform UK (DPUK) population cohorts. We present our preliminary findings from three cohorts in a cross-cohort comparison study. **Methods:** Data from UK Biobank (n = 479,739), the English Longitudinal Study of Ageing - ELSA (n = 12,651) and the MRC National Survey of Health and Development 1946 - NSHD (n = 3,667) studies were used in this study. Self-report retrospective questionnaire data were selected across the cohorts to extract variable measures of ACEs, e.g., 'People in my family hit me so hard that it left me with bruises or marks' (UK Biobank); 'Mother and father made me feel I wasn't wanted' (MRC NSHD); 'When aged < 16 was physically abused by your parents' (ELSA). Structural equation modelling (SEM) was used to assess the prediction pathways between ACEs and adult outcome variables. The individual ACE variables (questions) were entered into the models as reflexive indicators of the latent or factor constructs of childhood adversity. The adult outcome variables across behavioural, psychological and cognitive categories were entered individually into the model. Models adjusted for age, socioeconomic status (SES), education and income when these variables were not included as an outcome. **Results:** Childhood adversity significantly predicted higher frequency of alcohol intake, increased smoking, medication usage, BMI, neuroticism, depression, and lower levels of life satisfaction, happiness and cognition across all three cohorts (mostly p < .000). Importantly, these findings were analysed utilising multiple different types of retrospective measures of childhood adversity, extracted self-reported scale measures, across existing population cohorts. Across each of these cohorts, these measures were combined either as latent constructs of childhood adversity (UK Biobank and ELSA) or as a factor score (MRC NSHD). **Conclusions:** The implication of this work is two-fold, that population cohorts may provide important information which is not at first overtly evident but may be extracted through statistical procedures. Secondly, this work highlights the implication of childhood adversity on adult outcomes and the follow-on work using other DPUK cohorts will extend these investigations to include longitudinal work investigating accumulative neurobiological load, childhood adversity and dementia. Other cohorts to be included in this study: Whitehall II, the Avon Longitudinal Study of Parents and Children (ALSPAC) and TwinsUK. **References:** Hughes, K., Lowey, H., Quigg, Z. & Bellis, M.A. (2016). Relationships between adverse childhood experiences and adult mental well-being: Results from an English national household survey. *BMC Public Health*: 16(222). Liu, R. (2017). Childhood adversities and depression adulthood: Current findings and future directions. *Clinical Psychology Science and Practice*. 24(2):140-149. Mehta, N.M., Corkins, M.R., Lyman, B., Malone, B., Malone, A., Goday, P.S., Carney, L.N.,... (2013). Defining pediatric malnutrition: a paradigm shift toward etiology-related definitions. *JPEN J Parenter Enteral Nutr*. 37(4):460-481. Radford, K., Delbaere, K., Draper, B., Mack, H.A., Daylight, G., Cumming, R., Chalkley, S., Monogue, C., & Broe, G.A. (2017). Childhood stress and adversity is associated with late-life dementia in aboriginal Australians. *Am J Geriatr Psychiatry*. 25(10):1097-1106. YoungMinds Trust (2016). Addressing Adversity. Prioritising adversity and trauma-informed care for children and young people in England. UK Biobank study application 15697

Theme: Cognitive assessment and clinical trials

LBP47: STRATEGIC MEMORY ALZHEIMERS REHABILITATION TRAINING (SMART) MEMORY PROGRAM FOR AMNESTIC MILD COGNITIVE IMPAIRMENT (AMCI): REPORTING THE RESULTS OF A RANDOMIZED CLINICAL TRIAL. John W. DenBoer (*SMART Brain Aging, Inc.*)

The combined effects of the aging of the population (caused by the shift of the baby boomer generation into dementia) and significant increase in life expectancy has combined to put dementia into the range of our largest medical, if not societal, problems. In the state of Arizona, there is a projected 44-72% increase in dementia. Research has supported the use of cognitive intervention exercises to reduce early-stage dementia. Valenzuela and Sachdev (2009), in a literature review of 22 studies (involving approximately almost 30,000 individuals), found an overall risk reduction of 46% in individuals that were found to engage in a high level of regular cognitive activity. Perhaps more importantly, they found a dose-dependent relationship between cognitive exercise and reduction of dementia, which had not been found previously. The SMART Memory Program (DenBoer, 2008) is a cognitive intervention designed to promote the reduction of early-stage dementia. Results of this program have shown significant promise (e.g., DenBoer, 2013), and the present researchers are currently engaging in multiple research studies. The program is effective via the use of new and novel cognitive exercises. The researchers have conducted a randomized clinical trial (RCT), which is considered the gold-standard of research in this area. This presentation focuses on the results of a joint study with UCLA in which the researchers examined the effects of the SMART Brain U Online program on individuals with amnesic MCI (aMCI).

LBP48: MEMORY ERRORS OF COMMISSION RATHER THAN ERRORS OF OMISSION DISCERN AGING AND EARLY ALZHEIMER'S DISEASE. Matthias W. Riepe, Claudia Lanza, Karolina Sejunaite (*Department of Psychiatry and Psychotherapy II, Mental Health & Old Age Psychiatry, Ulm University, Ulm, Germany*)

Background: Memory failure is a hallmark of early Alzheimer's disease. However, a slight decline of memory with healthy aging is also established. Thus it would appear that it is only a quantitative difference between healthy aging and Alzheimer's disease. In everyday life memory failure, however, may not only result in incomplete recall of information but also in distorted recall of information. **Objective:** The goal of the present study was to assess omissions and distortions of memory in a task with day-to-day relevance in healthy young and old subjects and patients with Alzheimer's disease. **Method:** We investigated healthy young (YA; age 26.6±3.6 years) and old adults (OA; age 69.7±6.5 years), and patients with early Alzheimer's disease (AD; 72.2 ± 5.9 years). Participants were assessed with a standard neuropsychological battery comprising measures of attention (digit span, block span), executive function (Trail making Test) and memory (California Verbal Learning Test). In addition participants were asked to watch a selection of six news and commercials each and answer questions on the content of these video clips. **Results:** Total number of items recalled veridically was smaller in OA and AD

for both standard list learning and the news and commercials memory tasks. In contrast to age-associated decline of veridical memory recall, the number of false memories was unrelated to age and similar in YA and OA. However, patients with early AD (MMSE26.9±1.9) had an increased number of memory distortions. In patients with AD, levels of Abeta1,42 in the cerebrospinal fluid but not levels of tau protein were correlated with the number of false memories in both the commercials and news task. **Conclusion:** As expected the number of items recalled veridically from a list of words or from viewing news or commercials declines slightly with age and markedly in patients with early Alzheimer's disease. In contrast, the number of memory distortions is not dependent on age. In patients with early AD the number of memory distortions is increased and correlates with Abeta1,42 in the cerebrospinal fluid. Thus, memory failure in patients with early AD is qualitatively different from memory failure in aging and associated with markers of amyloid pathology. Assessment of false memory thus is a promising marker for clinical trials in patients with amyloid pathology.

LBP49: STANDARD COGNITIVE ASSESSMENT IN THE ERA OF BIOMARKERS AND DISEASE-MODIFIERS. Marina Boccardi^{1,2}, Stefano Cappa², Bruno Dubois³, Jean Georges⁴, Matthias Kliegel⁵, Bengt Winblad⁶, David Salmon⁷, Giovanni Frisoni^{1,2}, Andreas Monsch⁸ for the Task Force for Harmonizing Neuropsychological Assessment for Dementing Neurodegenerative Disorders ((1) LANVIE - Laboratory of Neuroimaging of Aging, University of Geneva, Geneva, Switzerland; (2) IRCCS S.Giovanni di Dio - Fatebenefratelli, Brescia, Italy; (3) Dementia Research Center, Hôpital Pitié-Salpêtrière, Paris, France; (4) Alzheimer Europe; (5) Laboratory of Cognitive Aging, University of Geneva, Geneva, Switzerland; (6) Karolinska University Hospital, Stockholm, Sweden; (7) Department of Neurosciences, University of California San Diego School of Medicine, United States; (8) University of Basel, Basel, Switzerland)

Background: Cognitive assessment is key in the diagnostic procedure of Alzheimer's disease (AD) and related disorders. Currently, it is performed with heterogeneous batteries across memory clinics. A standard assessment is urgently needed, to prescribe diagnostic biomarkers based on their demonstrated predictive values. Other standard assessment protocols will soon be urgent also for other different avails, i.e., to prescribe biomarkers for their theragnostic value, or to perform drug administration surveillance in Phase 4 studies of the disease modifiers that may soon be marketed. However, the use of multiple assessment protocols is costly, superfluous, and liable to uncontrolled practice effects in patients. One homogeneous methodology needs to be devised for a consistent assessment preventing redundant, superfluous, costly and confounding testing. **Objectives:** To identify a consistent methodological framework required to define a single standard cognitive assessment adequate to the different contexts of use (diagnostic, theragnostic, phase 4 surveillance). **Methods:** We converged a) experts from previous harmonization initiatives from three continents, and b) physicians and clinical neuropsychologists from primary and tertiary memory clinics and stakeholders in Europe, to join a dedicated consortium. We met in person at a workshop in Geneva in May 2018, run formal and informal consensual procedures, and charged working subgroups with specific thematic searches. **Results:** So far, the consortium achieved consensual definitions for: the normal population

(selected healthy subjects, with exclusion of hyper-normals); a standard classification of education (three levels: 1) primary and lower secondary, 2) upper secondary, 3) post-secondary) to account for the heterogeneous education systems, as based on the International Standard Classification of Education (ISCED); the minimum sample size for obtaining normative values (8 subject per cell, by 3 classes of education, by 6 age decades), and the underlying statistical models. Subsequent consultations to define a standard NPS will be based on the DSM-5 framework of neurocognitive disorders and the US NACC Uniform Data Set (UDS) version 3-plus, the most advanced standard assessment for AD and related disorders to date. **Conclusions:** We converged a wide consortium for solving the issue of the standard assessment for AD and related disorders. The methodology for a unitary framework is defined to an important extent. The definition of the specific standard assessment is ongoing. It will be based on evidence and expert consensus, and should cover the different contexts of use, in order to minimize repeated testing. The standard cognitive assessment should ideally be integrated with a standard outcome assessment: this should equally be defined by capitalizing on previous and ongoing harmonization projects, know-how and networks, and using a consistent methodology.

LBP50: LANABECSTAT: RATER PERFORMANCE AND ERROR CHARACTERISTICS OF EFFICACY ASSESSMENTS IN THE DAYBREAK-ALZ STUDY. Alette M. Wessels¹, Jordan Mark Barbone², Danielle T. DiGregorio², David S. Miller², Jamie A. Mullen³, John R. Sims¹ ((1) *Eli Lilly and Company, Indianapolis, IN, USA*; (2) *Bracket, Wayne, PA, USA* (3) *AstraZeneca Pharmaceuticals, Cambridge, MA, USA*)

Background: Lanabecestat is a brain-permeable, oral inhibitor of human beta-site amyloid (A β) precursor protein-cleaving enzyme 1 (BACE1) that reduces A β production. Lanabecestat was under investigation as a potential disease-modifying treatment for Alzheimer's disease (AD). The primary outcome efficacy assessment of the global phase 3 study DAYBREAK-ALZ is the 13-item version of the Alzheimer's Disease Assessment Scale—Cognitive subscale (ADAS-Cog13). Inclusionary and secondary efficacy assessments include the Clinical Dementia Rating Scale (CDR) and the Mini-Mental State Examination (MMSE). **Objectives:** The DAYBREAK-ALZ study (NCT02783573) utilized a rater performance and data-quality monitoring program that includes the review of scale worksheets and audio recordings of scale administration. Here we describe the rater error characteristics on the efficacy assessments. **Methods:** In order to be considered as potential raters, specific educational, clinical experience with the study population and prior scale administration criteria needed to be met. Raters were then required to receive training on proper scale administration and scoring. For the ADAS-Cog, raters also needed to watch and score an actual scale administration to criteria, and successfully complete an interview skills assessment. CDR raters also had to successfully complete and receive certification through Washington University's online CDR training program. For the MMSE once raters met the pre-specified experience criteria, they only had to complete the training. The ADAS-Cog13 and the MMSE were administered with a tablet and CDR was administered using a paper worksheet. Administration audio for all scales were captured on a separate recording device. Scales were assessed for scoring and administration accuracy in adherence to specific study

conventions. Administration quality was assessed through the audio recordings and scoring quality through review of electronic/paper record and audio recordings. Remediation of errors was conducted via email or telephone by a Central Reviewer in the rater's local language. **Results:** The study included 864 raters from 18 countries and 19 language translations. Across the three efficacy scales, 20,889 scale submissions were assessed on quality. Of the 5,990 ADAS-Cog reviews, 1,658 (27.68%) were flagged for administration issues and 1,414 (23.61%) for scoring issues. For the 9,759 MMSE reviews, 1,388 (14.22%) were flagged for administration and 1110 (11.37%) flagged for scoring issues. As there was no audio review for the CDR, administration quality was not assessed. Of the 5,140 CDR reviews, 1,050 (20.43%) were flagged for scoring issues (Table 1). The results in Figure 1 provide an Item analysis of the domain errors for the ADAS-Cog, MMSE, and CDR as well as the type of error (i.e., administration or scoring). The most flagged domains for combined scoring and administration of the ADAS-Cog were Number Cancellation and Constructional Praxis; for administration errors, Word Recognition had the highest rate at over 12% of all reviewed ADAS-Cog assessments. On the MMSE, higher combined error rates were found for Attention and Calculation, Orientation to Place, and Writing but were relatively lower than those seen on the ADAS-Cog. The Attention & Calculation and Writing tasks had the highest rates of administration errors while Orientation to Place and Orientation to Time showed the highest rates of scoring errors. On the CDR, the Orientation domain showed the highest error rate at nearly 4% of all reviews. **Conclusion:** The addition of audio reviews of recorded scale administrations to the review of scale scoring data allows for the identification and remediation of administration and scoring errors which otherwise would be indiscernible. This analysis found similarly higher error rates in specific domains of the ADAS-Cog (e.g., administration of Word Recognition and Naming; scoring of Constructional Praxis and Number Cancellation) and the MMSE (e.g., administration of Attention & Calculation and Orientation; scoring of Orientation) seen across several study programs. This highlights the additional benefit audio provides to data quality.

Table 1
Summary of overall errors detected across assessments

Scale	Reviews	Administration (%)	Scoring (%)	Either (%)	Both (%)
ADAS-Cog	5,990	27.68	23.61	37.23	14.06
CDR ¹	5,140	-	20.43	-	-
MMSE	9,759	14.22	11.37	21.17	4.43

¹ CDR did not contain audio review therefore administration error detection excluded.

Figure 1

Rates of item level flags for scoring and administrations

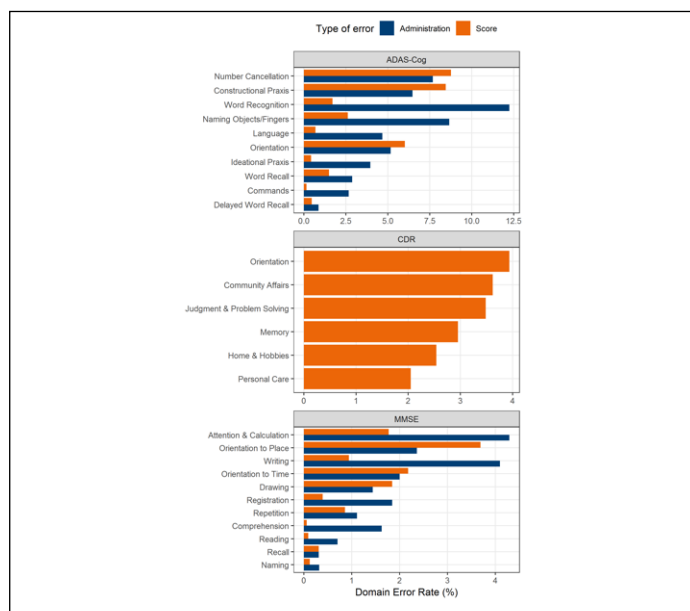

LBP51: iPSC MODEL OF CHRFA7A EFFECT ON A7 NICOTINIC ACETYLCHOLINE RECEPTOR FUNCTION MAY EXPLAIN THE TRANSLATIONAL GAP IN DRUG DEVELOPMENT. Ivanna Ihnatovych¹, Tapan Nayak¹, Aya Ouf¹, Norbert Sule², Barbara Birkaya¹, Lee Chaves¹, Anthony Auerbach¹ ((1) SUNY at Buffalo; (2) Roswell Park Cancer Institute)

Background: The $\alpha 7$ nicotinic acetylcholine receptor ($\alpha 7$ nAChR) is a ligand-gated ion channel implicated in cognition and neuropsychiatric disorders. $\alpha 7$ nAChRs co-localize with brain regions underlying cognition and memory, and are the regulators of the cholinergic anti-inflammatory pathway. Amyloid beta 1-42 ($A\beta 1-42$) binds with high affinity to the $\alpha 7$ nAChRs and the receptor facilitates internalization of $A\beta 1-42$ suggesting that neurons expressing the CHRFA7 may be selectively vulnerable in AD. A unique feature of the $\alpha 7$ AChR is the presence of a human specific fusion gene, CHRFA7A. CHRFA7A harbors exons 6-10 of CHRFA7 and 5 new exons of the FAM7 sequence. CHRFA7A is present in different copy number variations (CNV) and orientation in the human genome with high frequency. GWAS reported an association between CHRFA7A dosage and AD, lower copy number and lower expression level of CHRFA7A is associated with AD. In contrast, in schizophrenia and bipolar disorder, upregulation of CHRFA7A was observed and it is associated with the inverted orientation (2 bp deletion). **Objectives:** $\alpha 7$ nAChR is a promising target for diseases affecting cognition and higher cortical functions, however the effect observed in animal models failed to translate into human clinical trials identifying a translational gap. As CHRFA7A is a human specific fusion gene its effect was not accounted for in preclinical studies. We hypothesized that CHRFA7A may account for this translational gap; understanding of its function may offer novel approaches to explore it as a drug target. **Methods:** To study the functional consequences of the presence of the CHRFA7A, two iPSC lines (0 copy and 1 copy direct) were developed and characterized (RT-qPCR, ICC, the TaqMan hPSC Scorecard Assay). iPSCs were differentiated into Medial

Ganglionic Eminence progenitors (MGE) and into BFCN and GABA interneurons. MGE progenitors were transfected with pcDNA3.1-CHRFA7A-mCherry. Live α -BGT staining (Wang et al., 2003), whole cell and single-channel patch clamp were performed to demonstrate functionality of generated neurons. Kinetic analyses of single channel currents were carried out by using QuB (Milescu et al., 2003). Amyloid beta uptake was assessed by treating MGE progenitors with various (1nM – 250 nM) concentrations of Fluorescein- $A\beta 1-42$ (Hu et al., 2009). Live images were taken using EVOS microscope. Confocal images were taken with LSM510 Meta microscope. $A\beta 1-42$ uptake was quantified by ImageJ or Flow cytometry using LSR II-B with FACS DIVA (www.denovosoftware.com). Following $A\beta 1-42$ uptake, concentration of secreted IL-1 β was estimated using a human specific high sensitivity IL-1 β ELISA kit. **Results:** RT-qPCR with CHRFA7 and CHRFA7A breakpoint (unique sequence) primers demonstrated expression of CHRFA7 (in UB068 and UB052) and gradually increasing expression of CHRFA7A (in UB052) during neuronal differentiation (D0 - pluripotent iPSC; D25 - MGE progenitors; and D40 - neurons). Live staining with α -BGT and single channel patch-clamp with α -selective antagonist MLA confirmed the presence of functional $\alpha 7$ nAChR in neurons generated from both iPSC lines. As readouts for genotype-phenotype correlation, $\alpha 7$ nAChR synaptic transmission and $A\beta 1-42$ uptake were tested. CHRFA7A is a modulator of the $\alpha 7$ nAChR: $\alpha 7$ nAChRs currents in neurons derived from UB068 and UB052 lines were pharmacologically characterized by utilizing the positive allosteric modulator (PAM) PNU 120596. PNU in UB068 cells progressively increased channel open probability of single $\alpha 7$ AChRs in a time-dependent manner. Whereas in UB052, PNU modulated currents desensitized/ran down faster than UB068. Comparative nPo analyses of currents from both cell-types showed a clear difference in kinetic properties, suggesting a CHRFA7A effect. It was confirmed by transfection of HEK293 cells with CHRFA7 and CHRFA7A in the ratio 1:4 and 4:1. nPo analyses of both currents suggested that desensitization of PNU-modulated $\alpha 7$ nAChR currents increased as a function of CHRFA7A dosage consistent with the results contrasting UB068 and UB052. Amyloid beta uptake via the $\alpha 7$ nAChR and activation of inflammatory pathways by $A\beta 1-42$ is mitigated by CHRFA7A: $A\beta 1-42$ uptake demonstrated that the presence of CHRFA7A leads to a decrease in $A\beta 1-42$ uptake. In UB068 (CHRFA7A null) line, $A\beta 1-42$ uptake was higher and dose dependent compared to UB052 (1 direct CNV CHRFA7A), where it was constant between concentration of 25 nM to 250 nM. Transfection of UB068 with CHRFA7A caused a decrease in $A\beta 1-42$ uptake and the pattern of uptake reminded the one registered in UB052. Furthermore, in the presence of CHRFA7A $A\beta 1-42$ uptake activated neuronal IL-1 β and TNF α without activating the inflammasome. **Conclusions:** These results suggest a negative modulatory effect of CHRFA7A on synaptic transmission (relevance in schizophrenia) and a modulatory effect on $A\beta 1-42$ uptake (relevance in AD), consistent with the direction of the association signals in schizophrenia (increased CHRFA7A as risk) and AD (loss of CHRFA7A as risk). CHRFA7A mitigated the dose response of $A\beta 1-42$ uptake, suggesting a protective effect beyond physiological concentrations and modulated $\alpha 7$ nAChR. Lead optimization may identify more potent molecules when the screen has a model harboring CHRFA7A. Incorporating pharmacogenetics into clinical trials may enhance signals.

LBP52: EFFECTS OF AGE AND CSF MEASURES OF TAU ON MNEMONIC DISCRIMINATION OF OBJECTS AND SCENES IN MEDIAL TEMPORAL LOBE PATHWAYS.

David Berron^{1,2,3}, Arturo Cardenas-Blanco⁴, Daniel Bittner², Coraline D. Metzger⁵, Annika Spottke^{6,7}, Michael Heneka^{7,8}, Klaus Fließbach^{9,10}, Anja Schneider^{7,8}, Stefan J. Teipel^{11,12}, Michael Wagner^{7,13}, Oliver Speck¹⁴, Frank Jessen^{7,15}, Emrah Düzel^{4,5} the DELCODE study group ((1) *Clinical Memory Research Unit, Department of Clinical Sciences Malmö, Lund University, Lund, Sweden*; (2) *University Hospital Magdeburg, Magdeburg, Germany*; (3) *German Center for Neurodegenerative Diseases, Magdeburg, Germany*; (4) *German Center for Neurodegenerative Diseases (DZNE), Magdeburg, Germany*; (5) *Institute of Cognitive Neurology and Dementia Research (IKND), Otto-von-Guericke University, Magdeburg, Germany*; (6) *Department of Neurology, University Hospital of Bonn, Bonn, Germany*; (7) *German Center for Neurodegenerative Diseases (DZNE), Bonn, Germany*; (8) *Department for Neurodegenerative Diseases and Geriatric Psychiatry, University Hospital Bonn, Bonn, Germany*; (9) *DZNE, German Center for Neurodegenerative Diseases, Bonn, Germany*; (10) *Department of Psychiatry and Psychotherapy, University of Bonn, Bonn, Germany*; (11) *Department of Psychosomatic Medicine, Rostock University Medical Center, Rostock, Germany*; (12) *German Center for Neurodegenerative Diseases, Rostock, Germany*; (13) *Department of Neurodegenerative Diseases and Geriatric Psychiatry, University Hospital, Bonn, Germany*; (14) *Department of Biomedical Magnetic Resonance, Otto-von-Guericke University, Magdeburg, Germany*; (15) *Department of Psychiatry, University Hospital Cologne, Cologne, Germany*)

Introduction: Functional pathways in the medial temporal lobe are differentially involved in memory of objects and scenes and also differentially affected by Alzheimer's disease pathology. However, it is unclear whether object or scene memory are affected earlier in ageing and preclinical Alzheimer's disease. **Objectives:** First, we developed a novel mnemonic discrimination task where subjects had to discriminate similar versions of objects and scenes (Berron et al., 2018). In a first functional magnetic resonance imaging (fMRI) experiment, we compared the neuronal activity patterns of healthy older and young subjects. Second, in order to test whether tau pathology is associated to domain-specific memory impairment in cognitively normal older individuals, we investigated the effects of phosphorylated Tau (p-Tau) levels in CSF on memory function and fMRI activity in the medial temporal lobe of healthy older adults within the DELCODE study. **Discussion:** We found that object and scene mnemonic discrimination relies on different MTL memory pathways. While scene memory mainly activates the precuneus, retrosplenial cortex, parahippocampal cortex and the posterior-medial entorhinal cortex, object memory activates the lateral occipital complex, fusiform gyrus, perirhinal cortex, the amygdala and the anterior-lateral entorhinal cortex. While young individuals showed a clear dissociation of object and scene memory in the perirhinal cortex, older individuals showed a significant reduction in domain-specific activity which was associated to reduced object memory performance. This relationship was replicated in the 21 healthy older adults within the DELCODE study. Here we also found that CSF p-Tau levels were associated to hippocampal hyperactivity which in turn was associated to reduced object memory performance. **Conclusion:** Our findings demonstrate that the anterior-temporal object memory pathway is affected predominantly

in ageing and that tau pathology is associated to impairment in object but not scene memory. Our fMRI results furthermore show that tau pathology is associated to hyperactivity in the hippocampus and this suggests a possible mechanism of early impairment in ageing.

Theme: Behavioral disorders and clinical trials

LBP53: PREVALENCE OF OBSTRUCTIVE SLEEP APNEA IN ALZHEIMER'S DISEASE PATIENTS.

Anna Carnes¹, Carme Jorge¹, Benítez^{2,3}, Faride Dakterzada¹, Olga Minguez², Raquel Huerto¹, Montse Pujol², Anna Gaeta², Alfonso Arias¹, Aurora Gibert¹, Manuel Sanchez de la Torres^{2,3}, Ferran Barbé^{2,3}, Gerard Piñol-Ripoll¹ ((1) *Unitat Trastorns Cognitius, Clinical Neuroscience Research, IRBLleida-Hospital Universitari Santa Maria, Lleida, Spain*; (2) *Group of Translational Research in Respiratory Medicine, Hospital Universitari Arnau de Vilanova and Santa Maria, IRBLleida, Lleida, Spain*; (3) *Centro de Investigación Biomédica en Red de Enfermedades Respiratorias (CIBERES), Madrid, Spain*)

Objective: To assess the prevalence of Obstructive Sleep Apnea (OSA) in patients with mild-moderate AD and evaluate cognitive characteristics according the severity of OSA. **Methods:** Patients with mild-moderate AD, recruited prospectively from a cognitive impairment unit, underwent overnight polysomnography. OSA was defined as an apnea-hypopnea index (AHI) >5/h. AD severity was assessed using Minimal State Examination (MMSE) and extensive neuropsychological battery. Behavioral symptoms were assessed using Cornell Depression Scale and Neuropsychiatric Inventory (NPI), Epworth Sleepiness Scale (ESS). APOE status was analyzed. **Results:** The mean age of 128 patients in the study was 75.25 (5.27), 57.8% of patients were women. Nicturia (89,06%), loss of concentrations (78,13%) and snoring (71,09%) were most common symptoms. Patient didn't present excessive daytime sleepiness with ESS score in normal range 5 (3.00;8.00). OSA was diagnosed in 115 subjects (90%). The distribution of severity of OSA was 29 (23%), 37 (29%) and 50 (39%) with respect to mild, moderate and severe. Participants with severe OSA included a higher proportion of older man, snoring and sedentariness in addition to a higher value of overall anthropometric variables. Not significantly differences in cognitive assessment were found between patients with and without severe OSA. Subjects with severe intermittent hypoxemia presented better performances in visual memory (p <0.05). The genotypes and allele frequencies of the combination of the polymorphisms of the APOE gene tested (e2, C112R / e3 C158R) were not significantly different between patients with and without severe OSA. **Conclusion:** High prevalence of OSA in patients with mild AD. OSA was not associated with sleepiness and worse cognitive function in AD. Severe intermittent hypoxemia was associated to better performances verbal memory. Further longitudinal studies will be required to evaluate whether OSA impairs cognitive evolution of AD patients.

Theme: Clinical trials: Epidemiology and clinical trials

LBP54: PSYCHOMETRIC METHODOLOGIES TO INCREASE SCALE-RELIABILITY IN DEMENTIA-FOCUSED EPIDEMIOLOGY: OUTCOMES FROM THE EUROPEAN PREVENTION OF ALZHEIMER'S DISEASE STUDY AND UK BIOBANK. Sarah Bauermeister, John Gallacher (*University of Oxford, Department of Psychiatry, Oxford, UK*)

Background: Self-report scales for detecting longitudinal change in epidemiological research are frequently used as a brief measure of psychosocial measures such as mental health, personality and quality-of-life. However, few scales are specifically designed for epidemiologic use and in an epidemiological context, may be psychometrically inefficient. Importantly, in a dementia context, such scales are often utilised as covariates or predictors in statistical models. Moreover, poor mental health is associated with cognitive deficits in old age (Bauermeister & Bunce, 2015) and depression is found in 50% of older adults with symptoms of dementia (e.g., McNeil, 1996). Assessing longitudinal trajectories of depressive disorders in dementia-focused studies such as the European Prevention of Alzheimer's Disease Longitudinal Study (EPAD LCS) is of utmost importance. However, those older adults experiencing depressive symptoms or those with dexterity and learning difficulties may find that long or ambiguous questionnaires are incomprehensible, or cause mental fatigue. This in turn, may have a negative effect on scale reliability and participant retention. Furthermore, many widely-used and well-established scales were not developed using psychometric methodologies and have not been revised or updated for many years. As a result, selected scales may be unreliable or outdated, and also not suitable for large cohort epidemiological studies where repeat-testing is required. Longitudinal studies such as the EPAD LCS rely on measures which are reliable, efficient and easy to administer. Importantly, when studying an ageing population which may include persons with cognitive impairment, these scales need to be minimally invasive, brief and reliable. Utilising advanced psychometric methodologies and adapting selected scales into the format of Computer Adaptive Tests (CATs), may address these concerns. One methodology traditionally used in educational testing is the mathematical estimation method of Item Response Theory (IRT), a method which estimates a latent trait construct (i.e., depression) whilst also providing individual item-level information (i.e., information about each item within a scale rather than just about the total scale). CATs are adaptive, utilising an IRT model, a standard error cut off point, and as such, the two methods together provide a high level of scale delivery and analysis thereby providing potential for increased reliability and reduced participant test burden. Here we present our developing work in this field, aiming to improve scale reliability and delivery across scales in dementia-focused epidemiological focused studies such as the EPAD LCS and UK Biobank. **Objectives:** To analyse existing, well established scales to provide item-level information through advanced psychometric methodologies. To propose the design of CAT technologies for scale delivery across selected scales. **Methods:** We present psychometric output from the EPAD LCS Geriatric Depression Scale (GDS: Yesavage et al., 1983) to which we apply a graded-response response model (IRT GRM) and extract item-level information to obtain the difficulty and discrimination

values across the first 500 participants of the EPAD LCS. We also compute mathematical assumptions to test the reliability of the scale using a Mokken analysis. Furthermore, we utilise the results of the GDS scale output from the EPAD LCS to design a CAT version of the scale to present how this scale might be reduced using adaptive technologies. Our preliminary work suggests that when a person endorses a depressive trait scale item, the entire scale is shortened by one third as the CAT 'learns' and adapts the items to the respondent, ending when a pre-set reliability cut-off has been reached (i.e., 95%). **Results:** We also present the results of a psychometric analysis from the 12-item UK Biobank EPQ-R Neuroticism scale to which we applied a two-parameter model (2-PL IRT) and computed all assumptions across 384,062 participants. For the EPQ-R scale, a plot of θ values (Item Information functions) shows most items cluster around the mid-range. The mean for individual item θ scores varies between -0.13 and 1.42 with no items measuring extreme trait values (< -2 to $> +2$) suggesting limitations within the scale. Our psychometric research suggests that selected scales may be inefficient with poor discrimination, at the extremes of the scale-range i.e. high and low scores are relatively poorly represented and uninformative. When a plot of informativeness overlaid by the standard error of measurement, it showed poor reliability at the extremes of scale score (neuroticism). This suggests that high neuroticism scores derived from the EPQ-R are a function of cumulative mid-range values. **Conclusions:** Utilising psychometric methodologies provides additional item-level information for scale development and adapting overly long scales such as the GDS into a CAT format may reduce participant test fatigue and increase reliability as our preliminary work suggests. These data demonstrate the potential for a new generation of psychometrically efficient tests for use in epidemiologic and other studies where there is a desire to reduce the participant burden.

LBP55: STOPBANG AND BERLIN QUESTIONNAIRE AS SCREENING TOOLS TO IDENTIFY OBSTRUCTIVE SLEEP APNEA IN ALZHEIMER'S DISEASE. Anna Carnes¹, Benítez^{2,3}, Faride Dakterzada¹, Olga Minguez², Raquel Huerto¹, Montse Pujol², Anna Gaeta², Alfonso Arias¹, MD, Aurora Gibert¹, Manuel Sanchez de la Torres^{2,3}, Ferran Barbé^{2,3}, Gerard Piñol-Ripoll¹ (1) *Unitat Trastorns Cognitius, Clinical Neuroscience Research, IRBLleida-Hospital Universitari Santa Maria, Lleida, Spain;* (2) *Group of Translational Research in Respiratory Medicine, Hospital Universitari Arnau de Vilanova and Santa Maria, IRBLleida, Lleida, Spain;* (3) *Centro de Investigación Biomédica en Red de Enfermedades Respiratorias (CIBERES), Madrid, Spain*)

Background: Relationship between obstructive sleep apnea (OSA) and Alzheimer's disease (AD) had been described in recent years. OSA is a risk factor for AD disease but little is known about the diagnosis or clinical characteristics of these patients. This study evaluated the clinical utility of two screening questionnaires such as STOP-Bang (SBQ) and Berlin questionnaires (BQ) to identify which patients with mild AD were at higher risk to having OSA and to determine clinical predictors of OSA in this population. **Methods:** Ninety-one outpatients with mild AD were evaluated prospectively and consecutively according SBQ and BQ. All of them were studied by gold standard test such as polysomnography. Predictive performance of questionnaires was calculated for different cut off of apnea-hypopnea index (AHI). **Results:** The mean age

was 76.0 (73.0;80.0) years and 58 (63.7%) were female. Eighty one patients (89.02%) were found to have OSA defined by an AHI > 5h. Predictive performance comparing SBQ to BQ showed higher diagnostic sensitivity (85% vs 4%), lower specificity (35% vs. 96%), lower positive predictive value (PPV) (44% vs 33%) and higher negative predictive value (NPV) (80% vs 65%) to SBQ to detect severe OSA at the cutoff as AHI of 30/h. By itself, none of the items in the two questionnaires predicted the risk of AHI. A version SBQ modified showed a bit greater AUC than SBQ. **Conclusion:** High prevalence of OSA in patients with mild AD. The SBQ and BQ were not good screening tools for the detection of OSA in patients with AD. More sensitive tools will be necessary to correctly identify this group of patients.

LBP56: EXPOSURE TO BENZODIAZEPINES AND DEVELOPMENT OF ALZHEIMER'S DISEASE: A COHORT STUDY IN A HEALTH REGION OF CATALONIA BETWEEN 2002 AND 2015. Carnes A¹, Torres-Bondia FI¹, de Batlle J², Piñol-Ripoll G¹ ((1) *Unitat Trastorns Cognitius, Clinical Neuroscience Research, IRBLleida-Hospital Universitari Santa Maria Lleida, Spain;* (2) *Group of Translational Research in Respiratory Medicine, Hospital Universitari Arnau de Vilanova and Santa Maria, IRBLleida, Lleida, Spain*)

Objectives: Alzheimer's disease (AD) is the main cause of dementia in the western population. Sleep disturbances have been shown to increase the risk of AD, however, benzodiazepine (BZD) consumption has also been shown to increase this risk in some cohort studies. The objective of the study was to assess the risk of AD incidence in a cohort of patients exposed to BZD. **Material and Methods:** A community-based retrospective cohort study, including all individuals assigned, both as a doctor and from the General Practitioner Health Area, belonging to a Health Region of Catalonia (358,157 inhabitants in 2015), from January 1, 2002 to December 31, 2015. Consumptions were expressed in defined daily doses (DDD) accumulated per individual. Three DDD intervals were established (1 - 90, 90 - 180 and > 180). All approved BZDs were included in the Medicines catalog of the Spanish Medicines Agency, as well as the BZD analogues (zopiclone, zolpidem and zaleplon). The variables to be measured were: age, sex, type of Basic Health Area (rural or urban), diagnosis, type of BZD classified according to their average life, (short-intermediate or intermediate-long), and DDD. Since some signs of incipient AD can be treated with BZD, patients treated with BZD during the 5 years immediately prior to diagnosis were excluded. The relationship between the BZD consumption categories and the development of AD was analyzed by Chi2 test and adjusted logistic regression models. Cox proportional hazards models were also used to take into account the time to AD development. **Results:** The cohort included a total of 84,543 individuals consuming BZD and the like with an average age in 2002 of 65 years. During follow-up, 584 new cases of AD were diagnosed. In the Cox models adjusted for year of birth, sex and comorbidities, taking as a reference the first category of BZD consumption (1-90 DDD) there was a 12-fold increase in the risk of developing AD in subjects with cumulative consumption from 90 to 180 DDD (Hazard ratio [95% CI]: 11.6 [3.8-35.7], p-value <0.001) and 78 times higher in subjects with more than 180 accumulated DDD (Hazard ratio [95 % CI]: 78.0 [29.1-208.8], p-value <0.001). The study according to type of BZD revealed slightly higher incidences of AD in the subjects in the highest category of consumption (> 180 DDD) of BZD of

intermediate-long action 1.20% with respect to those of short-intermediate action 1.11%. **Conclusion:** The long-term use of BZD can substantially increase the risk of developing AD. Consequently, the establishment of new treatments with BZD or analogues should be restricted to the most severe cases in which there is an intense disorder, which limits the patient's activity or in situations of significant stress, and should not be prolonged beyond several weeks. Likewise, de-prescription programs for this type of drugs should be developed.

Theme: Animal model and clinical trials

LBP57: ADULT CONDITIONAL BACE1 KNOCKOUT MICE EXHIBIT AXONAL ORGANIZATION DEFECTS IN THE HIPPOCAMPUS. Robert Vassar (*Department of Neurology, Feinberg School of Medicine, Northwestern University, Chicago, USA*)

Background: BACE1 is the β -secretase enzyme that initiates production of the toxic A β peptide that accumulates in the brains of patients with Alzheimer's disease. As such, BACE1 is a prime therapeutic target and several BACE1 inhibitor drugs are currently being tested in clinical trials. However, the safety of BACE1 inhibition is unclear. Germline BACE1 knockout mice have multiple neurological phenotypes, although these could arise from BACE1 deficiency during development. **Objectives:** Determine whether BACE1 gene knockout in postnatal forebrain neurons and in the adult whole body will result in negative phenotypes. **Methods:** Two BACE1 conditional knockout mouse lines were generated in which the BACE1 gene was inactivated in 1) early postnatal excitatory forebrain neurons using a CamKII-cre driver mouse, and 2) the whole body at any age using a tamoxifen-inducible ROSA26-cre-ERT2 driver mouse. Phenotypes of the BACE1 conditional knockout mice were assessed by immunoblot analysis of BACE1 substrates, hippocampus-dependent memory tests, long-term potentiation, EEG, central and peripheral myelination, energy metabolism, neurogenesis, tissue histology, and hippocampal immunohistochemistry. **Results:** We report (1) that postnatal forebrain neuron and tamoxifen-inducible whole body conditional BACE1 knockout mice in which the Bace1 gene is ablated in the adult largely lack the phenotypes observed in germline BACE1 knockout mice. However, one BACE1-null phenotype was induced after BACE1 gene deletion in the adult mouse brain. This phenotype showed reduced length and disorganization of the hippocampal mossy fiber infrapyramidal bundle, the axonal pathway of dentate gyrus granule cells maintained by neurogenesis in the mouse brain. This defect in axonal organization correlated with reduced BACE1-mediated cleavage of the neural cell adhesion protein CHL1, which has previously been associated with axon guidance. **Conclusions:** Although our results indicate that BACE1 inhibition in the adult mouse brain may avoid phenotypes associated with BACE1 deficiency during embryonic and postnatal development, they also suggest that BACE1 inhibitor drugs developed for treating Alzheimer's disease may disrupt the organization of an axonal pathway in the hippocampus, an important structure for learning and memory. References: 1. Ou-Yang, M., Kurz, J.E., Nomura, T., Popovic, J., Rajapaksha, T.W., Dong, H., Contractor, A., Chetkovich, D.M., Tourtellotte, W.G., Vassar, R. (2018). Axonal organization defects in the hippocampus of adult conditional BACE1 knockout mice. *Science Translational Medicine*, 457 (12).

LBP58: DISEASE MODIFYING THERAPY BY TARGETING GENERIC PROTEIN SECONDARY STRUCTURE OF PATHOLOGICAL OLIGOMERS AT ANY STAGES OF ALZHEIMER'S DISEASE MODELS. Fernando Goni, Krystal Herline, Mitchell Marta-Ariza, Frances Prelli, Thomas Wisniewski (*New York University School of Medicine, New York, -USA*)

Background: We have previously demonstrated the feasibility of eliciting a unique antibody response independent of the primary and tertiary structure of proteins/peptides and specifically recognizing generic secondary β -sheet structure dominant on misfolded proteins of oligomeric form; a hallmark of toxic prion-like "infectious" pathology in neurodegenerative diseases and specifically in the dual $A\beta$ and tau Alzheimer's disease (AD) (Goni et al 2013 *J.Neuroinflammation*). As a putative antigen we have used a small peptide with a non-self primary structure, only β -sheet secondary structure and no tertiary structure do to its size. The highly polymerized peptide (pBri) preserved a stable 90% β -sheet secondary structure without any other outstanding epitope that could be recognized by an immune system. Young animals of AD models APP/PS1, 3xTg and SwDI as well as wild type animals, all developed polyclonal antibodies IgM and IgG that recognized oligomers of $A\beta$ and tau and significantly ameliorated pathology. CD-1 animals were used to produce monoclonal antibodies (mAbs) that proved unequivocally the recognition was not to a sequence dependent epitope but to a generic β -sheet secondary structure of pathologic oligomers but not fibrils or native proteins (Goni et al 2017 *Scientific reports*). The mAbs were characterized as specific anti- β -sheet secondary structure monoclonal antibodies ($A\beta$ ComAbs). Either the stable IgM or the engineered IgG $A\beta$ ComAbs could reverse pathology and produce cognitive rescue in 3xTg animals (Goni et al 2018, *Alz Res Therapy*; Herline et al 2018 *Alz Res Therapy*). **Objectives:** To demonstrate that small engineered peptides with similar β -sheet dominant structure but different primary sequences would elicit similar anti- β -sheet responses and ameliorate pathology on 3xTg animals. To demonstrate that old 3xTg animals with already flourished pathology would develop the same type of anti- β -sheet polyclonal IgM and IgG response and compared to $A\beta$ ComAbs infused animals produced comparable cognitive rescue and reduced oligomeric pathology. Finally, to demonstrate the specific reaction to the secondary structure but not the primary/tertiary structure does not produce antibody dependent cerebral microhemorrhages in an old SwDI CAA model of AD. **Methods:** Groups of 8 to 12 male and female 16 months old 3xTg AD and SwDI animals were inoculated i.p. weekly for 9 weeks with either 100 μ g of the stable IgMk GW-23B7 or the derived TWF9 IgG2ak $A\beta$ ComAbs in 100 μ L of sterile saline or with 100 μ L of vehicle alone. Other groups of young 3xTg were inoculated with several tailored made mutations of the original pBri; whereas groups of 17 months old 3xTg were inoculated with the highly polymerized original pBri. The pBri immunizations and the $A\beta$ ComAbs were repeated in aged 16 month old SwDI animals prone to develop cerebral amyloid angiopathy due to the nature of the model, exacerbated by eventual reaction to $A\beta$ amyloid epitopes existing in vessels of the brain. All animals were subjected to radial arm maze, locomotor tests or Barnes maze after the treatment and before sacrifice. Histochemical and biochemical analysis were performed on brains from treated and control animals. **Results:** No adverse reactions were demonstrated during any one of

the different treatments. Old animals inoculated with the pBri produced a fare anti- β -sheet response; however, lower than in young animals. There was a significant cognitive rescue compared to controls and a significant reduction of both $A\beta$ and tau oligomers. The mutated peptides were not as efficient to elicit anti- β -sheet polyclonal response but still produce a significant amelioration on cognitive decline close to the results obtained by the original pBri. All SwDI animals either pBri immunized or $A\beta$ ComAbs infused –stable IgMk or IgG2ak- did not show any signs of vascular complication. In all cases the main biochemical improvement was the significant decrease on the number of oligomers of both $A\beta$ and tau as assessed by specific blots of solubilized brain extractions, ELISAs and MSD measurements. Immunohistochemically the extracellular $A\beta$ in plaques was significantly decreased whereas the intracellular PHF-tau remained fairly the same. **Conclusions:** The development of a specific antibody response –polyclonal or monoclonal- to strictly the secondary structure of a protein or peptide frozen in a stable β -sheet state is successfully achieved by the immunization with a highly polymerized, β -sheet only, immunogen with no other visible epitope. That specific response is completely independent of the primary structure of pathological conformers; thus, it interferes only with oligomeric pathologic conformers that show the dominant β -sheet secondary structure. Either treatment can produce, in various degrees, amelioration of AD pathology or evident cognitive rescue depending on the time of start of treatment. The mechanism is likely related to reductions of the levels of soluble oligomeric forms of $A\beta$ and Tau; the species most closely linked to cognitive deficits in AD patients and the prion-like propagation. These results are extremely encouraging for the further testing of potential combinations of immunizations and $A\beta$ ComAbs in clinical trials with disease modifying potential and minimal risk of autoimmune complications.

Theme: New therapies and clinical trials

LBP59: TRIPLE THERAPY WITH SUVN-502, A 5-HT6 ANTAGONIST, DONEPEZIL AND MEMANTINE IN MODERATE ALZHEIMER'S DISEASE: BASELINE PATIENT CHARACTERISTICS IN PHASE-2A STUDY. Alireza Atri^{1,2}, Jeffrey L. Cummings³, John Ieni⁴, Venkat Jasti⁴, Ramakrishna Nirogi⁴ ((1) *Banner Sun Health Research Institute/Banner Health, Sun City, AZ, USA*; (2) *Center for Brain/Mind medicine, Department of Neurology, Brigham and Women's Hospital and Harvard Medical School, Boston, MA, USA*; (3) *Cleveland Clinic, Las Vegas, NV, USA*; (4) *Discovery Research, Suven Life Sciences, Hyderabad, India*)

Introduction: There is an urgent need for improved treatment options for patients with Alzheimer's disease (AD) dementia. Approved anti-AD treatments include cholinesterase inhibitors (donepezil, rivastigmine, galantamine) and the NMDA receptor antagonist memantine which, taken as monotherapy or in dual combination, provide modest efficacy but can have dose limiting side effects. SUVN-502, a promising 5-HT6 receptor antagonist, is under development as a novel approach in the symptomatic treatment of AD dementia: triple therapy with SUVN-502 added to background treatment with donepezil and memantine. In preclinical studies, SUVN-502 has demonstrated excellent ADME properties; promising procognitive effects; robust psychophysiological and biochemical signals; and a good safety profile. In animal models assessing behavior, neurochemistry and electrophysiology,

SUVN-502 + donepezil + memantine triple combination demonstrated superior procognitive effects (object recognition task), acetylcholine modulation (microdialysis) and theta modulation (electrophysiology) compared to donepezil + memantine dual combination. Long-term animal toxicology studies with SUVN-502, donepezil, and memantine did not identify any significant toxicity risk signal; they also suggested a broad exposure safety margin. Finally, in healthy younger and older adult human subjects, SUVN-502 was well-tolerated following single or multiple oral administrations. **Objectives:** To assess the baseline patient characteristics of the SUVN-502 + donepezil + memantine phase-2a AD triple therapy study population (Clinical Trials.gov identifier NCT 02580305). **Methods:** Triple therapy with SUVN-502 added to background dual combination treatment with donepezil and memantine is currently under evaluation in a Phase-2a proof-of-concept, 26-week, randomized, double-blind, placebo-controlled, multicenter, parallel groups study conducted in the United States. This Phase-2a study evaluates the efficacy and safety of treatment with SUVN-502 compared to placebo in subjects with moderate AD dementia (MMSE score of 12 to 20) taking stable doses of background donepezil and memantine dual combination. The study involves a 2-to-4 week screening period, followed by a 26 week double-blind treatment period followed by a 4 week placebo washout. 537 subjects, age 50-85 years, will receive double-blind oral administration of one of three treatments once daily: SUVN-502 (50 mg), SUVN-502 (100 mg), or placebo in a 1:1:1 ratio (N=179 per group). Throughout the study, all subjects continue to receive background donepezil and memantine therapy. The study primary efficacy endpoint is the Alzheimer's Disease Assessment scale for Cognition (ADAS-Cog 11). Exploratory secondary endpoints include the Clinical Rating scale - sum of boxes score (CDR-sb), change in the Alzheimer's Disease Co-operative study - Activities of Daily Living scale (ADCS-ADL), the Neuropsychiatric Inventory (NPI), the Cornell scale for Depression & Dementia (C-SDD) and change in Mini-Mental State Examination (MMSE). The study was powered to detect a 2-point drug-placebo difference on the ADAS-Cog 11 at the Week-26 endpoint with power of 0.8 for a two-sided $p=0.05$, and assuming an ADAS-Cog 11 SD of 6 points and withdrawal of 20% or less. Subjects who complete the 30-week study treatment period may opt to continue treatment with SUVN-502 via an expanded access program (Clinical Trials.gov identifier NCT 03564964). **Results:** The real-time baseline patient characteristics of the enrolled study population (expected to be fully- or near fully-, enrolled) will be analyzed using customary summary statistics and comparisons. **Conclusions:** SUVN-502 is a promising, pure, 5-HT₆ receptor antagonist under development for the treatment of AD via a novel triple combination treatment approach. The ongoing phase-2a proof-of-concept trial evaluates the efficacy and safety of SUVN-502 added to background stable donepezil and memantine dual combination therapy in subjects with moderate AD dementia. Here, baseline characteristics of the Phase-2a clinical trial are reported; top-line efficacy results from the study are expected in 2019.

LBP60: CLINICAL POLYSOMNOGRAPHY TRIAL OF SUVOREXANT FOR TREATING INSOMNIA IN ALZHEIMER'S DISEASE: TRIAL DESIGN AND BASELINE CHARACTERISTICS OF PARTICIPANTS. W.J. Herring¹, P. Ceesay¹, E. Snyder¹, D. Bliwise², K. Budd¹, J. Hutzelmann¹, J. Stevens¹, D. Michelson¹ ((1) Merck & Co. Inc., Kenilworth, NJ, USA; (2) Emory University School of Medicine, Atlanta, GA, USA)

Background: Sleep disturbance and insomnia are common in patients with Alzheimer's disease but evidence for the efficacy of sleep medications in this population is limited, with few randomized controlled trials. Furthermore, potential worsening of cognitive impairment/next-day function is a concern. Suvorexant, a first-in-class orexin receptor antagonist that enables sleep to occur via competitive antagonism of wake-promoting orexins, was recently approved for treating elderly and non-elderly adults with insomnia. Its clinical profile may help to address an important unmet medical need in patients with Alzheimer's disease who have insomnia. **Objective:** To evaluate suvorexant for the treatment of insomnia in patients with Alzheimer's disease using gold-standard sleep laboratory polysomnography (PSG) assessments. **Methods:** This randomized, placebo-controlled trial consisted of a screening period followed by a double-blind 4-week treatment period (clinicalTrials.gov NCT02750306). Participants were required to meet diagnostic criteria for both Alzheimer's disease and insomnia and have a qualified trial partner. Eligible participants were randomized to suvorexant 10 mg (could be increased to 20 mg) or placebo. Assessments included overnight sleep laboratory PSG visits, an electronic sleep diary (completed by the trial partner), an activity/sleep watch (worn by the patient), and exploratory measures of cognition and neuropsychiatric behavior. The primary hypothesis is that suvorexant is superior to placebo in improving PSG-derived total sleep time (TST) at Week-4. The planned sample size of 260 randomized participants/117 evaluable participants per treatment group has approximately 80% power to detect a 25-minute difference in change-from-baseline in TST between treatment groups (standard effect size of 0.4). **Results:** Enrollment of the trial started in May 2016 and completed in September 2018. Results are anticipated in 2019. A total of 285 participants were randomized from 35 sites in 8 countries worldwide, with 66% recruited from the US, 24% from Peru, 9% from Europe, and 1% from other countries. 79% of participants were enrolled in the mild dementia (MMSE 21-26) strata, and 21% were enrolled in the moderate dementia (MMSE 12-20) strata. Preliminary baseline demographic data include the following: 65% were women, the mean (SD) age was 69 (9) years, and 58% were white. **Conclusion:** This is the largest randomized controlled trial of the effects of a sleep medication on PSG sleep measures undertaken in an Alzheimer's disease population. Results from the trial will help establish the efficacy and safety of suvorexant for treating insomnia in Alzheimer's disease.

LB61: NEUROPROTECTIVE EFFECT OF A NEW PHOTOBIO-MODULATION TECHNIQUE AGAINST AMYLOID A β 25-35 PEPTIDE INDUCED TOXICITY IN MICE MIGHT SUPPORT A NOVEL HYPOTHESIS FOR THERAPEUTIC APPROACH OF ALZHEIMER'S DISEASE.

Guillaume J. Blivet¹, Laura Auboyer¹, Johann Meunier², François J. Roman², Jacques Touchon^{3,4} ((1) REGENLIFE SAS, Montpellier, France; (2) Amylgen SAS, Montferrier-sur-Lez, France; (3) INSERM U1061, Montpellier, France, 4Neurology Department, University of Montpellier, France)

Background: Alzheimer's Disease (AD), the main cause of dementia, has yet no identified treatment able to slow or stop its progression. Photobiomodulation (PBM), a biophotonic approach, has been used in the last decade with encouraging results in animal studies in this context. We present the results obtained with the application of an innovating device RGN500 combining photonic and magnetic emissions on the neurotoxic effects produced by A β 25-35 (A β 25-35) oligomeric peptide central injection (intracerebro-ventricularly) in mice. **Methods:** RGN500 device was made with a near infrared (NIR) InAlGaAs laser (850nm) combined with a NIR LED (850nm) and a red LED (625nm). This photonic device is surrounded with a ring-shaped magnet creating a static magnetic field of 200mT. The photonic emissions were pulsed at a 10Hz frequency. Treatment was applied once a day for 7 days following the injection of A β 25-35 peptide for a duration of 2.5, 5, 10 or 20 min. Photonic emitters were applied on the head, on the center of abdomen or both. **Results:** Our results clearly indicate that RGN500 treatment produced a neuroprotective effect in the A β 25-35 mouse model, when the light beam was applied both on the head and on the abdomen and not when only the head or abdomen were irradiated. This protective effect was dependent on the time of application and a total reversal of deficits was obtained for 20 min of daily application. Protection against A β 25-35 neurotoxicity was demonstrated both by memory restoration in the two tests that were investigated, Y-maze and STPA, and on the normalization of key markers of AD (A β 1-42, pTau), oxidative stress (lipid peroxidation), and cell integrity (Bax/Bcl2). Neuroinflammation was highly activated following A β 25-35 injection and RGN500 treatment was able to fully reverse the elevation of TNF α as well as GFAP. In agreement with these biochemical measurements, immuno-histochemical observation of hippocampal slices showed that the activation of astrocytes and microglial cells was fully reversed by daily applications of RGN500. **Conclusion:** RGN500 displays a promising therapeutic efficacy on several key aspects suggesting the pertinence of this innovating technology for a therapeutic approach of AD. It appears that combination treatments engaging not only one but several targets are currently needed if we want to treat this complex neurodegenerative disorder.

LBP62: INTEREST OF REGENLIFE RGN530 PHOTOBIO-MODULATION MEDICAL DEVICE FOR THE TREATMENT OF ALZHEIMER'S DISEASE: A DOUBLE-BLIND, RANDOMIZED SHAM-CONTROLLED TRIAL TO EVALUATE THE SAFETY AND EFFICACY.

Audrey Gabelle^{1,2}, Thibault Mura^{2,3}, Karim Bennys^{1,2}, Sophie Navucet^{1,2}, Martine Flores^{1,2}, Laura Auboyer⁴, Guillaume J. Blivet⁴, Jacques Touchon^{1,2} ((1) Memory Research and Resources Center of Montpellier, Department of Neurology, Montpellier University Hospital, France; (2) MUSE University, Inserm U1061, Montpellier, France; (3) Department of Epidemiologic and Clinical Research, La Colombière Hospital, Montpellier, France; (4) REGENLIFE SAS, Montpellier, France)

Background: No curative treatment is available for Alzheimer's disease (AD), however new innovative therapeutics emerged based on a medical device. REGENLIFE RGN530 is a photobiomodulation medical device, consisting in a modular helmet and abdominal panel, composed of near-infrared low-level lasers (LLLT), near-infrared and red LEDs as well as a static magnetic field. Preclinical results, obtained in a pathological model, via injection of amyloid- β 25-35 peptide in male Swiss mice, revealed memory restoration and normalization of A β 42, pTau, lipid peroxidation, Bax/Bcl2 ratio and neuroinflammation markers in treated versus sham group (Blivet et al., *Alzheimers Dement* (NY), 2018). **Objective:** To assess the safety and efficacy of RGN530 in mild to moderate AD patients, and in particular on the composite cognitive score. **Methods:** A monocentric double-blind, randomized, sham-controlled clinical trial has been initiated at the Montpellier University Hospital (Memory Research Center of Montpellier). 64 patients with NIA diagnosis criteria of AD will be included and randomized in the RGN530 group (n=32) and the sham group (n=32). Five sessions of 25min per week for 8 weeks will be performed. The primary outcome is the difference on the cognitive composite score at baseline and after 3 months. Clinical, neuropsychological, CSF biomarkers, synaptic and inflammatory biomarkers, MRI and PET-FDG brain imaging will be available to determine the impact of RGN530 on AD biomarkers. The safety and tolerability will also be evaluated. **Conclusion:** The design of this innovative strategy for AD treatment will be detailed. The advantages and limits of such approach will be discussed.